



NORDfire FDMA Fire Damper

Square dampers from 180×180 mm to 1600×1000 mm

CE certified acc. to EN 15650

External Casing leakage class C, Internal leakage class 2 acc. to EN 1751

Damper actuating mechanical, or electrical

Fire resistance up to EIS 120

General information

1. Description

Fire dampers are shutters in ducts of air-conditioning devices that prevent spreading the fire and combustion products from one fire segment to the other one by means of closing the duct in the points of fire separating constructions.

Dampers blade automatically closes air duct using a shutting spring or an actuating mechanism back spring. The shutting spring is started by releasing an initiation lever. The impulse for releasing the lever can be either a manual one, a thermal one or an electromagnetic one. The back spring of the actuating mechanism is started when the thermoelectrical starting mechanism BAT is activated, when a reset button on BAT is pushed or when a power supply of the actuating mechanism is stopped.

The damper is sealed with a silicon packing against smoke penetration after closing the blade. At the same time, the damper blade is bedded in a material which enlarges its capacity and air proofs the air duct.

Dampers have two inspection holes.

Fig. 1 FDMA with actuating mechanism



Fig. 2 FDMA with mechanical control



1.1 Damper characteristics

- CE certified acc. to EN 15650
- Tested in accordance with EN 1366-2
- Classified acc. to EN 13501-3+A1
- Fire resistance EIS 120, EIS 90
- External Casing leakage class C, Internal leakage class 2 acc. to EN 1751
- Cycling test in class C 10000 acc. to EN 15650
- Corrosion resistant acc. to EN 15650
- ES Certificate of conformity No. 1391-CPR-2016/0158
- Declaration of Performance No. PM/FDMA/01/20/1
- Hygienic assessment of fire dampers - Report No. 1.6/pos/19/19b

1.2 Working conditions

Right damper function is secured under the following conditions:

- a) Maximum air circulation speed: 12 m/s
Maximum pressure difference: 1200 Pa
- b) The air circulation in the whole damper section must be secured as steady on whole surface.

Operation of the dampers does not depend on the direction of air circulation. The dampers can be located in an arbitrary position.

Dampers are suitable for systems without abrasive, chemical and adhesive particles.

Dampers are designed for macroclimatic areas with mild climate according to EN 60 721-3-3.

Temperature in the place of installation is permitted to range from -30°C to +50°C.

2. Design

2.1 Design with mechanical control

Design .01

Design with mechanical control with a thermal protective fuse which actuates the shutting device after the nominal start temperature 72°C has been reached. Automatic initiation of the shutting device is not activated if the temperature does not exceed 70°C. In case that other start temperatures are required, thermal fuses with nominal start temperature +104°C or +147°C can be supplied (this requirement must be specified in the order).

Fig. 3 Design .01 - design with mechanical control

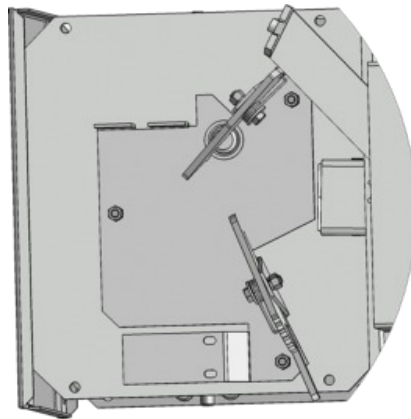

Design .11

Design .01 with mechanical control can be complemented with a limit switch signalling of the damper blade position "CLOSED"

Fig. 4 Design .11 - design with mechanical control and limit switch "CLOSE"

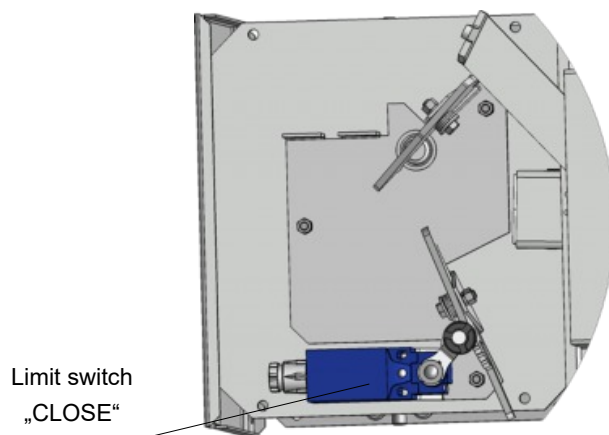
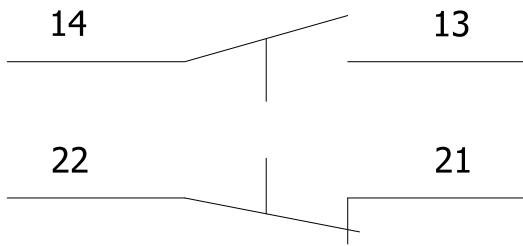

Fig. 5 Limit switch XCKN211BG-11



Nominal voltage and max. current	AC 240 V; 3 A DC 250 V; 0,1 A
Degree of protection	IP 65
Ambient temperature	-15°C ... +70°C

Design .80

Design .11 can be complemented with a terminal switch signalling of the damper blade position "OPEN"

Fig. 6 Design .80 - design with mechanical control and limit switch "OPEN", "CLOSE"

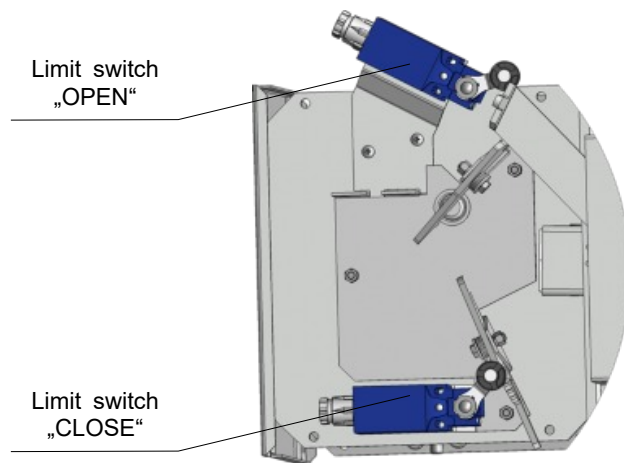

2.2 Design with actuating mechanism

Design .40, .50

The damper are equipped by Belimo actuators with spring return and thermoelectric activation device of BFL, BFN or BF depending on the damper size (further mentioned as „actuators“).

After being connected to power supply AC/DC 24V or 230V, the actuating mechanism displaces the damper blade into operation position "OPEN" and at the same time it pre-stretches its back spring. When the actuating mechanism is under voltage, the damper blade is in the position "OPEN" and the back spring is pre-stretched. Time needed for full opening of the flap blade from the position "CLOSED" to the position "OPEN" is maximum 120 sec. If the actuating power supply is cut off (due to loss of supply voltage, or pushing the reset button on the thermoelectrical starting mechanism BAT), the back spring displaces the damper blade into the breakdown position "CLOSED". The time of displacing the blade from the position "OPEN" to the position "CLOSED" takes maximum 20 sec. In case that the power supply is restored again (the blade can be in any position), the actuating mechanism starts to re-displace the damper blade into the position "OPEN".

A thermoelectrical starting mechanism BAT, which contains two thermal fuses Tf1 and Tf2, is a part of the actuating mechanism. These fuses are activated when temperature +72°C has been exceeded (the fuse Tf1 when the temperature around the damper and the fuses Tf2 when the temperature inside the air-conditioning piping has been exceeded). After the thermal fuse Tf1 or Tf2 has been activated, the power supply is permanently and irreversibly cut off and the actuating mechanism, by means of the pre-stretched spring, displaces the damper blade into the breakdown position "CLOSED".

Signalisation of damper blade position "OPEN" a "CLOSE" is provided by two limit switches.

Fig. 7 Design .40, .50

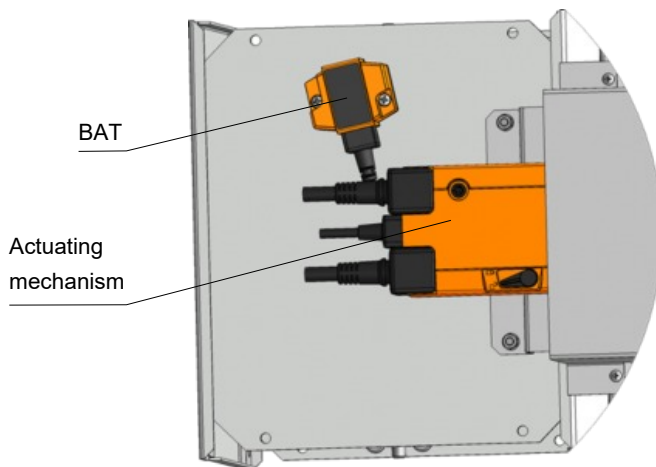

Fig. 8 Actuating mechanism BELIMO BFL (BFN) 230-T

AC230 V

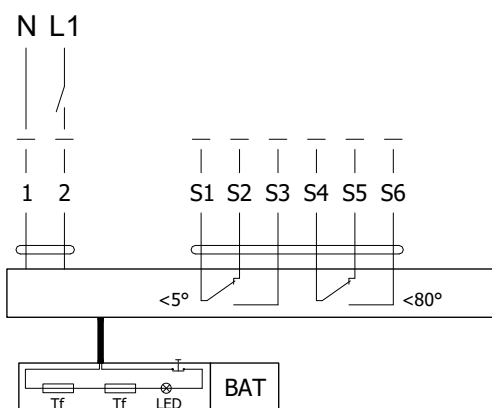
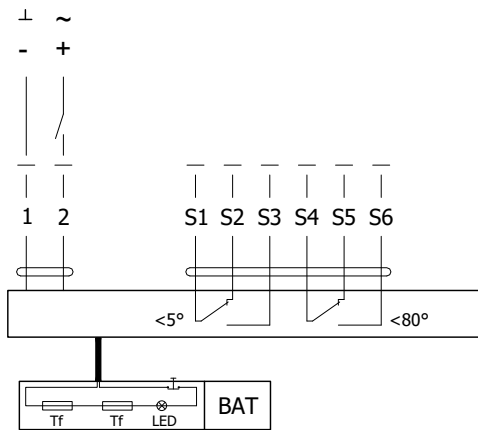

Fig. 9 Actuating mechanism BELIMO BFL (BFN) 24-T(-ST)

AC/DC 24



Tab 2.2.1. Actuating mechanism BELIMO BFL 24-T(-ST), BFN 24-T(-ST), BFL 230-T a BFN 230-T

Actuating mechanism BELIMO	BFL, BFN 230-T	BFL, BFN 24-T(-ST)
Nominal voltage	AC 230 V 50/60 Hz	AC 24 V 50/60 Hz DC 24 V
Power consumption		
- motoring	3,5/5 W	2,5/4 W
- holding	1,1/2,1 W	0,8/1,4 W
Dimensioning	6,5/10 VA (I _{max} 4 A @ 5 ms)	4/6 VA (I _{max} 8,3 A @ 5 ms)
Protection class	II	III
Degree of protection		IP 54
Running time		
- motor		<60 s
- spring return		~ 20 s
Ambient temperature		
- normal duty		- 30°C ... +55°C
- safety duty		The safe position will be attained up to max. +75°C
- non-operating temperature		- 40°C ... +55°C
Connecting		
- motor	cable 1 m, 2 x 0,75 mm ² (BFL/BFN 24-T(-ST)) with 3-pin plug-in connectors	
- auxiliary switch	cable 1 m, 6 x 0,75 mm ² (BFL/BFN 24-T(-ST)) with 6-pin plug-in connectors	
Thermal trips	duct outside temperature +72°C duct inside temperature +72°C	

Fig. 10 Actuating mechanism BELIMO BFM 230-TN, BF 24-TN (-ST)

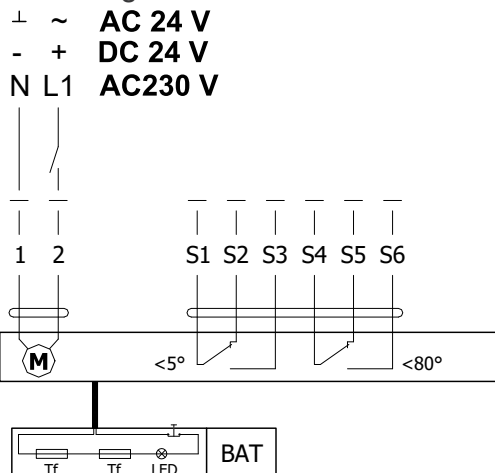

Tab 2.2.2. Actuating mechanism BELIMO BF 24-TN(-ST), BF 230-TN

Actuating mechanism BELIMO	BF 24-TN(-ST)	BF 230-TN
Nominal voltage	AC 24 V 50/60 Hz DC 24 V	AC 230 V 50/60 Hz
Power consumption		
- motoring	7 W	8 W
- holding	2 W	3 W
Dimensioning	10 VA (I _{max} 8,3 A @ 5 ms)	12,5 VA (I _{max} 500 mA @ 5 ms)
Protection class	III	II
Degree of protection	IP 54	
Running time		
- motor	120 sec	
- spring return	~ 16 sec	
Ambient temperature		
- normal duty	- 30°C ... +50°C	
- safety duty	The safe position will be attained up to max. +75°C	
- non-operating temperature	- 40°C ... +50°C	
Connecting:		
- motor	cable 1 m, 2 x 0,75 mm ²	
- auxiliary switch	cable 1 m, 6 x 0,75 mm ²	
	(BF 24-T-ST) with plug-in connectors	
Thermal trips	Tf1: duct outside temperature Duct +72°C Tf2/Tf3: duct inside temperature Duct +72°C	

3. Dimensions, weighs and effective area

3.1 Dimensions

Fig. 11 Design manual and thermal

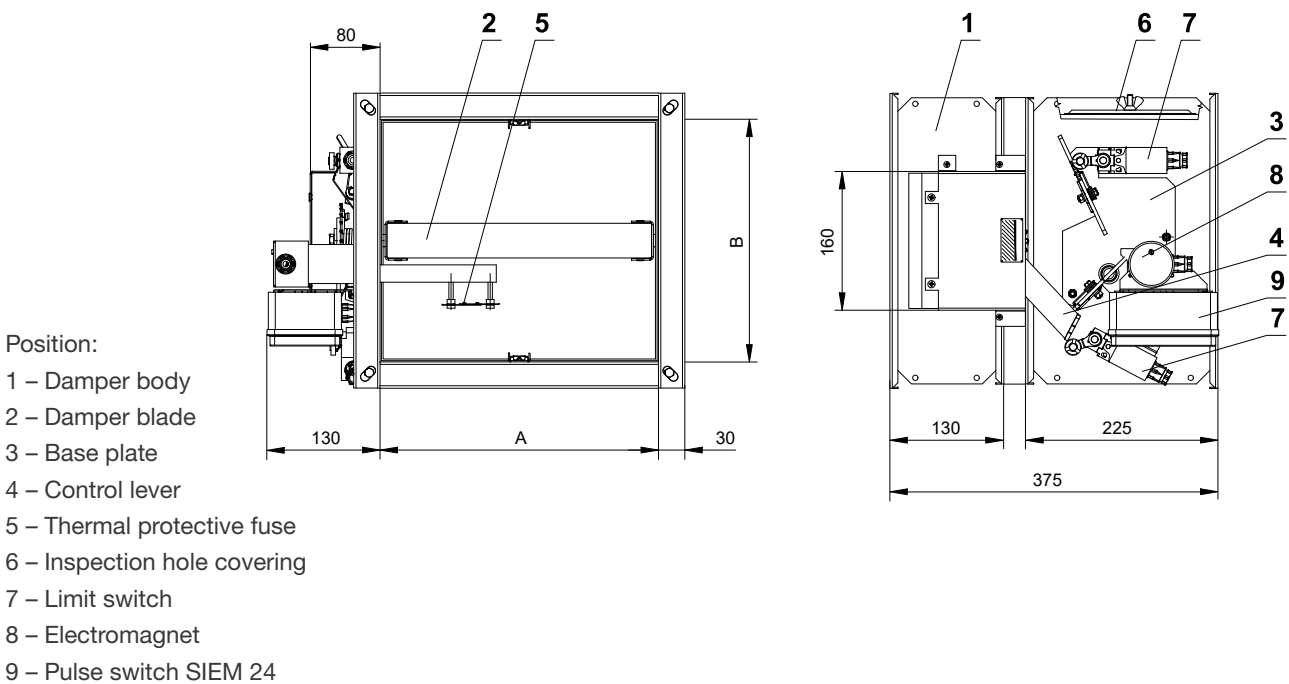
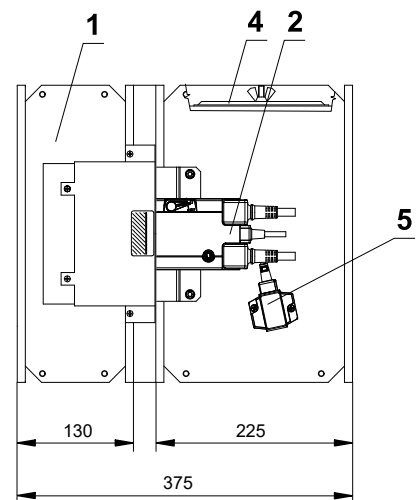
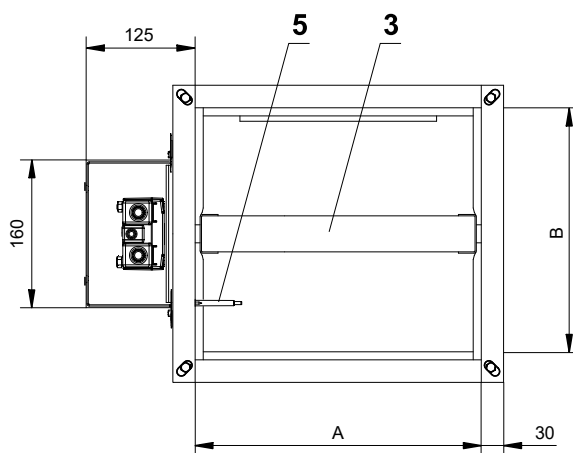

Fig. 12 Design with actuating mechanism



Position:

- 1 – Damper body
- 2 – Actuating mechanism
- 3 – Damper blade
- 4 – Inspection hole covering
- 5 – BAT thermoelectrical starting mechanism

Fig. 13 Design with actuating mechanism (ZONE 1,2)

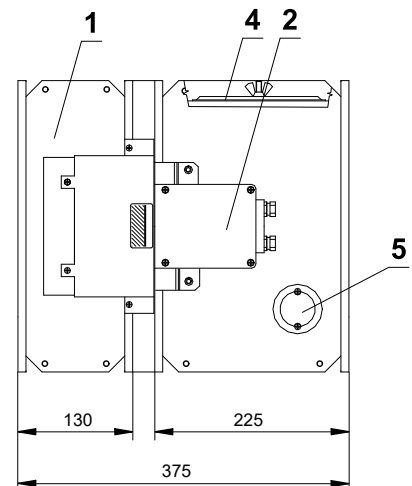
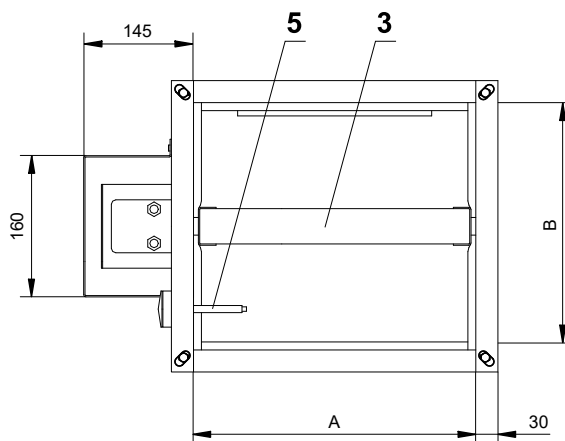

Position:

- 1 – Damper body
- 2 – Actuating mechanism
- 3 – Damper blade
- 4 – Inspection hole covering
- 5 – BAT thermoelectrical starting mechanism

3.2 Dimensions, weights and effective area

Tab 3.2.1. Dimensions, weights and effective area

AxB (mm)	a (mm)	c (mm)	Weight		Effect. area Sef (m ²)	Mehh. kontr.
			Design			
			mech (kg)	servo (kg)		
180 x 180	-	-	9,0	10,7	0,0192	BFL
x 200	-	-	9,4	11,1	0,0224	BFL
x 225	-	-	9,9	11,6	0,0264	BFL
x 250	-	5	10,5	12,2	0,0304	BFL
x 280	-	20	11,1	12,8	0,0352	BFL
x 300	-	30	11,5	13,2	0,0384	BFL
x 315	-	37	11,8	13,5	0,0408	BFL
x 355	-	57	12,7	14,4	0,0472	BFL
x 400	-	80	13,6	15,3	0,0544	BFL
x 450	-	105	14,6	17,6	0,0624	BFL
x 500	-	130	15,7	18,7	0,0704	BFL
x 550	10	155	16,7	19,7	0,0784	BFL
x 560	15	160	16,9	19,9	0,0800	BFL
x 600	35	180	17,8	20,8	0,0864	BFL
x 630	50	195	18,4	21,4	0,0912	BFL
x 650	60	205	18,8	21,8	0,0944	BFL
x 700	85	230	19,9	22,9	0,1024	BFN
x 710	90	235	20,1	23,1	0,1040	BFN
x 750	110	255	20,9	23,9	0,1104	BFN
x 800	135	280	22,0	25,0	0,1184	BFN
200 x 180	-	-	9,4	11,1	0,0216	BFL
x 200	-	-	9,8	11,5	0,0252	BFL
x 225	-	-	10,3	12,0	0,0297	BFL
x 250	-	5	10,9	12,6	0,0396	BFL
x 280	-	20	11,5	13,2	0,0342	BFL
x 300	-	30	12,0	13,7	0,0432	BFL
x 315	-	37	12,3	14,0	0,0459	BFL
x 355	-	57	13,1	14,8	0,0531	BFL
x 400	-	80	14,1	15,8	0,0612	BFL
x 450	-	105	15,2	18,2	0,0702	BFL
x 500	-	130	16,3	19,3	0,0792	BFL
x 550	10	155	17,4	20,4	0,0882	BFL
x 560	15	160	17,6	20,6	0,0900	BFL
x 600	35	180	18,4	21,4	0,0972	BFL
x 630	50	195	19,1	22,1	0,1026	BFL
x 650	60	205	19,5	22,5	0,1062	BFL
x 700	85	230	20,6	23,6	0,1152	BFN
x 710	90	235	20,8	23,8	0,1170	BFN
x 750	110	255	21,7	24,7	0,1242	BFN
x 800	135	280	22,8	25,8	0,1332	BFN
x 900	185	330	24,9	27,9	0,1512	BFN
x1000	235	380	27,1	30,1	0,1692	BFN
225 x 180	-	-	9,8	11,5	0,0246	BFL
x 200	-	-	10,3	12,0	0,0287	BFL
x 225	-	-	10,8	12,5	0,0338	BFL
x 250	-	5	11,4	13,1	0,0390	BFL
x 280	-	20	12,1	13,8	0,0451	BFL
x 300	-	30	12,5	14,2	0,0492	BFL
x 315	-	37	12,9	14,6	0,0523	BFL
x 355	-	57	13,8	15,5	0,0605	BFL
x 400	-	80	14,8	16,5	0,0697	BFL
225 x 450	-	105	15,9	18,9	0,0800	BFL
x 500	-	130	17,0	20,0	0,0902	BFL
x 550	10	155	18,2	21,2	0,1005	BFL
x 560	15	160	18,4	21,4	0,1025	BFL
x 600	35	180	19,3	22,3	0,1107	BFL
x 630	50	195	20,0	23,0	0,1169	BFN
x 650	60	205	20,4	23,4	0,1210	BFN
x 700	85	230	21,5	24,5	0,1312	BFN
x 710	90	235	21,8	24,8	0,1333	BFN
x 750	110	255	22,7	25,7	0,1415	BFN
x 800	135	280	23,8	26,8	0,1517	BFN
x 900	185	330	26,0	29,0	0,1722	BFN
x1000	235	380	28,3	31,3	0,1927	BF
250 x 180	-	-	10,3	12,0	0,0276	BFL
x 200	-	-	10,7	12,4	0,0322	BFL
x 225	-	-	11,3	13,0	0,0380	BFL
x 250	-	5	11,9	13,6	0,0437	BFL
x 280	-	20	12,6	14,3	0,0506	BFL
x 300	-	30	13,1	14,8	0,0552	BFL
x 315	-	37	13,4	15,1	0,0587	BFL
x 355	-	57	14,4	16,1	0,0679	BFL
x 400	-	80	15,4	17,1	0,0782	BFL
x 450	-	105	16,6	19,6	0,0897	BFL
x 500	-	130	17,8	20,8	0,1012	BFL
x 550	10	155	18,9	21,9	0,1127	BFL
x 560	15	160	19,2	22,2	0,1150	BFL
x 600	35	180	20,1	23,1	0,1242	BFN
x 630	50	195	20,8	23,8	0,1311	BFN
x 650	60	205	21,3	24,3	0,1357	BFN
x 700	85	230	22,5	25,5	0,1472	BFN
x 710	90	235	22,7	25,7	0,1495	BFN
x 750	110	255	23,6	26,6	0,1587	BFN
x 800	135	280	24,8	27,8	0,1702	BFN
x 900	185	330	27,2	30,2	0,1932	BFN
x1000	235	380	29,5	32,5	0,2162	BF
280 x 180	-	-	10,8	12,5	0,0312	BFL
x 200	-	-	11,3	13,0	0,0364	BFL
x 225	-	-	11,9	13,6	0,0429	BFL
x 250	-	5	12,5	14,2	0,0494	BFL
x 280	-	20	13,3	15,0	0,0572	BFL
x 300	-	30	13,8	15,5	0,0624	BFL
x 315	-	37	14,1	15,8	0,0663	BFL
x 355	-	57	15,1	16,8	0,0767	BFL
x 400	-	80	16,2	17,9	0,0884	BFL
x 450	-	105	17,4	20,4	0,1014	BFL
x 500	-	130	18,7	21,7	0,1144	BFL
x 550	10	155	19,9	22,9	0,1274	BFL
x 560	15	160	20,1	23,1	0,1300	BFN
x 600	35	180	21,1	24,1	0,1404	BFN
x 630	50	195	21,9	24,9	0,1482	BFN
x 650	60	205	22,4	25,4	0,1534	BFN

AxB (mm)	a (mm)	c (mm)	Weight		Effect. area Sef (m ²)	Mehh. kontr.
			Design			
			mech (kg)	servo (kg)		
280 x 700	85	230	23,6	26,6	0,1664	BFN
x 710	90	235	23,8	26,8	0,1690	BFN
x 750	110	255	24,8	27,8	0,1794	BFN
x 800	135	280	26,0	29,0	0,1924	BFN
x 900	185	330	28,5	31,5	0,2184	BF
x1000	235	380	30,9	33,9	0,2444	BF
300 x 180	-	-	11,2	12,9	0,0336	BFL
x 200	-	-	11,7	13,4	0,0392	BFL
x 225	-	-	12,3	14,0	0,0462	BFL
x 250	-	5	13,0	14,7	0,0532	BFL
x 280	-	20	13,7	15,4	0,0616	BFL
x 300	-	30	14,2	15,9	0,0672	BFL
x 315	-	37	14,6	16,3	0,0714	BFL
x 355	-	57	15,6	17,3	0,0826	BFL
x 400	-	80	16,8	18,5	0,0952	BFL
x 450	-	105	18,0	21,0	0,1092	BFL
x 500	-	130	19,3	22,3	0,1232	BFL
x 550	10	155	20,5	23,5	0,1372	BFN
x 560	15	160	20,8	23,8	0,1400	BFN
x 600	35	180	21,8	24,8	0,1512	BFN
x 630	50	195	22,6	25,6	0,1596	BFN
x 650	60	205	23,1	26,1	0,1652	BFN
x 700	85	230	24,3	27,3	0,1792	BFN
x 710	90	235	24,6	27,6	0,1820	BFN
x 750	110	255	25,6	28,6	0,1932	BFN
x 800	135	280	26,8	29,8	0,2072	BFN
x 900	185	330	29,4	32,4	0,2352	BF
x1000	235	380	31,9	34,9	0,2632	BF
315 x 180	-	-	11,5	13,2	0,0354	BFL
x 200	-	-	12,0	13,7	0,0413	BFL
x 225	-	-	12,6	14,3	0,0487	BFL
x 250	-	5	13,3	15,0	0,0561	BFL
x 280	-	20	14,1	15,8	0,0649	BFL
x 300	-	30	14,6	16,3	0,0708	BFL
x 315	-	37	15,0	16,7	0,0752	BFL
x 355	-	57	16,0	17,7	0,0870	BFL
x 400	-	80	17,1	18,8	0,1003	BFL
x 450	-	105	18,4	21,4	0,1151	BFL
x 500	-	130	19,7	22,7	0,1298	BFL
x 550	10	155	21,0	24,0	0,1446	BFN
x 560	15	160	21,3	24,3	0,1475	BFN
x 600	35	180	22,3	25,3	0,1593	BFN
x 630	50	195	23,1	26,1	0,1682	BFN
x 650	60	205	23,6	26,6	0,1741	BFN
x 700	85	230	24,9	27,9	0,1888	BFN
x 710	90	235	25,1	28,1	0,1918	BFN
x 750	110	255	26,2	29,2	0,2036	BFN
x 800	135	280	27,5	30,5	0,2183	BFN
x 900	185	330	30,0	33,0	0,2478	BF
x1000	235	380	32,6	35,6	0,2773	BF
355 x 180	-	-	12,2	13,9	0,0402	BFL
x 200	-	-	12,8	14,5	0,0469	BFL
x 225	-	-	13,4	15,1	0,0553	BFL

AxB (mm)	a (mm)	c (mm)	Weight		Effect. area Sef (m ²)	Mehh. kontr.
			Design			
			mech (kg)	servo (kg)		
355 x 250	-	5	14,1	15,8	0,0737	BFL
x 280	-	20	14,9	16,6	0,0637	BFL
x 300	-	30	15,5	17,2	0,0804	BFL
x 315	-	37	15,9	17,6	0,0854	BFL
x 355	-	57	17,0	18,7	0,0988	BFL
x 400	-	80	18,2	19,9	0,1139	BFL
x 450	-	105	19,6	22,6	0,1307	BFL
x 500	-	130	20,9	23,9	0,1474	BFN
x 550	10	155	22,3	25,3	0,1642	BFN
x 560	15	160	22,6	25,6	0,1675	BFN
x 600	35	180	23,6	26,6	0,1809	BFN
x 630	50	195	24,5	27,5	0,1910	BFN
x 650	60	205	25,0	28,0	0,1977	BFN
x 700	85	230	26,4	29,4	0,2144	BFN
x 710	90	235	26,6	29,6	0,2178	BFN
x 750	110	255	27,7	30,7	0,2312	BFN
x 800	135	280	29,1	32,1	0,2479	BF
x 900	185	330	31,8	34,8	0,2814	BF
x1000	235	380	34,5	37,5	0,3149	BF
400 x 180	-	-	13,0	14,7	0,0456	BFL
x 200	-	-	13,6	15,3	0,0532	BFL
x 225	-	-	14,3	16,0	0,0627	BFL
x 250	-	5	15,1	16,8	0,0722	BFL
x 280	-	20	15,9	17,6	0,0836	BFL
x 300	-	30	16,5	18,2	0,0912	BFL
x 315	-	37	16,9	18,6	0,0969	BFL
x 355	-	57	18,1	19,8	0,1121	BFL
x 400	-	80	19,4	21,1	0,1292	BFL
x 450	-	105	20,8	23,8	0,1482	BFL
x 500	-	130	22,3	25,3	0,1672	BFN
x 550	10	155	23,7	26,7	0,1862	BFN
x 560	15	160	24,0	27,0	0,1900	BFN
x 600	35	180	25,1	28,1	0,2052	BFN
x 630	50	195	26,0	29,0	0,2166	BFN
x 650	60	205	26,6	29,6	0,2242	BFN
x 700	85	230	28,0	31,0	0,2432	BFN
x 710	90	235	28,3	31,3	0,2470	BFN
x 750	110	255	29,5	32,5	0,2622	BF
x 800	135	280	30,9	33,9	0,2812	BF
x 900	185	330	33,8	36,8	0,3192	BF
x1000	235	380	36,7	39,7	0,3572	BF
450 x 180	-	-	14,0	15,7	0,0516	BFL
x 200	-	-	14,6	16,3	0,0602	BFL
x 225	-	-	15,3	17,0	0,0710	BFL
x 250	-	5	16,1	17,8	0,0817	BFL
x 280	-	20	17,0	18,7	0,0946	BFL
x 300	-	30	17,6	19,3	0,1032	BFL
x 315	-	37	18,1	19,8	0,1097	BFL
x 355	-	57	19,3	21,0	0,1269	BFL
x 400	-	80	20,7	22,4	0,1462	BFL
x 450	-	105	22,2	25,2	0,1677	BFN
x 500	-	130	23,8	26,8	0,1892	BFN
x 550	10	155	25,3	28,3	0,2107	BFN

AxB (mm)	a (mm)	c (mm)	Weight		Effect. area Sef (m ²)	Mehh. kontr.
			Design			
			mech (kg)	servo (kg)		
450 x 560	15	160	25,6	28,6	0,2150	BFN
x 600	35	180	26,8	29,8	0,2322	BFN
x 630	50	195	27,7	30,7	0,2451	BFN
x 650	60	205	28,4	31,4	0,2537	BFN
x 700	85	230	29,9	32,9	0,2752	BF
x 710	90	235	30,2	33,2	0,2795	BF
x 750	110	255	31,4	34,4	0,2967	BF
x 800	135	280	33,0	36,0	0,3182	BF
x 900	185	330	36,0	39,0	0,3612	BF
x1000	235	380	39,1	42,1	0,4042	BF
500 x 180	-	-	14,9	16,6	0,0576	BFL
x 200	-	-	15,5	17,2	0,0672	BFL
x 225	-	-	16,3	18,0	0,0792	BFL
x 250	-	5	17,1	18,8	0,0912	BFL
x 280	-	20	18,1	19,8	0,1056	BFL
x 300	-	30	18,8	20,5	0,1152	BFL
x 315	-	37	19,3	21,0	0,1224	BFL
x 355	-	57	20,6	22,3	0,1416	BFL
x 400	-	80	22,0	23,7	0,1632	BFL
x 450	-	105	23,6	26,6	0,1872	BFN
x 500	-	130	25,3	28,3	0,2112	BFN
x 550	10	155	26,9	29,9	0,2352	BFN
x 560	15	160	27,2	30,2	0,2400	BFN
x 600	35	180	28,5	31,5	0,2592	BFN
x 630	50	195	29,5	32,5	0,2736	BFN
x 650	60	205	30,1	33,1	0,2832	BF
x 700	85	230	31,7	34,7	0,3072	BF
x 710	90	235	32,1	35,1	0,3120	BF
x 750	110	255	33,4	36,4	0,3312	BF
x 800	135	280	35,0	38,0	0,3552	BF
x 900	185	330	38,2	41,2	0,4032	BF
x1000	235	380	41,5	44,5	0,4512	BF
550 x 180	-	-	15,8	17,5	0,0636	BFL
x 200	-	-	16,5	18,2	0,0742	BFL
x 225	-	-	17,3	19,0	0,0875	BFL
x 250	-	5	18,2	19,9	0,1007	BFL
x 280	-	20	19,2	20,9	0,1166	BFL
x 300	-	30	19,9	21,6	0,1272	BFL
x 315	-	37	20,4	22,1	0,1352	BFL
x 355	-	57	21,8	23,5	0,1564	BFL
x 400	-	80	23,3	25,0	0,1802	BFN
x 450	-	105	25,0	28,0	0,2067	BFN
x 500	-	130	26,8	29,8	0,2332	BFN
x 550	10	155	28,5	31,5	0,2597	BFN
x 560	15	160	28,8	31,8	0,2650	BFN
x 600	35	180	30,2	33,2	0,2862	BFN
x 630	50	195	31,2	34,2	0,3021	BF
x 650	60	205	31,9	34,9	0,3127	BF
x 700	85	230	33,6	36,6	0,3392	BF
x 710	90	235	33,9	36,9	0,3445	BF
x 750	110	255	35,3	38,3	0,3657	BF
x 800	135	280	37,0	40,0	0,3922	BF
x 900	185	330	40,4	43,4	0,4452	BF

AxB (mm)	a (mm)	c (mm)	Weight		Effect. area Sef (m ²)	Mehh. kontr.
			Design			
			mech (kg)	servo (kg)		
550x1000	235	380	43,9	46,9	0,4982	BF
560 x 180	-	-	16,0	17,7	0,0648	BFL
x 200	-	-	16,7	18,4	0,0756	BFL
x 225	-	-	17,5	19,2	0,0891	BFL
x 250	-	5	18,4	20,1	0,1026	BFL
x 280	-	20	19,4	21,1	0,1188	BFL
x 300	-	30	20,1	21,8	0,1296	BFL
x 315	-	37	20,7	22,4	0,1377	BFL
x 355	-	57	22,0	23,7	0,1593	BFL
x 400	-	80	23,6	25,3	0,1836	BFN
x 450	-	105	25,3	28,3	0,2106	BFN
x 500	-	130	27,1	30,1	0,2376	BFN
x 550	10	155	28,8	31,8	0,2646	BFN
x 560	15	160	29,1	32,1	0,2700	BFN
x 600	35	180	30,5	33,5	0,2916	BFN
x 630	50	195	31,6	34,6	0,3078	BF
x 650	60	205	32,2	35,2	0,3186	BF
x 700	85	230	34,0	37,0	0,3456	BF
x 710	90	235	34,3	37,3	0,3510	BF
x 750	110	255	35,7	38,7	0,3726	BF
x 800	135	280	37,4	40,4	0,3996	BF
x 900	185	330	40,9	43,9	0,4536	BF
x1000	235	380	44,4	47,4	0,5076	BF
600 x 180	-	-	16,7	19,7	0,0696	BFL
x 200	-	-	17,4	20,4	0,0812	BFL
x 225	-	-	18,3	21,3	0,0957	BFL
x 250	-	5	19,2	22,2	0,1102	BFL
x 280	-	20	20,3	23,3	0,1276	BFL
x 300	-	30	21,0	24,0	0,1392	BFL
x 315	-	37	21,6	24,6	0,1479	BFL
x 355	-	57	23,0	26,0	0,1711	BFL
x 400	-	80	24,6	27,6	0,1972	BFN
x 450	-	105	26,4	29,4	0,2262	BFN
x 500	-	130	28,3	31,3	0,2552	BFN
x 550	10	155	30,1	33,1	0,2842	BFN
x 560	15	160	30,4	33,4	0,2900	BFN
x 600	35	180	31,9	34,9	0,3132	BF
x 630	50	195	32,9	35,9	0,3306	BF
x 650	60	205	33,7	36,7	0,3422	BF
x 700	85	230	35,5	38,5	0,3712	BF
x 710	90	235	35,8	38,8	0,3770	BF
x 750	110	255	37,3	40,3	0,4002	BF
x 800	135	280	39,1	42,1	0,4292	BF
x 900	185	330	42,7	45,7	0,4872	BF
x1000	235	380	46,3	49,3	0,5452	BF
630 x 180	-	-	17,3	20,3	0,0732	BFL
x 200	-	-	18,0	21,0	0,0854	BFL
x 225	-	-	18,9	21,9	0,1007	BFL
x 250	-	5	19,9	22,9	0,1159	BFL
x 280	-	20	21,0	24,0	0,1342	BFL
x 300	-	30	21,7	24,7	0,1464	BFL
x 315	-	37	22,3	25,3	0,1556	BFL
x 355	-	57	23,8	26,8	0,1800	BFL

AxB (mm)	a (mm)	c (mm)	Weight		Effect. area Sef (m²)	Mehh. kontr.
			Design			
			mech (kg)	servo (kg)		
630 x 400	-	80	25,4	28,4	0,2074	BFN
x 450	-	105	27,3	30,3	0,2379	BFN
x 500	-	130	29,1	32,1	0,2684	BFN
x 550	10	155	31,0	34,0	0,2989	BFN
x 560	15	160	31,4	34,4	0,3050	BFN
x 600	35	180	32,9	35,9	0,3294	BF
x 630	50	195	34,0	37,0	0,3477	BF
x 650	60	205	34,7	37,7	0,3599	BF
x 700	85	230	36,6	39,6	0,3904	BF
x 710	90	235	36,9	39,9	0,3965	BF
x 750	110	255	38,4	41,4	0,4209	BF
x 800	135	280	40,3	43,3	0,4514	BF
x 900	185	330	44,0	47,0	0,5124	BF
x1000	235	380	47,7	50,7	0,5734	BF
650 x 180	-	-	17,6	20,6	0,0756	BFL
x 200	-	-	18,4	21,4	0,0882	BFL
x 225	-	-	19,3	22,3	0,1040	BFL
x 250	-	5	20,3	23,3	0,1197	BFL
x 280	-	20	21,4	24,4	0,1386	BFL
x 300	-	30	22,2	25,2	0,1512	BFL
x 315	-	37	22,7	25,7	0,1607	BFL
x 355	-	57	24,3	27,3	0,1859	BFL
x 400	-	80	26,0	29,0	0,2142	BFN
x 450	-	105	27,9	30,9	0,2457	BFN
x 500	-	130	29,7	32,7	0,2772	BFN
x 550	10	155	31,6	34,6	0,3087	BFN
x 560	15	160	32,0	35,0	0,3150	BF
x 600	35	180	33,5	36,5	0,3402	BF
x 630	50	195	34,7	37,7	0,3591	BF
x 650	60	205	35,4	38,4	0,3717	BF
x 700	85	230	37,3	40,3	0,4032	BF
x 710	90	235	37,7	40,7	0,4095	BF
x 750	110	255	39,2	42,2	0,4347	BF
x 800	135	280	41,1	44,1	0,4662	BF
x 900	185	330	44,9	47,9	0,5292	BF
x1000	235	380	48,7	51,7	0,5922	BF
700 x 180	-	-	18,6	21,6	0,0816	BFL
x 200	-	-	19,4	22,4	0,0952	BFL
x 225	-	-	20,3	23,3	0,1122	BFL
x 250	-	5	21,3	24,3	0,1292	BFL
x 280	-	20	22,5	25,5	0,1496	BFL
x 300	-	30	23,3	26,3	0,1632	BFL
x 315	-	37	23,9	26,9	0,1734	BFL
x 355	-	57	25,5	28,5	0,2006	BFN
x 400	-	80	27,3	30,3	0,2312	BFN
x 450	-	105	29,3	32,3	0,2652	BFN
x 500	-	130	31,2	34,2	0,2992	BFN
x 550	10	155	33,2	36,2	0,3332	BF
x 560	15	160	33,6	36,6	0,3400	BF
x 600	35	180	35,2	38,2	0,3672	BF
x 630	50	195	36,4	39,4	0,3876	BF
x 650	60	205	37,2	40,2	0,4012	BF
x 700	85	230	39,2	42,2	0,4352	BF

AxB (mm)	a (mm)	c (mm)	Weight		Effect. area Sef (m²)	Mehh. kontr.
			Design			
			mech (kg)	servo (kg)		
700 x 710	90	235	39,6	42,6	0,4420	BF
x 750	110	255	41,2	44,2	0,4692	BF
x 800	135	280	43,1	46,1	0,5032	BF
x 900	185	330	47,1	50,1	0,5712	BF
x1000	235	380	51,1	54,1	0,6392	BF
710 x 180	-	-	18,7	21,7	0,0828	BFL
x 200	-	-	19,5	22,5	0,0966	BFL
x 225	-	-	20,5	23,5	0,1139	BFL
x 250	-	5	21,5	24,5	0,1311	BFL
x 280	-	20	22,7	25,7	0,1518	BFL
x 300	-	30	23,5	26,5	0,1656	BFL
x 315	-	37	24,1	27,1	0,1760	BFL
x 355	-	57	25,7	28,7	0,2036	BFN
x 400	-	80	27,5	30,5	0,2346	BFN
x 450	-	105	29,5	32,5	0,2691	BFN
x 500	-	130	31,5	34,5	0,3036	BFN
x 550	10	155	33,5	36,5	0,3381	BF
x 560	15	160	33,9	36,9	0,3450	BF
x 600	35	180	35,5	38,5	0,3726	BF
x 630	50	195	36,7	39,7	0,3933	BF
x 650	60	205	37,5	40,5	0,4071	BF
x 700	85	230	39,5	42,5	0,4416	BF
x 710	90	235	39,9	42,9	0,4485	BF
x 750	110	255	41,5	44,5	0,4761	BF
x 800	135	280	43,5	46,5	0,5106	BF
x 900	185	330	47,5	50,5	0,5796	BF
x1000	235	380	51,5	54,5	0,6486	BF
750 x 180	-	-	19,5	22,5	0,0876	BFL
x 200	-	-	20,3	23,3	0,1022	BFL
x 225	-	-	21,3	24,3	0,1205	BFL
x 250	-	5	22,4	25,4	0,1387	BFL
x 280	-	20	23,6	26,6	0,1606	BFL
x 300	-	30	24,5	27,5	0,1752	BFL
x 315	-	37	25,1	28,1	0,1862	BFL
x 355	-	57	26,7	29,7	0,2154	BFN
x 400	-	80	28,6	31,6	0,2482	BFN
x 450	-	105	30,7	33,7	0,2847	BFN
x 500	-	130	32,7	35,7	0,3212	BFN
x 550	10	155	34,8	37,8	0,3577	BF
x 560	15	160	35,2	38,2	0,3650	BF
x 600	35	180	36,9	39,9	0,3942	BF
x 630	50	195	38,1	41,1	0,4161	BF
x 650	60	205	39,0	42,0	0,4307	BF
x 700	85	230	41,0	44,0	0,4672	BF
x 710	90	235	41,4	44,4	0,4745	BF
x 750	110	255	43,1	46,1	0,5037	BF
x 800	135	280	45,2	48,2	0,5402	BF
x 900	185	330	49,3	52,3	0,6132	BF
x1000	235	380	53,5	56,5	0,6862	BF
800 x 180	-	-	20,4	23,4	0,0936	BFL
x 200	-	-	21,3	24,3	0,1092	BFL
x 225	-	-	22,3	25,3	0,1287	BFL
x 250	-	5	23,4	26,4	0,1482	BFL

AxB (mm)	a (mm)	c (mm)	Weight		Effect. area Sef (m²)	Mehh. kontr.
			Design			
			mech (kg)	servo (kg)		
800 x 280	-	20	24,7	27,7	0,1716	BFL
x 300	-	30	25,6	28,6	0,1872	BFL
x 315	-	37	26,2	29,2	0,1989	BFL
x 355	-	57	28,0	31,0	0,2301	BFN
x 400	-	80	29,9	32,9	0,2652	BFN
x 450	-	105	32,1	35,1	0,3042	BFN
x 500	-	130	34,2	37,2	0,3432	BFN
x 550	10	155	36,4	39,4	0,3822	BF
x 560	15	160	36,8	39,8	0,3900	BF
x 600	35	180	38,6	41,6	0,4212	BF
x 630	50	195	39,9	42,9	0,4446	BF
x 650	60	205	40,7	43,7	0,4602	BF
x 700	85	230	42,9	45,9	0,4992	BF
x 710	90	235	43,3	46,3	0,5070	BF
x 750	110	255	45,0	48,0	0,5382	BF
x 800	135	280	47,2	50,2	0,5772	BF
x 900	185	330	51,5	54,5	0,6552	BF
x1000	235	380	55,9	58,9	0,7332	BF
900 x 180	-	-	22,2	25,2	0,1056	BFL
x 200	-	-	23,2	26,2	0,1232	BFL
x 225	-	-	24,3	27,3	0,1452	BFL
x 250	-	5	25,5	28,5	0,1672	BFL
x 280	-	20	26,9	29,9	0,1936	BFL
x 300	-	30	27,9	30,9	0,2112	BFL
x 315	-	37	28,6	31,6	0,2244	BFN
x 355	-	57	30,4	33,4	0,2596	BFN
x 400	-	80	32,5	35,5	0,2992	BFN
x 450	-	105	34,9	37,9	0,3432	BFN
x 500	-	130	37,2	40,2	0,3872	BF
x 550	10	155	39,6	42,6	0,4312	BF
x 560	15	160	40,0	43,0	0,4400	BF
x 600	35	180	41,9	44,9	0,4752	BF
x 630	50	195	43,3	46,3	0,5016	BF
x 650	60	205	44,3	47,3	0,5192	BF
x 700	85	230	46,6	49,6	0,5632	BF
x 710	90	235	47,1	50,1	0,5720	BF
x 750	110	255	48,9	51,9	0,6072	BF
x 800	135	280	51,3	54,3	0,6512	BF
x 900	185	330	56,0	59,0	0,7392	BF
x1000	235	380	60,6	63,6	0,8272	BF
1000x 180	-	-	24,1	27,1	0,1176	BFL
x 200	-	-	25,1	28,1	0,1372	BFL
x 225	-	-	26,4	29,4	0,1617	BFL
x 250	-	5	27,6	30,6	0,1862	BFL
x 280	-	20	29,1	32,1	0,2156	BFL
x 300	-	30	30,1	33,1	0,2352	BFN
x 315	-	37	30,9	33,9	0,2499	BFN
x 355	-	57	32,9	35,9	0,2891	BFN
x 400	-	80	35,2	38,2	0,3332	BFN
x 450	-	105	37,7	40,7	0,3822	BFN
x 500	-	130	40,2	43,2	0,4312	BF
x 550	10	155	42,7	45,7	0,4802	BF
x 560	15	160	43,2	46,2	0,4900	BF

AxB (mm)	a (mm)	c (mm)	Weight		Effect. area Sef (m²)	Mehh. kontr.
			Design			
			mech (kg)	servo (kg)		
1000x 600	35	180	45,3	48,3	0,5292	BF
x 630	50	195	46,8	49,8	0,5586	BF
x 650	60	205	47,8	50,8	0,5782	BF
x 700	85	230	50,3	53,3	0,6272	BF
x 710	90	235	50,8	53,8	0,6370	BF
x 750	110	255	52,8	55,8	0,6762	BF
x 800	135	280	55,3	58,3	0,7252	BF
x 900	185	330	60,4	63,4	0,8232	BF
x1000	235	380	65,4	68,4	0,9212	BF
1100x 180	-	-	25,9	28,9	0,1296	BFL
x 200	-	-	27,0	30,0	0,1512	BFL
x 225	-	-	28,4	31,4	0,1782	BFL
x 250	-	5	29,7	32,7	0,2052	BFL
x 280	-	20	31,3	34,3	0,2376	BFL
x 300	-	30	32,4	35,4	0,2592	BFN
x 315	-	37	33,2	36,2	0,2754	BFN
x 355	-	57	35,4	38,4	0,3186	BFN
x 400	-	80	37,8	40,8	0,3672	BFN
x 450	-	105	40,5	43,5	0,4212	BF
x 500	-	130	43,2	46,2	0,4752	BF
x 550	10	155	45,9	48,9	0,5292	BF
x 560	15	160	46,5	49,5	0,5400	BF
x 600	35	180	48,6	51,6	0,5832	BF
x 630	50	195	50,2	53,2	0,6156	BF
x 650	60	205	51,3	54,3	0,6372	BF
x 700	85	230	54,0	57,0	0,6912	BF
x 710	90	235	54,6	57,6	0,7020	BF
x 750	110	255	56,7	59,7	0,7452	BF
x 800	135	280	59,4	62,4	0,7992	BF
x 900	185	330	64,8	67,8	0,9072	BF
x1000	235	380	70,2	73,2	1,0152	BF
1250x 180	-	-	28,7	31,7	0,1476	BFL
x 200	-	-	29,9	32,9	0,1722	BFL
x 225	-	-	31,4	34,4	0,2030	BFL
x 250	-	5	32,8	35,8	0,2337	BFL
x 280	-	20	34,6	37,6	0,2706	BFN
x 300	-	30	35,8	38,8	0,2952	BFN
x 315	-	37	36,7	39,7	0,3137	BFN
x 355	-	57	39,1	42,1	0,3629	BFN
x 400	-	80	41,8	44,8	0,4182	BFN
x 450	-	105	44,7	47,7	0,4797	BF
x 500	-	130	47,7	50,7	0,5412	BF
x 550	10	155	50,7	53,7	0,6027	BF
x 560	15	160	51,3	54,3	0,6150	BF
x 600	35	180	53,6	56,6	0,6642	BF
x 630	50	195	55,4	58,4	0,7011	BF
x 650	60	205	56,6	59,6	0,7257	BF
x 700	85	230	59,6	62,6	0,7872	BF
x 710	90	235	60,2	63,2	0,7995	BF
x 750	110	255	62,6	65,6	0,8487	BF
x 800	135	280	65,5	68,5	0,9102	BF
x 900*	185	330	71,5	74,5	1,0332	BF
x1000*	235	380	77,4	80,4	1,1562	BF

* For these dimensions are used two closing springs

AxB (mm)	a (mm)	c (mm)	Weight		Effect. area Sef (m ²)	Mehh. kontr.
			Design			
			mech (kg)	servo (kg)		
1400x 180	-	-	31,4	34,4	0,1656	BFL
x 200	-	-	32,7	35,7	0,1932	BFL
x 225	-	-	34,4	37,4	0,2277	BFL
x 250	-	5	36,0	39,0	0,2622	BFN
x 280	-	20	37,9	40,9	0,3036	BFN
x 300	-	30	39,2	42,2	0,3312	BFN
x 315	-	37	40,2	43,2	0,3519	BFN
x 355	-	57	42,8	45,8	0,4071	BFN
x 400	-	80	45,7	48,7	0,4692	BF
x 450	-	105	48,9	51,9	0,5382	BF
x 500	-	130	52,2	55,2	0,6072	BF
x 550	10	155	55,4	58,4	0,6762	BF
x 560	15	160	56,1	59,1	0,6900	BF
x 600	35	180	58,7	61,7	0,7452	BF
x 630*	50	195	60,6	63,6	0,7866	BF
x 650*	60	205	61,9	64,9	0,8142	BF
x 700*	85	230	65,2	68,2	0,8832	BF
x 710*	90	235	65,8	68,8	0,8970	BF
x 750*	110	255	68,4	71,4	0,9522	BF
x 800*	135	280	71,6	74,6	1,0212	BF
x 900*	185	330	78,1	81,1	1,1592	BF
x1000*	235	380	84,6	87,6	1,2972	BF
1500x 180	-	-	33,3	36,3	0,1776	BFL
x 200	-	-	34,7	37,7	0,2072	BFL
x 225	-	-	36,4	39,4	0,2442	BFL
x 250	-	5	38,1	41,1	0,2812	BFN
x 280	-	20	40,1	43,1	0,3256	BFN
x 300	-	30	41,5	44,5	0,3552	BFN
x 315	-	37	42,5	45,5	0,3774	BFN
x 355	-	57	45,3	48,3	0,4366	BFN
x 400	-	80	48,3	51,3	0,5032	BF
x 450	-	105	51,8	54,8	0,5772	BF
x 500	-	130	55,2	58,2	0,6512	BF

AxB (mm)	a (mm)	c (mm)	Weight		Effect. area Sef (m ²)	Mehh. kontr.
			Design			
			mech (kg)	servo (kg)		
1500x 550	10	155	58,6	61,6	0,7252	BF
x 560	15	160	59,3	62,3	0,7400	BF
x 600	35	180	62,0	65,0	0,7992	BF
x 630*	50	195	64,1	67,1	0,8436	BF
x 650*	60	205	65,4	68,4	0,8732	BF
x 700*	85	230	68,9	71,9	0,9472	BF
x 710*	90	235	69,6	72,6	0,9620	BF
x 750*	110	255	72,3	75,3	1,0212	BF
x 800*	135	280	75,7	78,7	1,0952	BF
x 900*	185	330	82,6	85,6	1,2432	BF
x1000*	235	380	89,4	92,4	1,3912	BF
1600x 180	-	-	35,1	38,1	0,1896	BFL
x 200	-	-	36,6	39,6	0,2212	BFL
x 225	-	-	38,4	41,4	0,2607	BFL
x 250	-	5	40,2	43,2	0,3002	BFN
x 280	-	20	42,3	45,3	0,3476	BFN
x 300	-	30	43,8	46,8	0,3792	BFN
x 315	-	37	44,8	47,8	0,4029	BFN
x 355	-	57	47,7	50,7	0,4661	BFN
x 400	-	80	51,0	54,0	0,5372	BF
x 450	-	105	54,6	57,6	0,6162	BF
x 500	-	130	58,2	61,2	0,6952	BF
x 550	10	155	61,8	64,8	0,7742	BF
x 560	15	160	62,5	65,5	0,7900	BF
x 600	35	180	65,4	68,4	0,8532	BF
x 630*	50	195	67,5	70,5	0,9006	BF
x 650*	60	205	69,0	72,0	0,9322	BF
x 700*	85	230	72,6	75,6	1,0112	BF
x 710*	90	235	73,3	76,3	1,0270	BF
x 750*	110	255	76,2	79,2	1,0902	BF
x 800*	135	280	79,8	82,8	1,1692	BF
x 900*	185	330	87,0	90,0	1,3272	BF
x1000*	235	380	94,2	97,2	1,4852	BF

* For these dimensions are used two closing springs

3.3 Blades overlaps

Tab 3.3.1. Blades overlaps

Blades overlaps		Dimension	Overlaps
Blades overlaps Fig.14	Act. mechanism side	"a"	Tab. 3.2.1
	Side without act. mechanism	"c"	Tab. 3.2.1

These values have to respected when projecting related air-conditioning ducts

Fig. 14 Blades overlaps

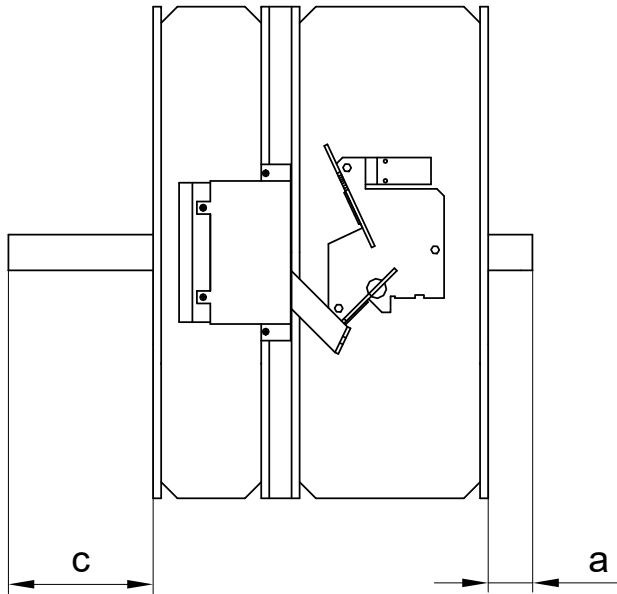

For the design .60 (with BKN supply and communication device) add to weight of the damper with an actuating mechanism (from the Tab 4.2.1.) the weight of BKN...0,5 kg.

Dampers can be supplied on the customer's demands in all subdimension of the above mentioned range.

Flanges of dampers are 30 mm wide with oval hole (Fig. 15).

Fig. 15 Flange of Damper

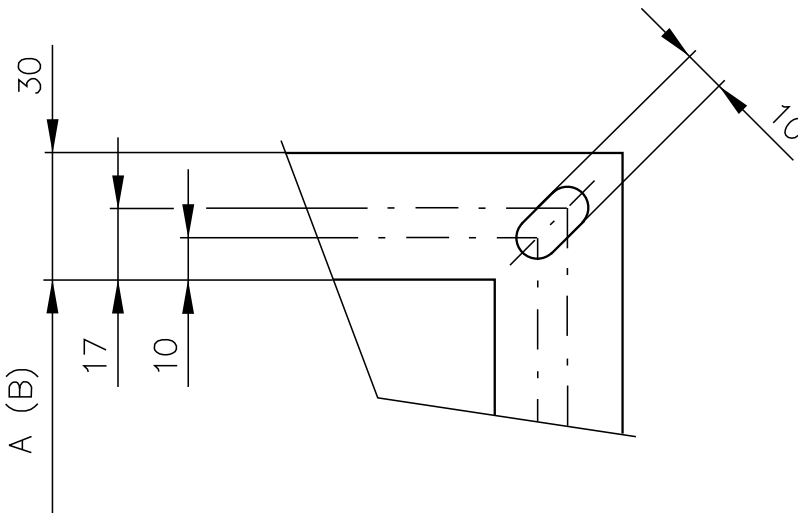

4. Placement and Assembly

4.1

Fire dampers are suitable for installation in arbitrary position in vertical and horizontal passages of fire separating constructions. Damper assembly procedures must be done so as all load transfer from the fire separating constructions to the damper body is absolutely excluded. Back-to-back air-conditioning piping must be hung or supported so as all load transfer from the back-to-back piping to the damper is absolutely excluded. Installation gap must be filled by approved material perfectly in all the installation space volume (installation gap).

To provide needed access space to the control device, all other objects must be situated at least 350 mm from the control parts of the damper. Inspection hole must be accessible. Damper blade has to be inside of construction (labelled with BUILD IN EDGE on the damper body) after installation. The fire damper can also be installed outside the wall construction. Duct and the damper part between the wall construction and the damper blade (labelled with BUILD IN EDGE on the protective covering) must be protected with firefighting insulation.

The distance between the fire damper and the construction (wall, ceiling) must be minimum 75 mm. In case that two or more dampers are supposed to be installed in one fire separating construction, the distance between the adjacent dampers must be at least 200 mm according to EN 1366-2 paragraph 13.5.

Exceptions are given in chapter 5.

Fig. 16 The distance between the fire damper and the construction

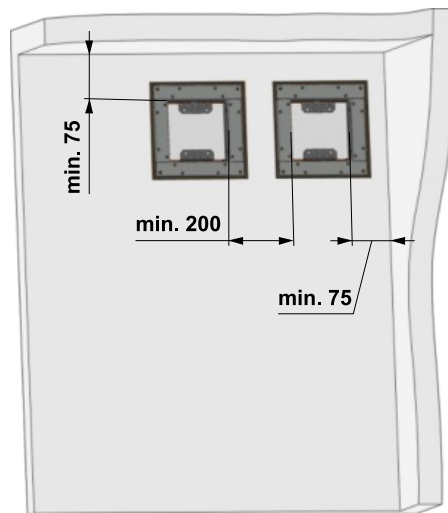
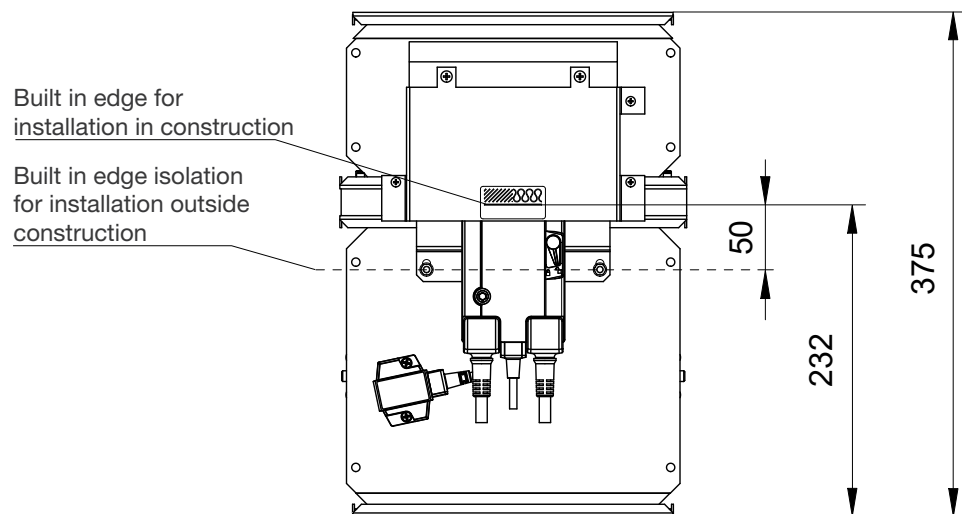

Fig. 17 Built in edge



"Wall edge sticker" indicates the recommended edge of installation of fire damper into the fire partition structure (wall).

The damper must be installed so that the entire damper blade - in the closed position - is located inside the fire separating structure (wall) and at the same time the control mechanism and inspection openings are freely accessible.

Fig. 18 Installation opening

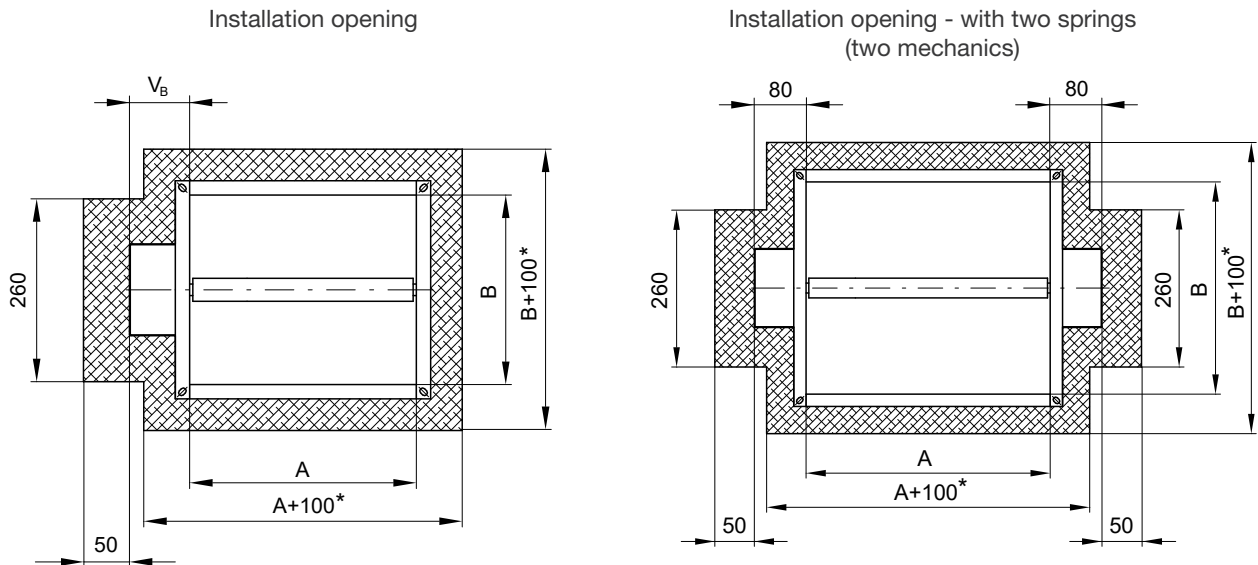

$V_B = 80$... mechanics
 125 ... BELIMO actuators
 145 ... SCHISCHEK actuators

* The recommended dimension of the installation opening is from 25 mm to 50 mm on the both sides (it means from $A+50$ to $A+100$ or $B+50$ to $B+100$)

Installation opening
 Weichschott / Ablative Coated Batt

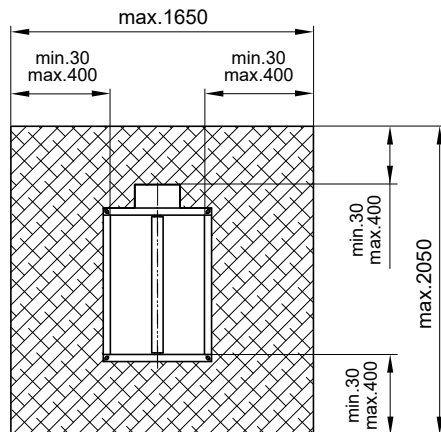

4.2 Examples of fire damper installing

The fire damper can be integrated into a solid wall construction made e.g. of normal concrete/ masonry, porous concrete with minimum thickness 100 mm or into solid ceiling construction made e.g. of normal concrete with minimum thickness 110 mm or porous concrete with minimum thickness 125 mm.

The fire damper can be integrated into a gypsum wall construction with fire classification EI 120 or EI 90.

The fire damper can also be integrated outside the wall construction. Duct and the damper part between the wall construction and the damper blade (labelled with BUILD IN EDGE on the protective covering) must be protected with fire-fighting insulation.

If is damper installed outside a construction it is necessary to use reinforcement VRM-Q.

Important: For lower fire resistance than EI90 the reinforcement VRM-Q is not necessary!!!

5. Statement of installations

5.1 Installation method list

Tab 5.1.1.

Fire separating constru.	Wall/Ceiling	Installation	Fire resist.	Page
	Min.thickness [mm]			
Solid wall construction	100	Mortar or gypsum	EIS 120 EIS 90	19
	100	Fire protection foam with stucco plaster	EIS 60 EIS 45 EIS 30	19
	100	Installation next to wall/ceiling - mortar or gypsum and mineral wool	EIS 90	20
	100	Stuffing box with fire protection mastic and cement lime plate	EIS 90	21
	100	Weichschott / Ablative Coated Batt	EIS 90	22
Outside solid wall construction	100	Mineral wool - mortar or gypsum	EIS 60	23
	100	Mineral wool - stuffing box and fire protection mastic	EIS 60	24
	100	Mineral wool, stuffing box, fire protection mastic and cement lime plate	EIS 90	24
Gypsum wall construction	100	Mortar or gypsum	EIS 120 EIS 90	25
	100	Fire protection foam with stucco plaster	EIS 60 EIS 45 EIS 30	25
	100	Stuffing box with fire protection mastic and cement lime plate	EIS 90	26
	100	Weichschott / Ablative Coated Batt	EIS 90	27
Outside gypsum wall construction	100	Mineral wool - mortar or gypsum	EIS 60	28
	100	Mineral wool - stuffing box and fire protection mastic	EIS 60	28
	100	Mineral wool, stuffing box, fire protection mastic and cement lime plate	EIS 90	29
Solid ceiling construction	110 - Concrete 125 - Aerated concrete	Mortar or gypsum	EIS 120 EIS 90	30
		Stuffing box with fire protection mastic and cement lime plate	EIS 90	31
		Weichschott / Ablative Coated Batt	EIS 90	32
Outside solid ceiling construction	110 - Concrete 125 - Aerated concrete	Mineral wool - mortar or gypsum	EIS 90	33

5.2 Installation in solid wall construction

Fig. 19 Solid wall construction - mortar or gypsum

** the requirement to EIS 120 must be specified in the order alone. Without specifications is supplied the standard flap EIS 90

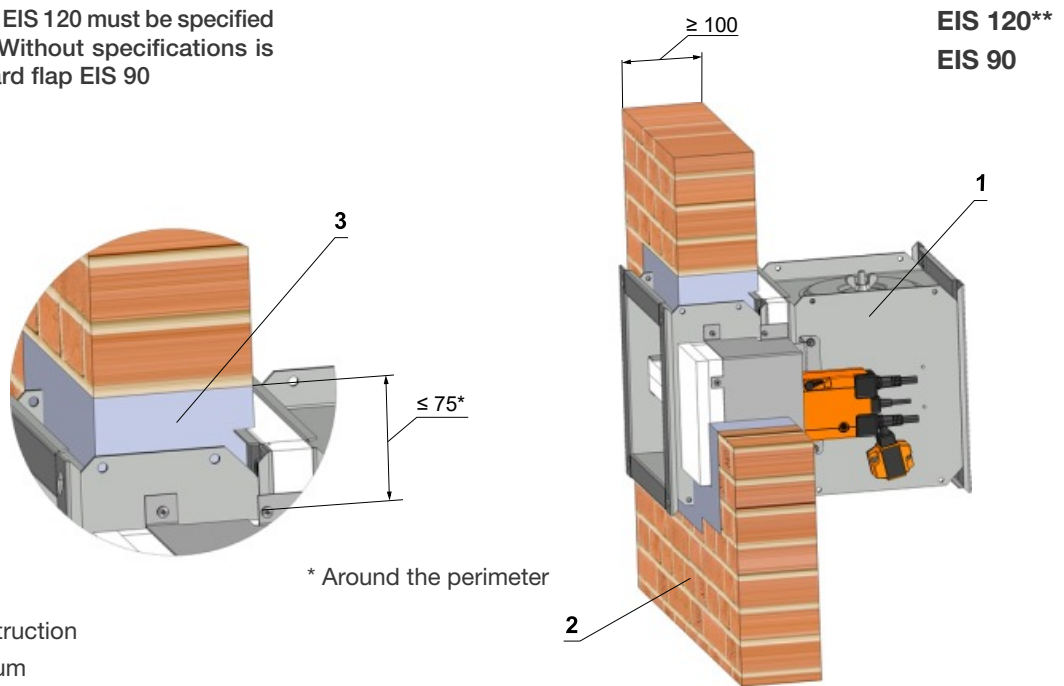

Position:

- 1 – Fire damper
- 2 – Solid wall construction
- 3 – Mortar or gypsum

* Around the perimeter

Fig. 20 Solid wall construction - Fire protection foam with stucco plaster

Maximal damper dimensions 400 x 400 mm

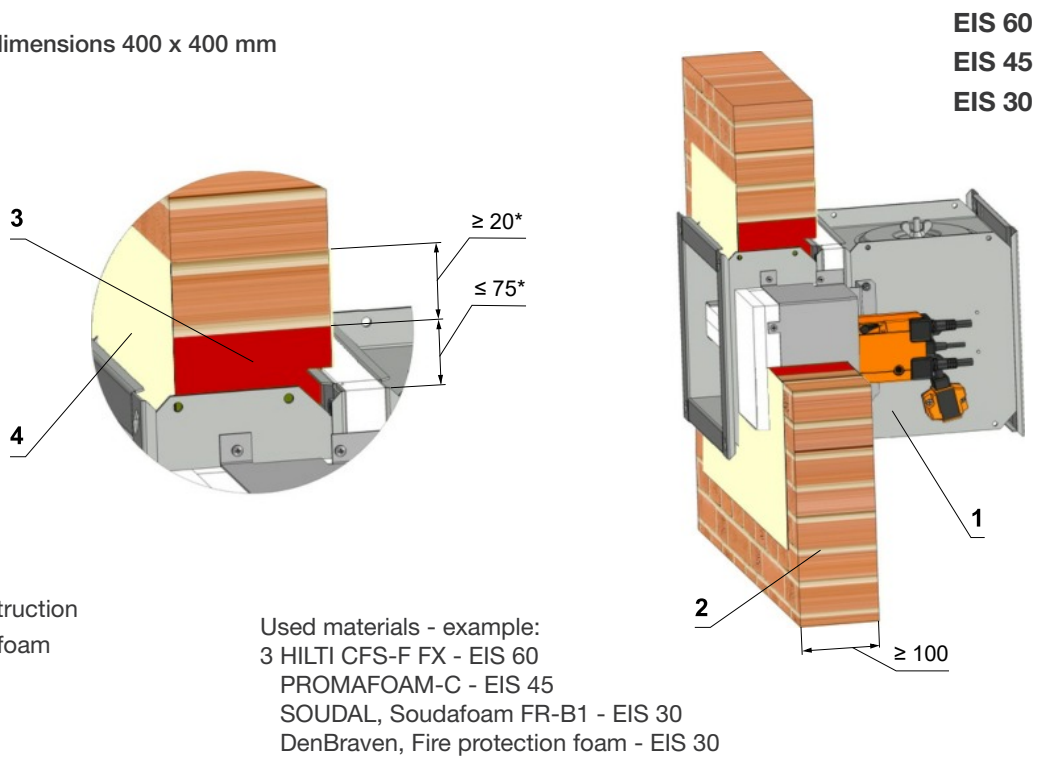

Position:

- 1 – Fire damper
- 2 – Solid wall construction
- 3 – Fire protection foam
- 4 – Stucco plaster

Used materials - example:
 3 HILTI CFS-F FX - EIS 60
 PROMAFOAM-C - EIS 45
 SOUDAL, Soudafoam FR-B1 - EIS 30
 DenBraven, Fire protection foam - EIS 30

Fig. 21 Solid wall construction - Installation next to wall/ceiling - mortar or gypsum and mineral wool

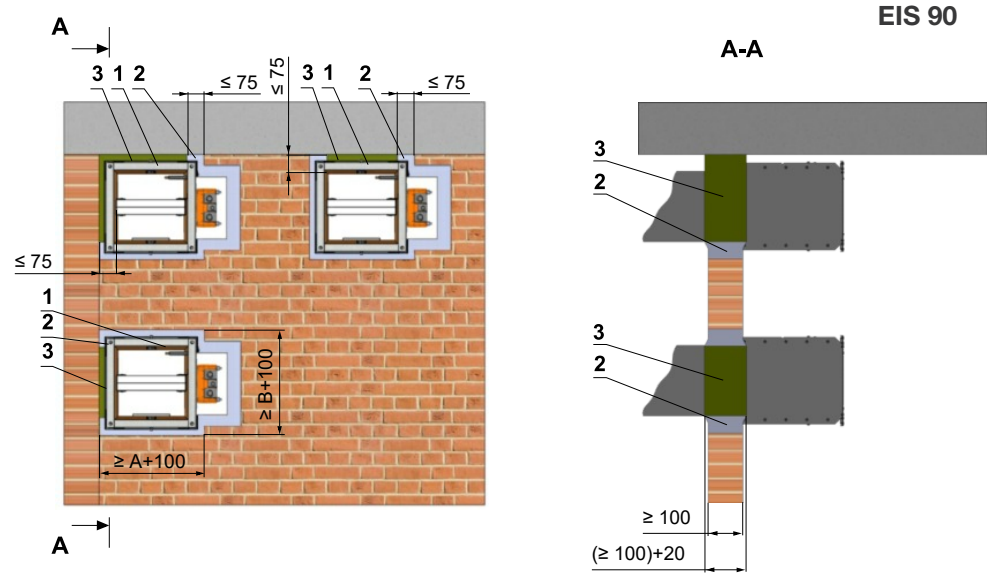

Position:

- 1 – Fire damper
- 2 – Mortar or gypsum
- 3 – Mineral stone wool min. density 140 kg/m³

Notice:

- Gap between damper and construction is filled by mortar or gypsum and mineral wool
- Wool is fixed to damper body and construction by fire protection mastic
- Mineral wool thickness = construction thickness + 20 mm or 50 mm
- Installation is valid for ceiling construction

Fig. 22 Solid wall construction - Stuffing box with fire protection mastic and cement lime platel

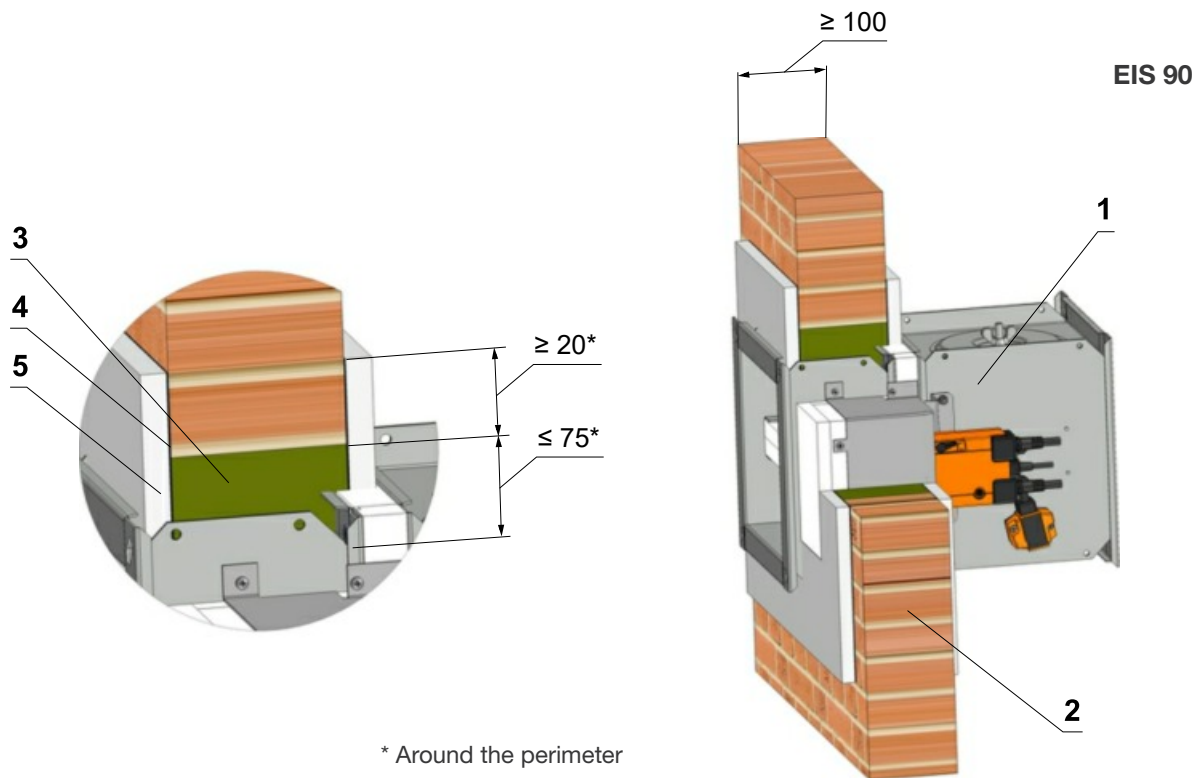

* Around the perimeter

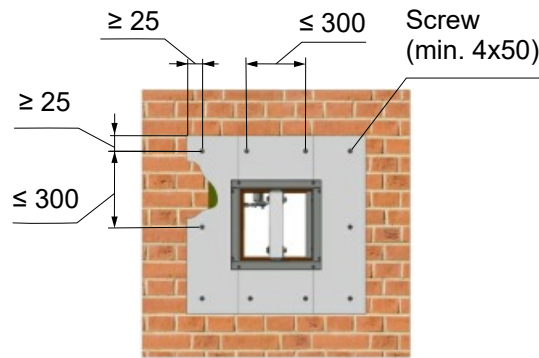

Screws has to be fixed in wall/ceiling construction.
(If it is needed use steel bracket).

Position:

- 1 – Fire damper
- 2 – Solid wall construction
- 3 – Mineral stone wool min. density 140 kg/m³
- 4 – Fire protection mastic min. thickness 1 mm
- 5 – Cement lime platel min. thickness 15 mm min. density 870 kg/m³

Used materials - example:

- 3 Promapyr, Rockwool Steprock HD, Hilti CFS-CT B 1S 140/50
- 4 Promastop - P, K, Hilti CFS-CT
- 5 Promatect - H

Fig. 23 Solid wall construction - Weichschott / Ablative Coated Batt

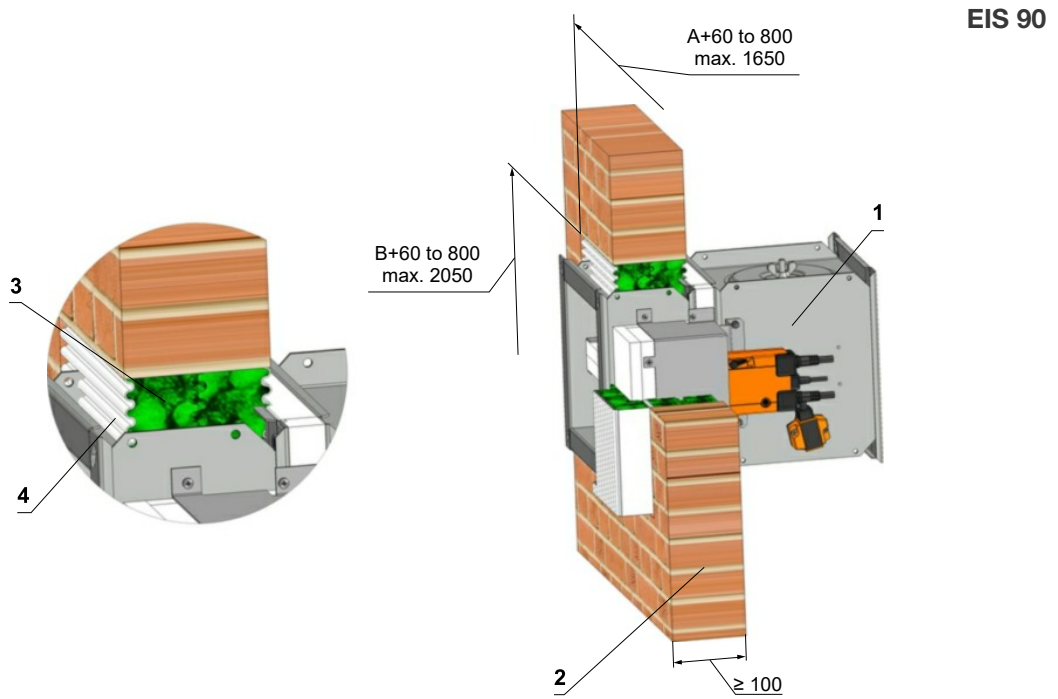

Position:

- 1 – Fire damper
- 2 – Solid wall construction
- 3 – Fire resistant board
- 4 – Fire stop coating thickness 1 mm

Used materials - example:*

- 3 Hilti CFS-CT B 1S 140/50
- 4 Hilti CFS-CT

5.3 Installation outside solid wall construction

Fig. 24 Outside solid wall construction - mineral wool - mortar or gypsum

Minimum and maximum distance between the wall and fire damper when installation remote from the wall is unlimited.

EIS 60

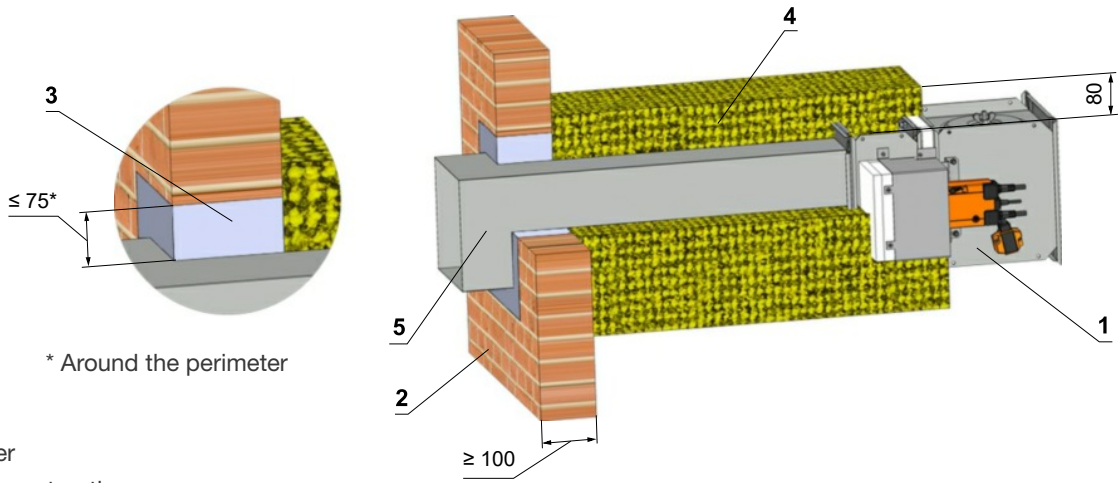

* Around the perimeter

Position:

- 1 – Fire damper
- 2 – Solid wall construction
- 3 – Mortar or gypsum
- 4 – Insulation board made of stone wool, with a surface treatment of aluminum foil, density 66 kg/m³
- 5 – Duct

Used materials - example:**

- 4 Isover Ultimate Protect SLAB 4.0, th. 80 mm ALU1

** Insulation materials can be replaced by another approved fire sealing system with equivalent properties. The maximum distance of the fire damper from the structure is not limited.

The duct at point of penetration does not have to be anchored to the fire wall construction, see chapter 6.

Fig. 25 Outside solid wall construction - mineral wool - stuffing box and fire protection mastic

Minimum and maximum distance between the wall and fire damper when installation remote from the wall is unlimited.

EIS 60

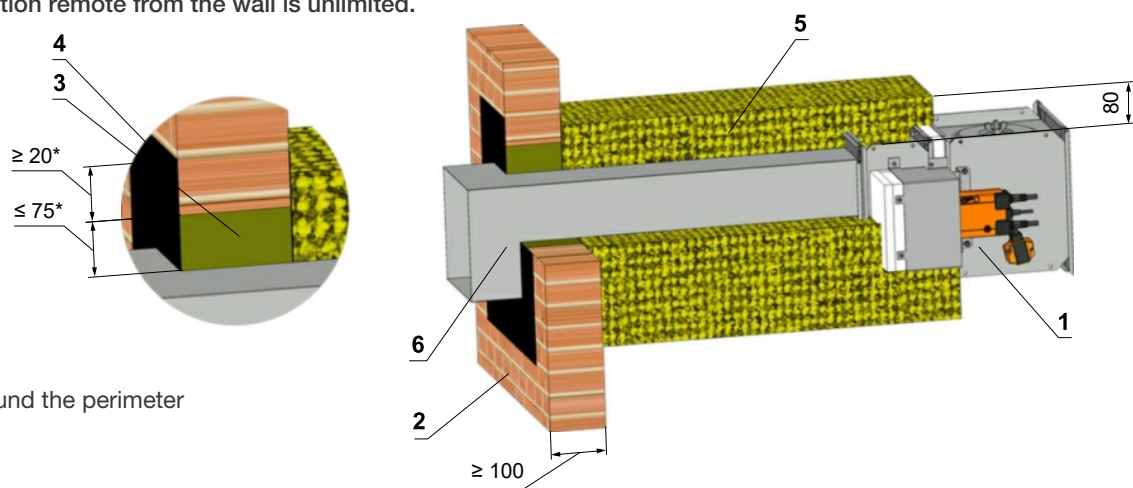

* Around the perimeter

Position:

- 1 – Fire damper
- 2 – Solid wall construction
- 3 – Stuffing box (mineral stone wool min. density 140 kg/m³)
- 4 – Fire protection mastic min. thickness 1 mm
- 5 – Insulation board made of stone wool, with a surface treatment of aluminum foil, density 66 kg/m³
- 6 – Duct

Used materials - example:**

- 3 Promapyr, Rockwool Steprock HD, Hilti CFS-CT B 1S 140/50
- 4 Promastop - P, K, Hilti CFS-CT
- 5 Isover Ultimate Protect SLAB 4.0, th. 80 mm ALU1

** Insulation materials can be replaced by another approved fire sealing system with equivalent properties. The maximum distance of the fire damper from the structure is not limited.

The duct at point of penetration must be anchored to the fire wall construction, see chapter 6.

Fig. 26 Outside solid wall construction - Mineral wool, stuffing box, fire protection mastic and cement lime plate

Minimum and maximum distance between the wall and fire damper when installation remote from the wall is unlimited.

EIS 90

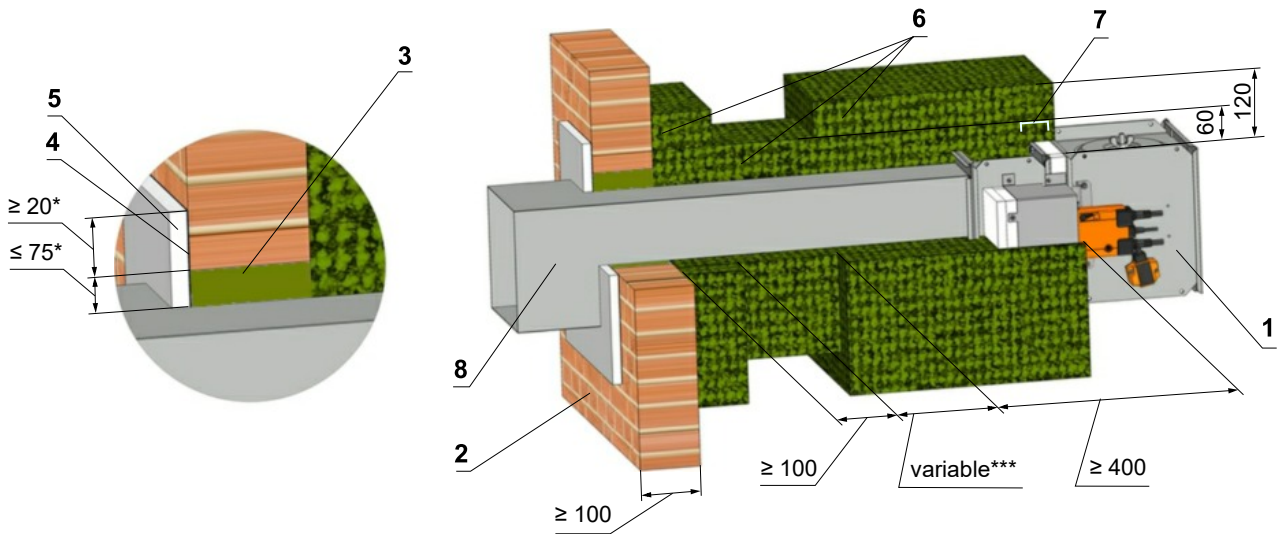

* Around the perimeter

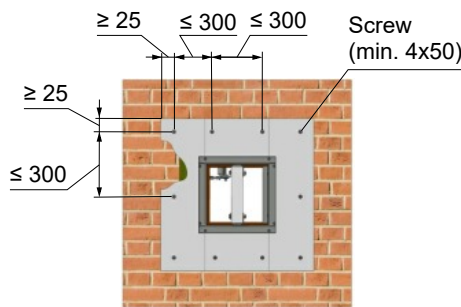

Screws has to be fixed in wall/ceiling construction.
(If it is needed use steel bracket).

Position:

- 1 – Fire damper
- 2 – Solid wall construction
- 3 – Mineral stone wool min. density 140 kg/m³
- 4 – Fire protection mastic min. thickness 1 mm
- 5 – Cement lime plate min. thickness 15 mm (min. density 870 kg/m³)
- 6 – Stone wool bound with use of an organic resin with crushed stone as a refrigerant, min. density 300 kg/m³ and min. thickness 60 mm
- 7 – Profil U25x40x25 ****
- 8 – Duct

Used materials - example:**

- 3 Promapyr, Rockwool Steprock HD, Hilti CFS-CT B 1S 140/50
- 4 Promastop - P, K, Hilti CFS-CT
- 5 Promatect - H
- 6 Rockwool Wired Mat 105 th. 60 mm

** Stuffing box, fire protection mastic, cement lime plate and insulation materials can be replaced by another approved fire sealing system for damper installation with equivalent material properties.

*** Depends on the distance of the flap from the construction, when the maximum distance from the construct is not limited and according to EN 15882-2 must use the required number of hinges according to EN 13366-1:2014.

**** Installation of profile U25x40x25 see Fig.57

The duct at point of penetration must be anchored to the fire wall construction, see chapter 6.

5.4 Installation in gypsum wall construction

Fig. 27 Gypsum wall construction - mortar or gypsum

** the requirement to EIS 120 must be specified in the order alone. Without specifications is supplied the standard flap EIS 90

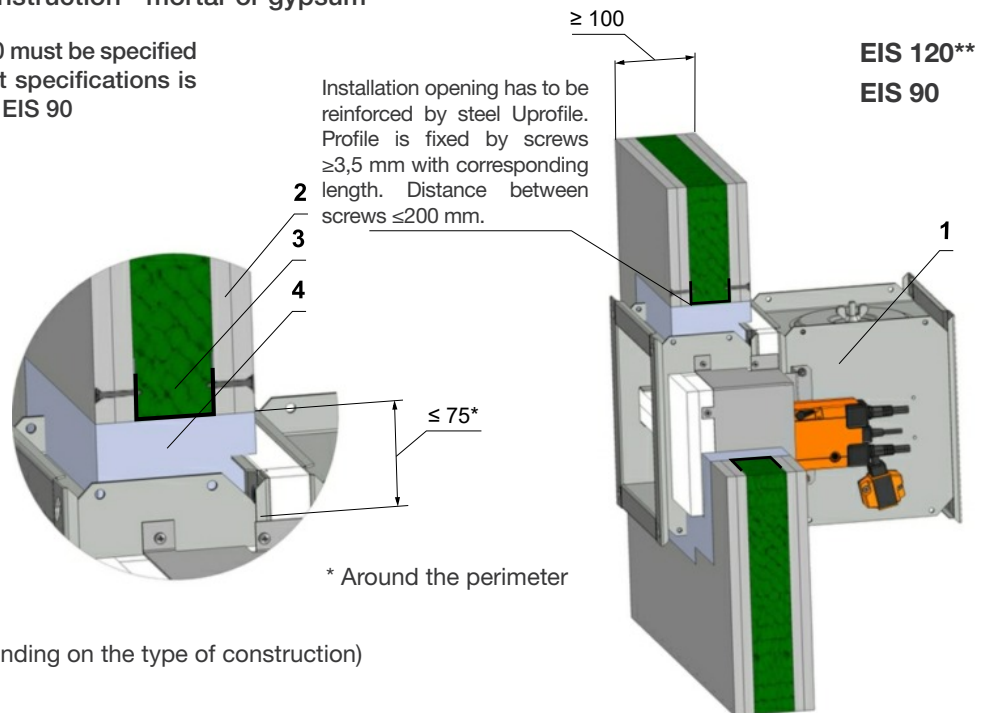

Position:

- 1 – Fire damper
- 2 – Gypsum plate
- 3 – Mineral wool (type depending on the type of construction)
- 4 - Mortar or gypsum

* Around the perimeter

Fig. 28 Gypsum wall construction - fire protection foam with stucco plaster

Maximal damper dimensions 400 x 400 mm

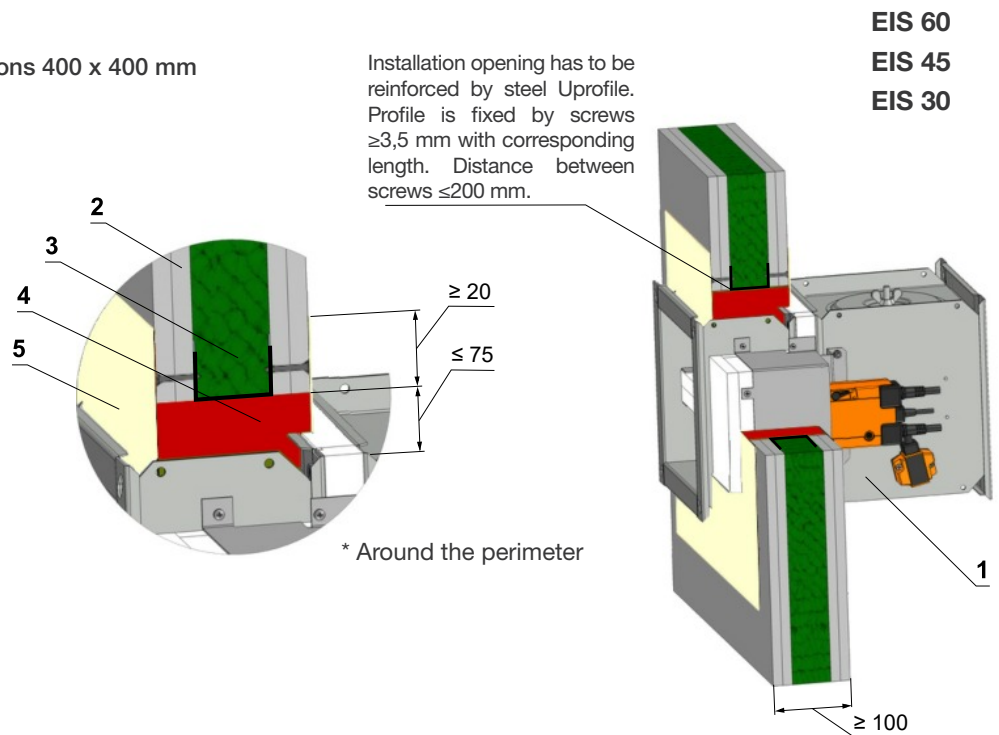

Position:

- 1 – Fire damper
- 2 – Gypsum plate
- 3 – Mineral wool (type depending on the type of construction)
- 4 – Fire protection foam
- 5 – Stucco plaster

* Around the perimeter

Used materials - example:
 4 HILTI CFS-F FX - EIS 60
 PROMAFOAM-C - EIS 45
 SOUDAL, Soudafoam FR-B1 - EIS 30
 DenBraven, Fire protection foam - EIS 30

Fig. 29 Gypsum wall construction - Stuffing box, fire protection mastic and cement lime plate

EIS 90

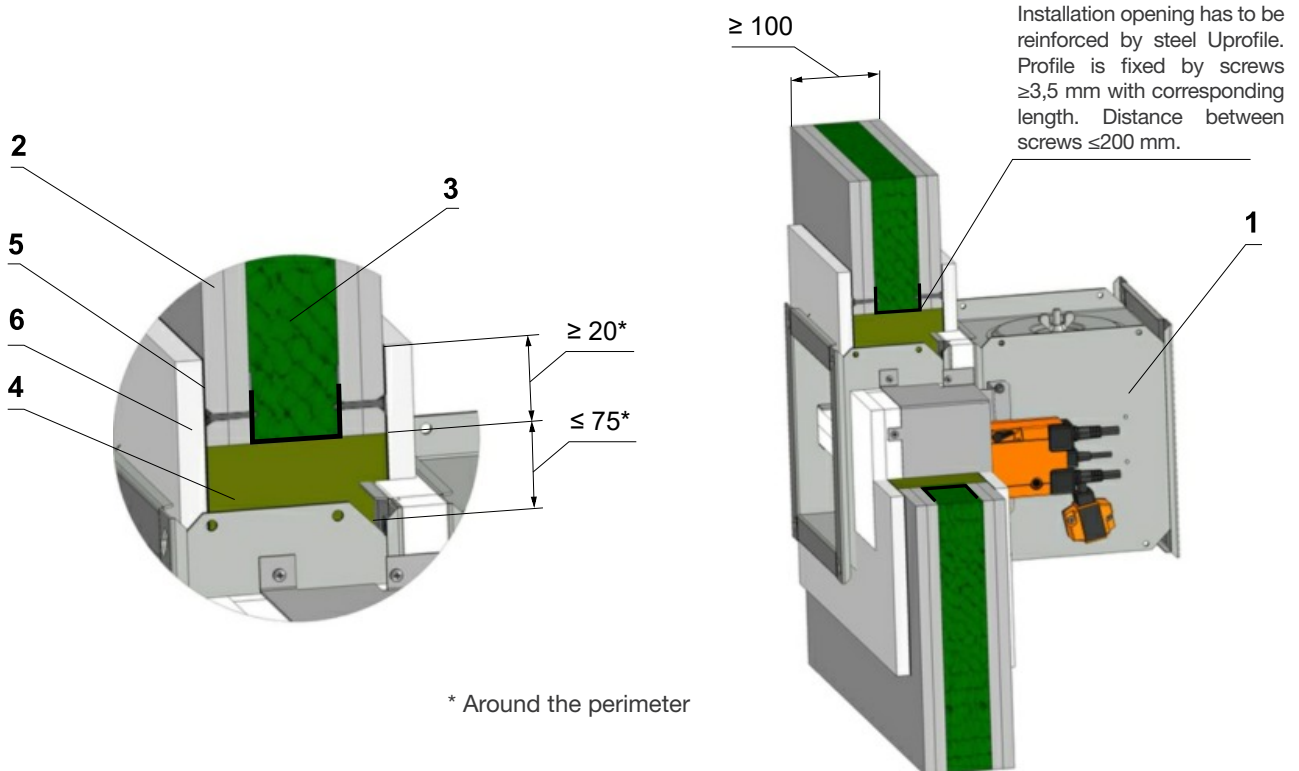

* Around the perimeter

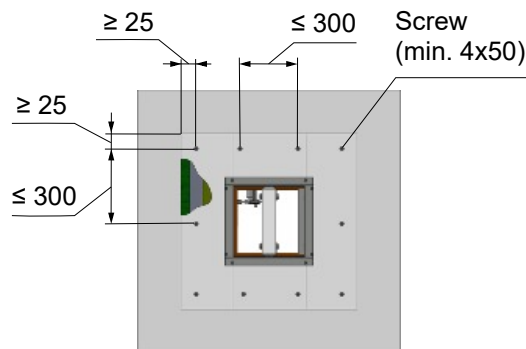

Position:

- 1 – Fire damper
- 2 – Gypsum plate
- 3 – Mineral wool (type depending on the type of construction)
- 4 – Mineral stone wool min. density 140 kg/m³
- 5 – Fire protection mastic min. thickness 1 mm
- 6 – Cement lime plate min. thickness 15 mm (min. density 870 kg/m³)

Used materials - example:

- 4 Promapyr, Rockwool Steprock HD, Hilti CFS-CT B 1S 140/50
- 5 Promastop - P, K, Hilti CFS-CT
- 6 Promatect - H

Fig. 30 Gypsum wall construction - Weichschott / Ablative Coated Batt

EIS 90

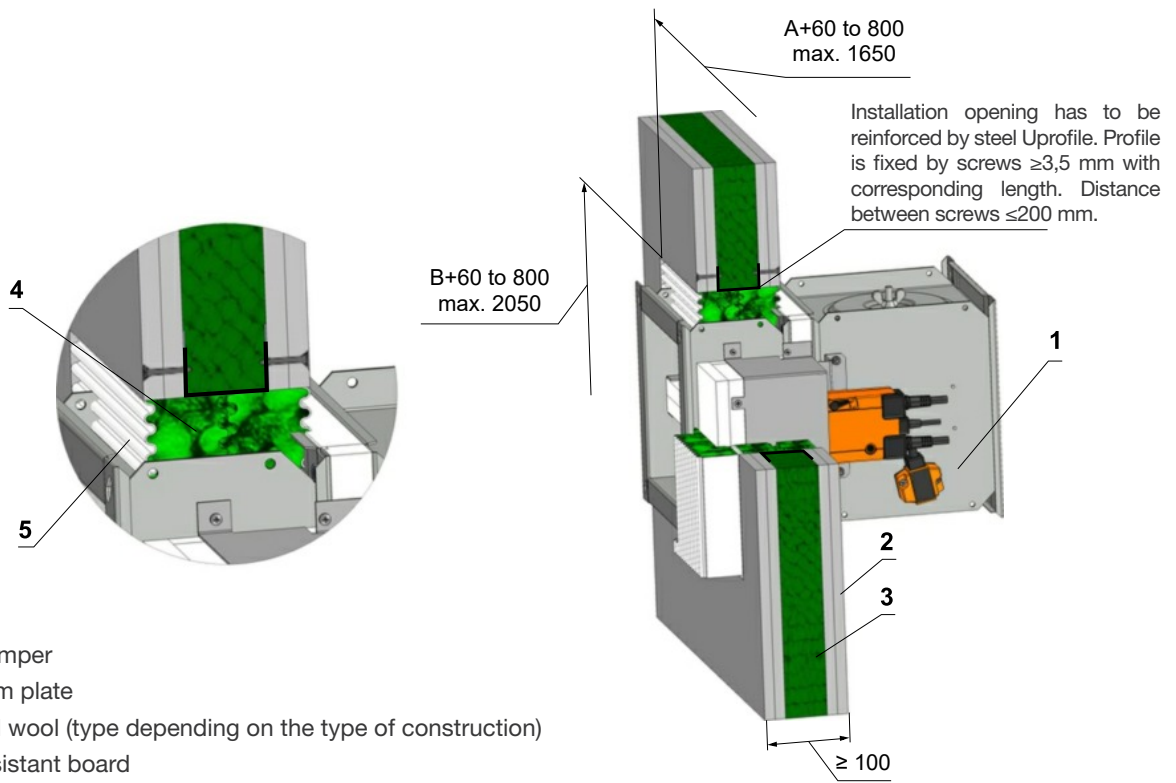

Position:

- 1 – Fire damper
- 2 – Gypsum plate
- 3 – Mineral wool (type depending on the type of construction)
- 4 – Fire resistant board
- 5 – Fire stop coating thickness 1 mm

Used materials - example:*

- 3 Hilti CFS-CT B 1S 140/50
- 4 Hilti CFS-CT

5.5 Installation outside gypsum wall construction

Fig. 31 Outside gypsum wall construction - Mineral wool - mortar or gypsum

Minimum and maximum distance between the wall and fire damper when installation remote from the wall is unlimited.

Installation opening has to be reinforced by steel Uprofile. Profile is fixed by screws $\geq 3,5$ mm with corresponding length. Distance between screws ≤ 200 mm.

EIS 60

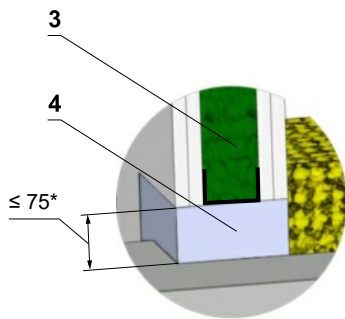

* Around the perimeter

Position:

- 1 – Fire damper
- 2 – Gypsum plate
- 3 – Mineral wool (type depending on the type of construction)
- 4 – Mortar or gypsum
- 5 – Insulation board made of stone wool, with a surface treatment of aluminum foil, density 66 kg/m³
- 6 – Duct

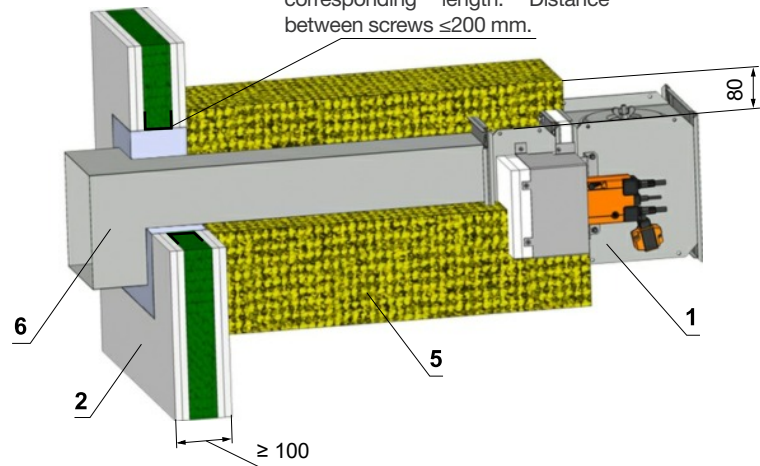

Used materials - example:**

- 5 Isover Ultimate Protect SLAB 4.0, th. 80 mm ALU1

** Insulation materials can be replaced by another approved fire sealing system with equivalent properties. The maximum distance of the fire damper from the structure is not limited.

The duct at point of penetration does not have to be anchored to the fire wall construction, see chapter 6.

Fig. 32 Outside gypsum wall construction - Mineral wool - stuffing box and fire protection mastic

Minimum and maximum distance between the wall and fire damper when installation remote from the wall is unlimited.

Installation opening has to be reinforced by steel Uprofile. Profile is fixed by screws $\geq 3,5$ mm with corresponding length. Distance between screws ≤ 200 mm.

EIS 60

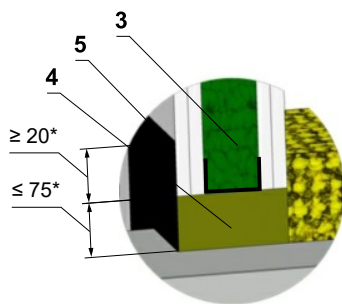

* Around the perimeter

Position:

- 1 – Fire damper
- 2 – Gypsum plate
- 3 – Mineral wool (type depending on the type of construction)
- 4 – Stuffing box (mineral stone wool min. density 140 kg/m³)
- 5 – Fire protection mastic min. thickness 1 mm
- 6 – Insulation board made of stone wool, with a surface treatment of aluminum foil, density 66 kg/m³
- 7 – Duct

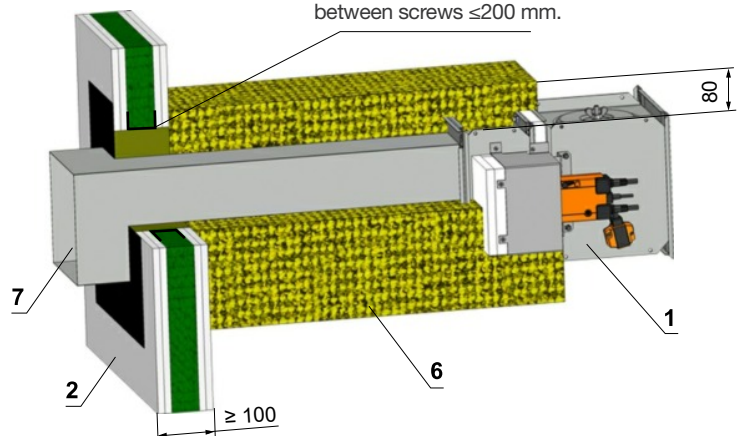

Used materials - example:**

- 4 Promapyr, Rockwool Steprock HD, Hilti CFS-CT B 1S 140/50
- 5 Promastop - P, K, Hilti CFS-CT
- 6 Isover Ultimate Protect SLAB 4.0, th. 80 mm ALU1

** Insulation materials can be replaced by another approved fire sealing system with equivalent properties. The maximum distance of the fire damper from the structure is not limited.

The duct at point of penetration must be anchored to the fire wall construction, see chapter 6.

Fig. 33 Outside gypsum wall construction - Mineral wool, stuffing box, fire protection mastic and cement lime plate

Minimum and maximum distance between the wall and fire damper when installation remote from the wall is unlimited.

EIS 90

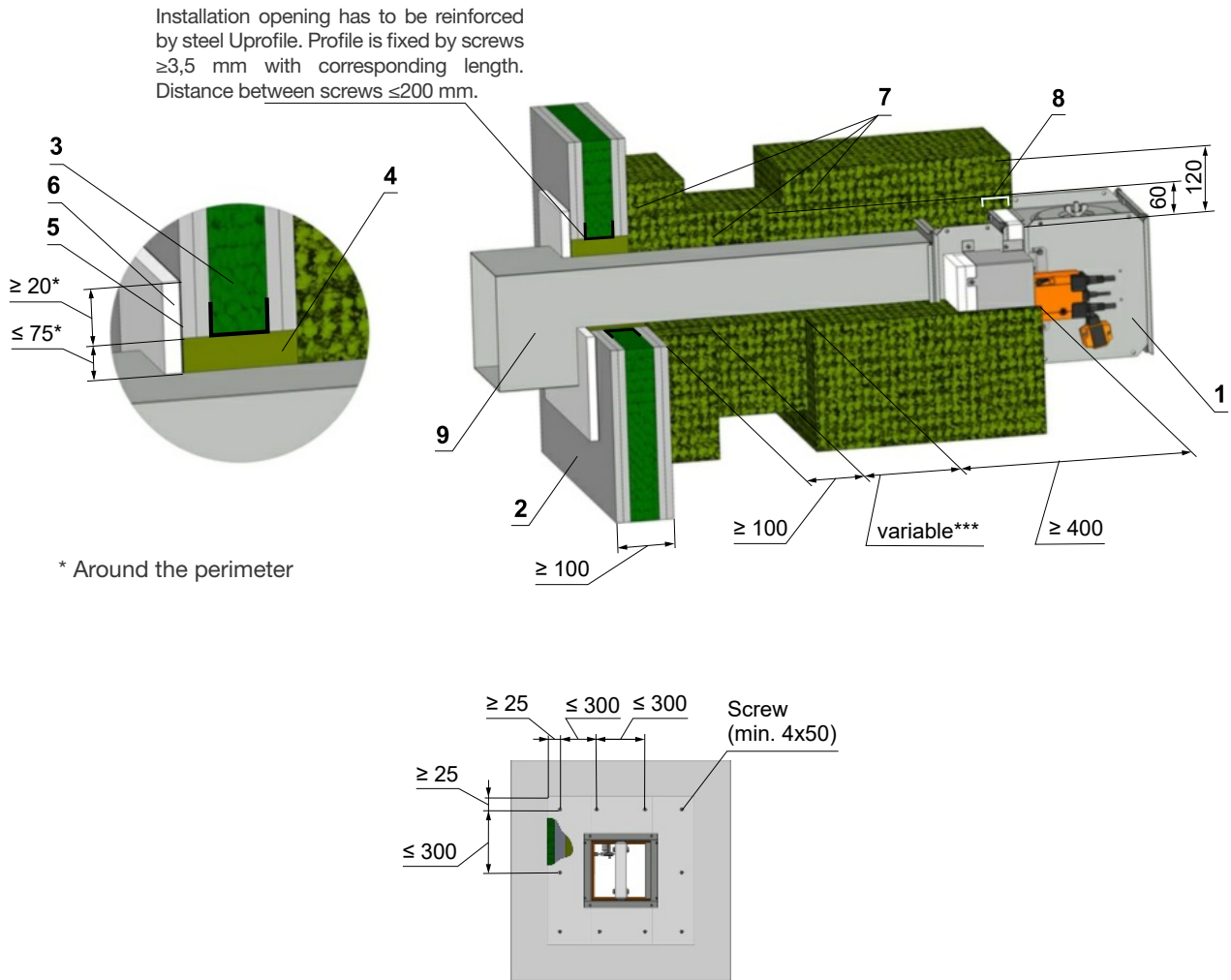

Screws has to be fixed in wall/ceiling construction.
(If it is needed use steel bracket).

Position:

- 1 – Fire damper
- 2 – Gypsum plate
- 3 – Mineral wool (type depending on the type of construction)
- 4 – Mineral stone wool min. density 140 kg/m^3
- 5 – Fire protection mastic min. thickness 1 mm
- 6 – Cement lime plate min. thickness 15 mm (min. density 870 kg/m^3)
- 7 – Stone wool bound with use of an organic resin with crushed stone as a refrigerant, min. density 300 kg/m^3 and min. thickness 60 mm
- 8 – Profil U25x40x25 ****
- 9 – Duct

Used materials - example:**

- 4 Promapyr. Rockwool Steprock HD. Hilti CFS-CT C 1S 140/50
- 5 Promastop - P, K, Hilti CFS-CT
- 6 Promatect - H
- 7 Rockwool Wired Mat 105 th. 60 mm

** Stuffing box, fire protection mastic, cement lime plate and insulation materials can be replaced by another approved fire sealing system for damper installation with equivalent material properties.

*** Depends on the distance of the flap from the construction, when the maximum distance from the construct is not limited and according to EN 15882-2 must use the required number of hinges according to EN 13366-1:2014.

**** Installation of profile U25x40x25 see Fig.57

The duct at point of penetration must be anchored to the fire wall construction, see chapter 6.

5.6 Installation in solid ceiling construction

Fig. 34 Solid ceiling construction - mortar or gypsum

*** the requirement to EIS 120 must be specified in the order alone. Without specifications is supplied the standard flap EIS 90

EIS 120***
EIS 90

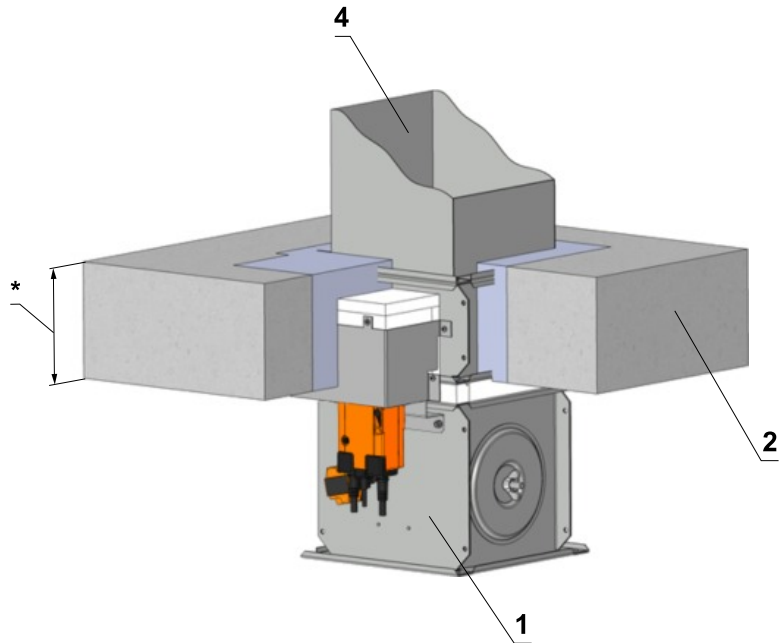
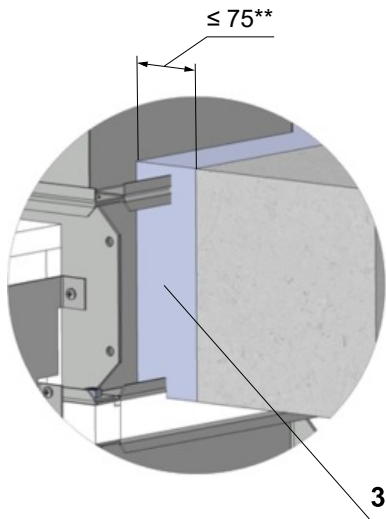

- Position:
- 1 – Fire damper
 - 2 – Solid ceiling construction
 - 3 – Mortar or gypsum
 - 4 – Duct

* min. 110 - Concrete/ min. 125 - Aerated concrete
** Around the perimeter

Fig. 35 Solid ceiling construction - stuffing box, fire protection mastic and cement lime plate

EIS 90

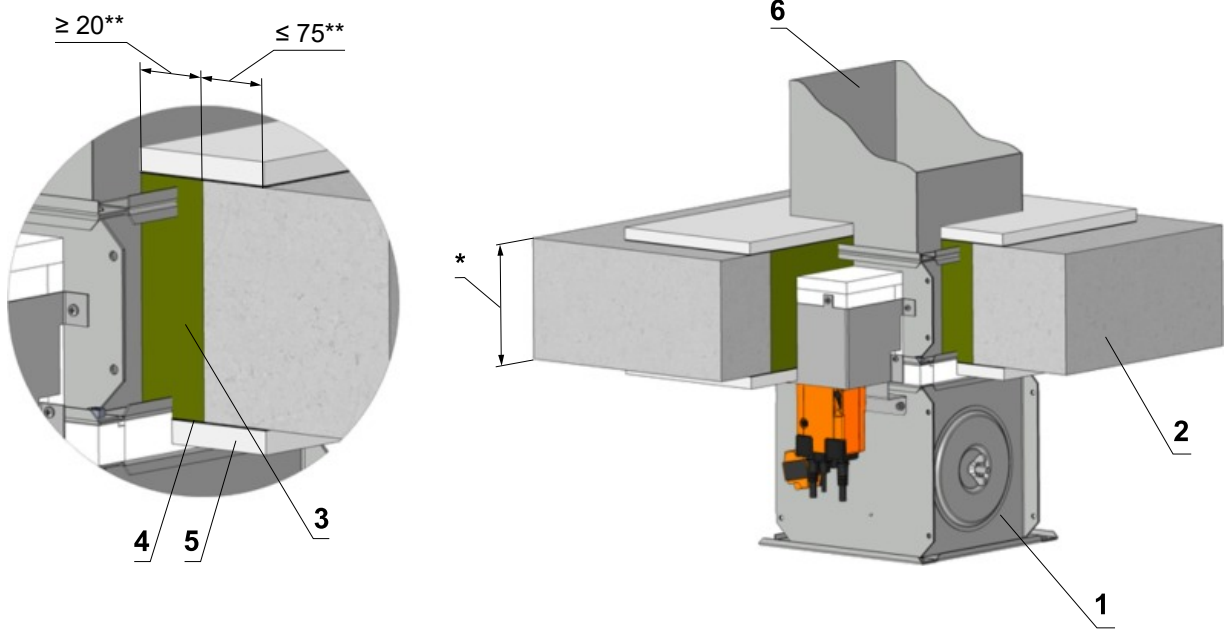

Screws has to be fixed in wall/ceiling construction.
(If it is needed use steel bracket).

Position:

- 1 – Fire damper
- 2 – Solid ceiling construction
- 3 – Stuffing box (mineral stone wool min. density 140 kg/m³)
- 4 – Fire protection mastic min. thickness 1 mm
- 5 – Cement lime plate min. thickness 15 mm, min. density 870 kg/m³
- 6 - Duct

* min. 110 - Concrete/ min. 125 - Aerated concrete
** Around the perimeter

Used materials - example:
3 Promapyr. Rockwool Steprock HD. Hilti CFS-CT C 1S 140/50
4 Promastop - P, K, Hilti CFS-CT
5 Promatect - H

Fig. 36 Solid ceiling construction - Weichschott / Ablative Coated Batt

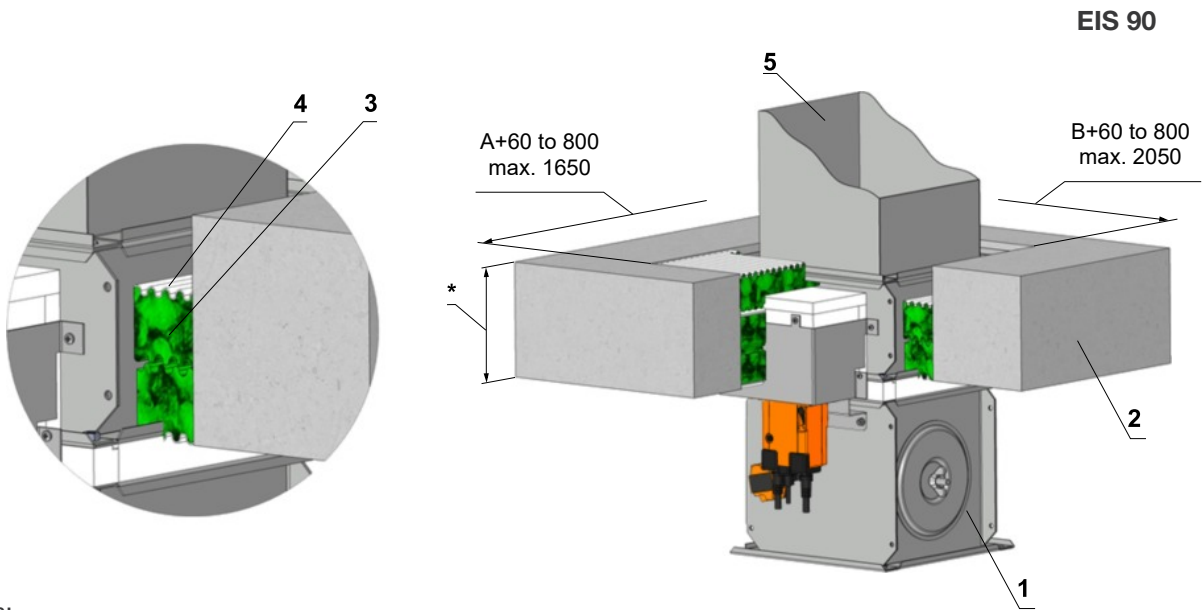

Position:

- 1 – Fire damper
- 2 – Solid ceiling construction
- 3 – Fire resistant board
- 4– Fire stop coating thickness 1 mm
- 5 – Duct

* min. 110 - Concrete/ min. 125 - Aerated concrete

Used materials - example:
 3 Hilti CFS-CT C 1S 140/50
 4 Hilti CFS-CT

5.7 Installation outside solid ceiling construction

Fig. 37 Outside solid ceiling construction - Mineral wool - mortar or gypsum

Minimum and maximum distance between the wall and fire damper when installation remote from the wall is unlimited.

EIS 90

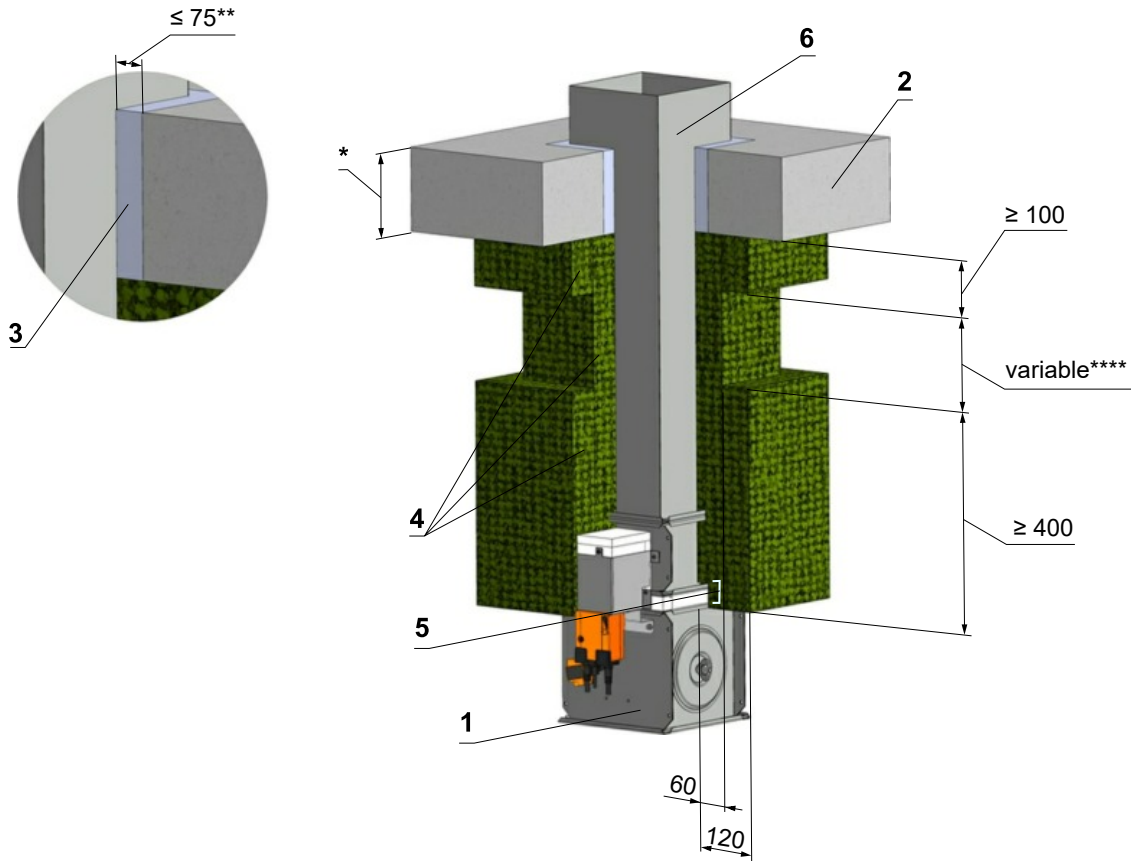

Position:

- 1 – Fire damper
- 2 – Gypsum plate
- 3 – Mineral wool (type depending on the type of construction)
- 4 – Mineral stone wool min. density 140 kg/m³
- 5 – Fire protection mastic min. thickness 1 mm
- 6 – Cement lime plate min. thickness 15 mm (min. density 870 kg/m³)
- 7 – Stone wool bound with use of an organic resin with crushed stone as a refrigerant, min. density 300 kg/m³ and min. thickness 60 mm
- 8 – Profil U25x40x25 ****
- 9 – Duct

- * min. 110 - Concrete/ min. 125 - Aerated concrete
- ** Around the perimeter

Used materials - example:***

- 4 Rockwool Wired Mat 105 th. 60 mm

*** Stuffing box, fire protection mastic, cement lime plate and insulation materials can be replaced by another approved fire sealing system for damper installation with equivalent material properties.

**** Depends on the distance of the flap from the construction, when the maximum distance from the construct is not limited and according to EN 15882-2 must use the required number of hinges according to EN 13366-1:2014.

***** Installation of profile U25x40x25 see Fig.57.

The duct at point of penetration does not have to be anchored to the fire wall construction, see chapter 6.

5.8 VRM-Q reinforcing frame

For dampers with $A \geq 800$ and damper placement outside wall construction is necessary to use reinforcement VRM-Q.

Fig. 38 Fixing of reinforcement damper to body

Important: For lower fire resistance than EI90 the reinforcement VRM-Q is not necessary!!!

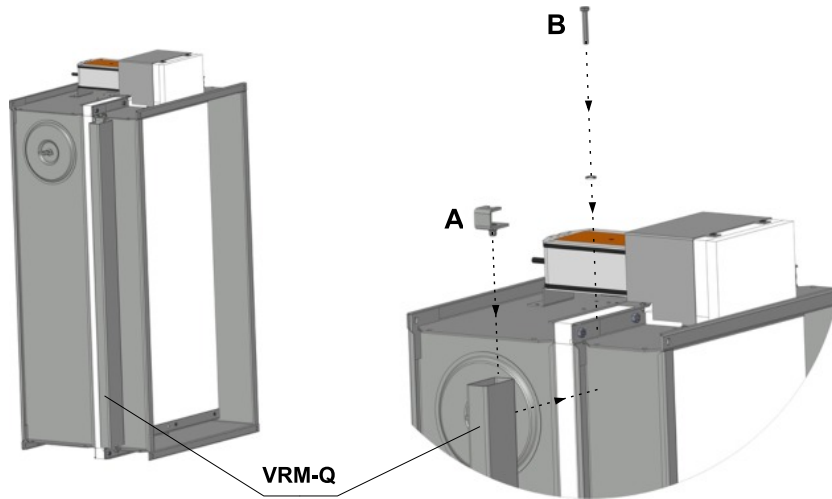

1. Insert part A into reinforcement VRM-Q
2. Set up nut of the part A under correct hole
3. Lock screw B
4. It has to be done on each side of VRM-Q

Fig. 39 Installation procedure

EIS 90
EIS 120

1) Cut the groove for profil U25x40x25

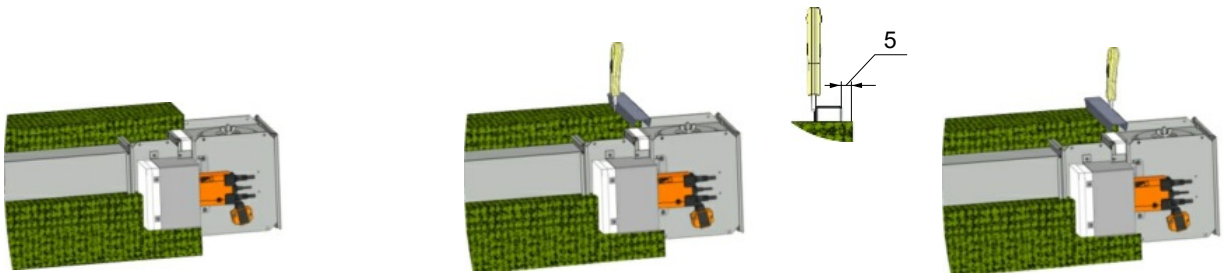

2) Insert profile into groove

3) Fix profile

4) Fix second layer of insulation

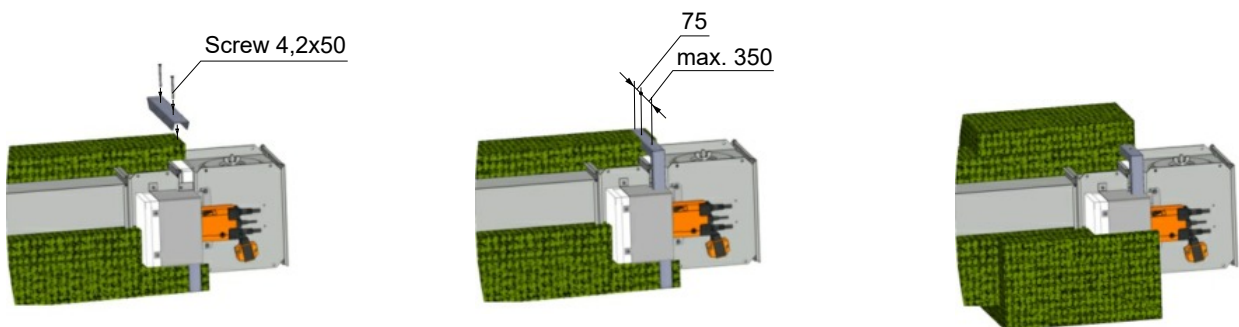

Installation details see chapter 6.

6. Suspension systems

6.1 Mounting to the ceiling wall

Fig. 40

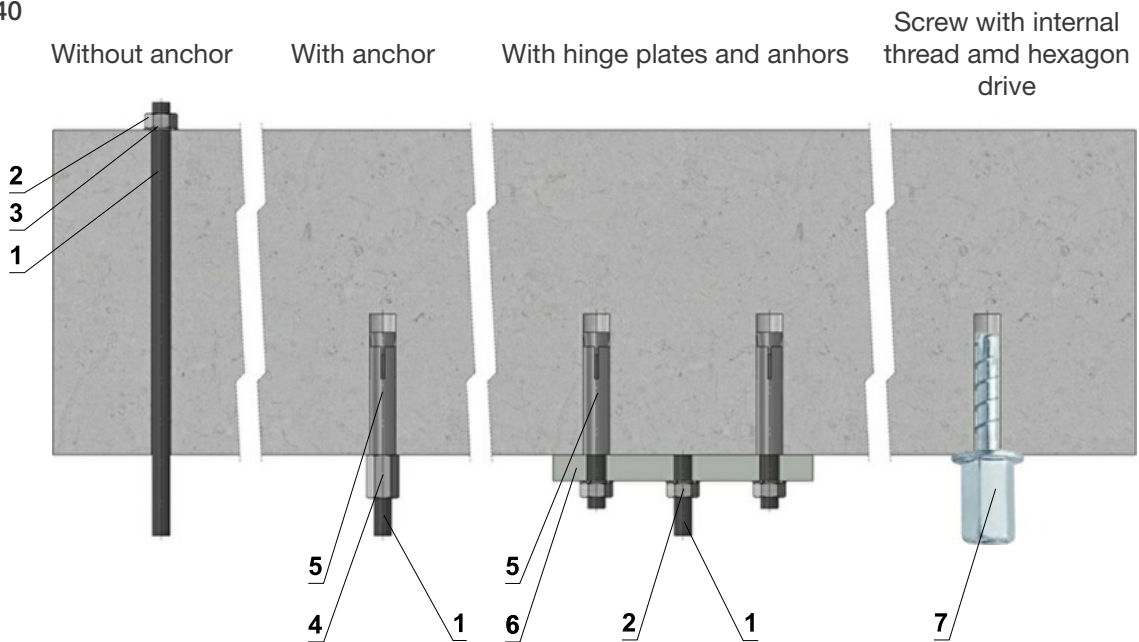

Hinge plates

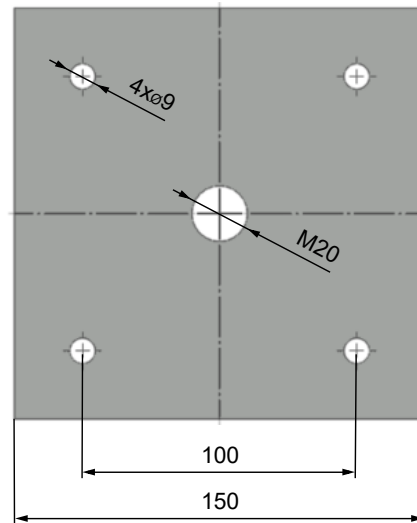
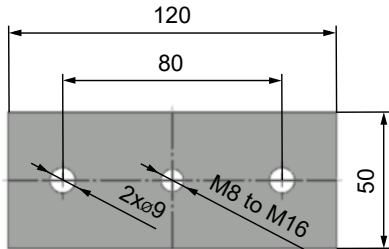

Screw with internal and hexagon drive

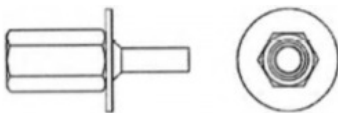

Position:

- 1 – Threaded rod M8 – M20
- 2 – Nut
- 3 – Washer
- 4 – Coupling Nut
- 5 – Anchor
- 6 – Hinge plate - min. thickness 10 mm
- 7 – Concrete screw tested for fire resistance R30-R90, max. Tension up to 0.75 KN (length 35 mm)

Load capacities of threaded hanger rods F (N) at the required fire resistance 90 minutes

Size	A _s (mm ²)	Weight G (kg)	
		for 1 piece	for 1 pair
M8	36,6	22	44
M10	58	35	70
M12	84,3	52	104
M14	115	70	140
M16	157	96	192
M18	192	117	234
M20	245	150	300

6.2 Horizontal installation

Damper assembly procedures must be done so as all load transfer from the fire separating constructions to the damper body is absolutely excluded. Back-to-back air-conditioning piping must be hung or supported so as all load transfer from the back-to-back piping to the damper is absolutely excluded.

On Fig. 41 is typical mounting situation as an example.

Threaded rods longer than 1,5 m require fire-resistant insulation.

Threaded rod fixing to the ceiling construction - see fig. 40.

Fig. 41 Suspension - horizontal duct (soft padding - mineral wool + fire boards)

EIS 90

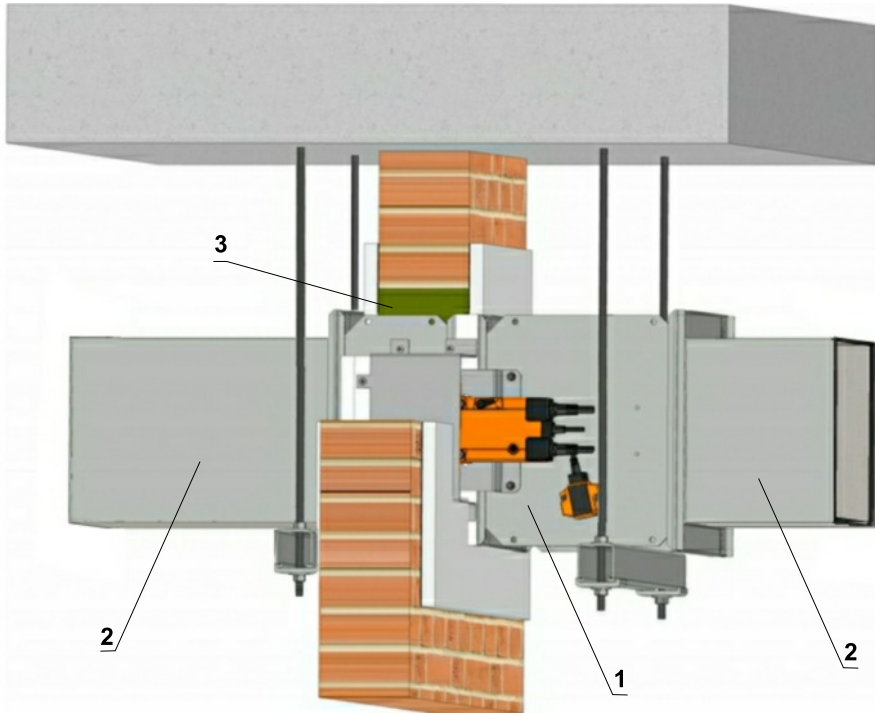

Position:

- 1 – Fire damper
- 2 – Duct
- 3 – Mineral wool
- 4 – Threaded rod
- 5 – Mounting rail
- 6 – Nut
- 7 – U - Washer
- 8 – Washer

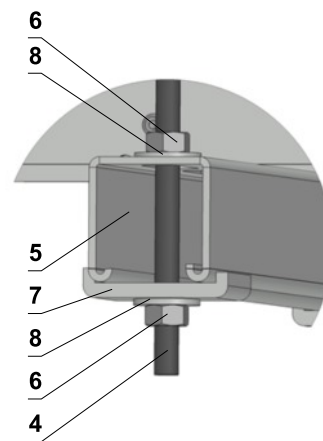

Examples of using materials: HILTI, SILKA, MÜPRO etc.

6.3 Vertical installation

The damper must not be suspended or anchored. The duct must be anchored after national rules, like in fig. 42 - as an example. It can be suspended by using threaded rods and a mounting profiles. Load the suspension system depend on weight of the fire damper.

Damper can be suspended from the ceiling construction or supported above the ceiling construction.

Damper assembly procedures must be done so as all load transfer from the fire separating constructions to the damper body is absolutely excluded. Back-to-back air-conditioning piping must be hung or supported so as all load transfer from the back-to-back piping to the damper is absolutely excluded.

Threaded rods longer than 1,5 m require fire-resistant insulation.

Threaded rod fixing to the ceiling construction - see fig. 40.

Fig. 42 Suspension - vertical duct

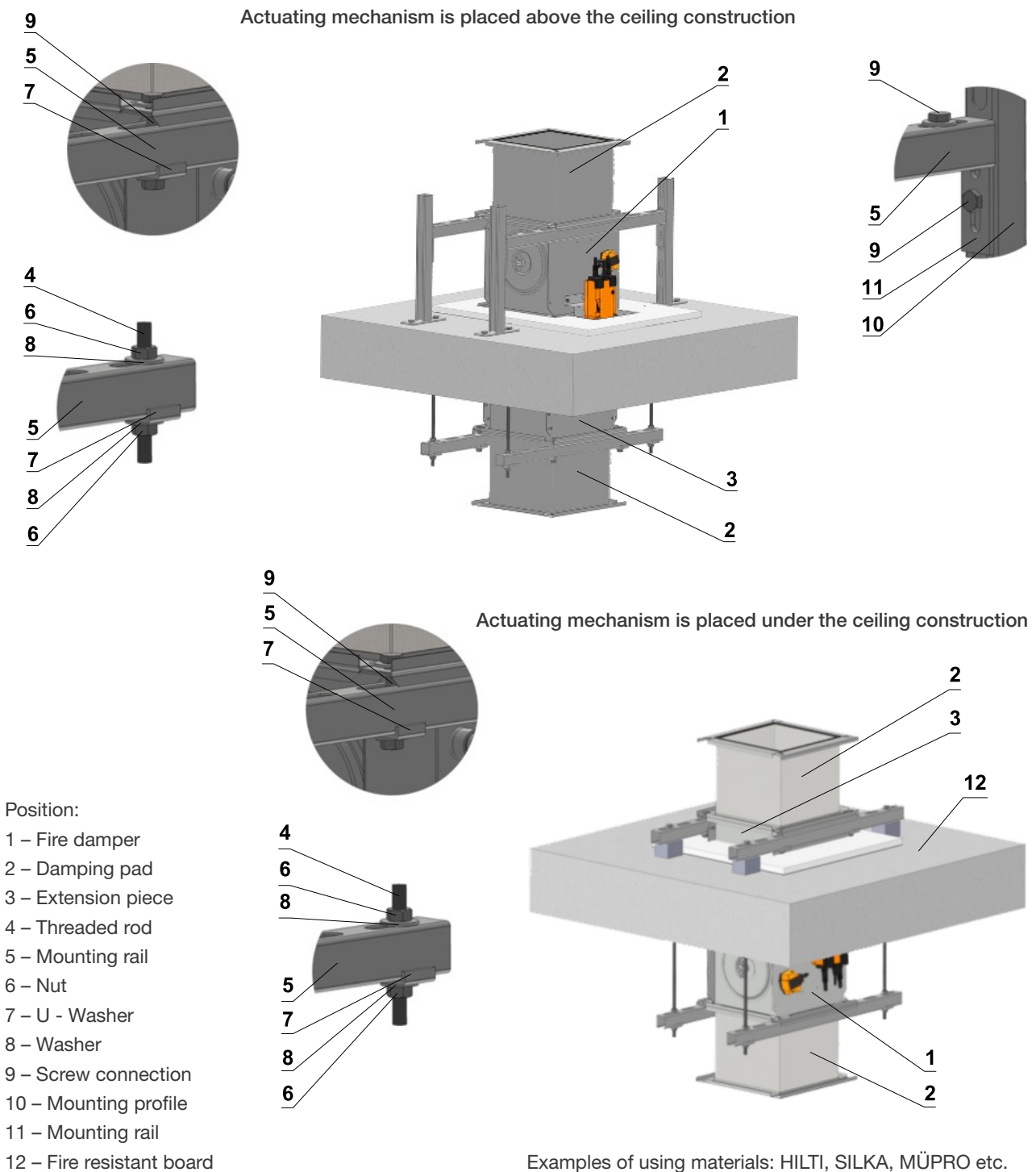

6.4 Rectangular fire damper suspension remote from the wall - horizontal installation

Fire dampers installed remote from the wall must be suspended.

The duct must be suspended on both sides of damper after national rules.

Duct between fire damper and fire separating construction must be suspended by using threaded rods and mounting profiles, or another anchoring system according national standards. Load the suspension system depend on weight of the fire damper and duct system.

Max. length between two suspension systems is 1500 mm.

Damper assembly procedures must be done so as all load transfer from the fire separating constructions to the damper body is absolutely excluded. Back-to-back air-conditioning piping must be hung or supported so as all load transfer from the back-to-back piping to the damper is absolutely excluded.

Threaded rods longer than 1,5 m require fire-resistant insulation.

If the threaded rod is located inside the duct insulation, distance between threaded rod and duct is max 30 mm. If the treaded rod is located outside the duct isolation, distance between threaded rod and isolation is max. 40 mm. Thickness of the insulation under mounting profile must be min. 30 mm.

Threaded rod fixing to the ceiling construction - see fig. 40

The insulation boards are fastened to the duct.

For more information see documentation of insulation manufacturer.

Fig. 43 Suspension remote from the wall - horizontal installation

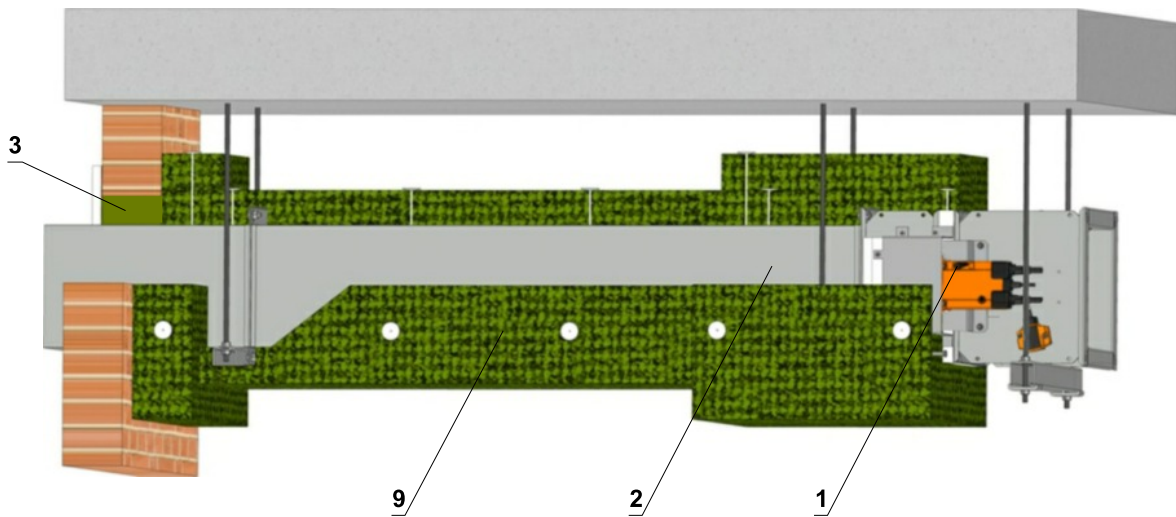

Insulation layers on the duct

Position:

- 1 – Fire damper
- 2 – Duct
- 3 – Soft padding (stone wool + fire board)
- 4 – Threaded rod
- 5 – Mounting rail
- 6 – Nut
- 7 – Washer
- 8 – Weld pin
- 9 – Insulation*

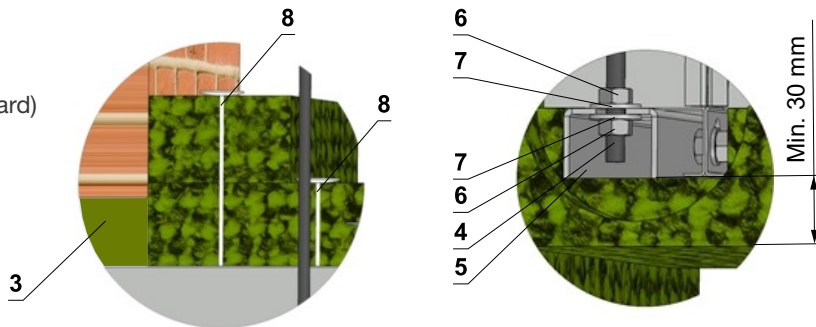

*Fixing the insulation to duct acc. to fire insulation supplier's instructions.

Technical data

7. Pressure loss

7.1 Pressure loss calculator

$$\Delta p = \xi * \rho * (w^2 / 2)$$

- Δp** - pressure loss (Pa)
- ξ** - coefficient of local pressure loss for the nominal damper section (see Tab. 7.2.1.)
- ρ** - air density (kg.m⁻³)
- w** - air flow speed in nominal damper section (m.s⁻¹)

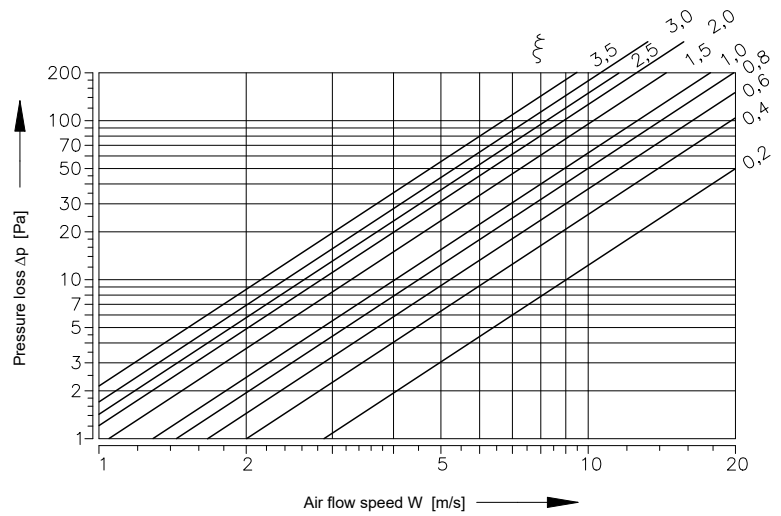

Determination of pressure loss by using diagram ρ=1,2 kg/m³

7.2 Coefficient of local pressure loss ξ (-)

Tab 7.2.1.

A	B										
	180	200	225	250	280	300	315	355	400	450	500
180	1,849	1,476	1,210	0,983	0,888	0,823	0,703	0,608	0,535	0,478	0,437
200	1,737	1,385	1,095	0,921	0,862	0,782	0,658	0,569	0,500	0,446	0,407
225	1,678	1,333	0,995	0,887	0,832	0,754	0,638	0,545	0,479	0,430	0,393
250	1,613	1,286	0,978	0,859	0,805	0,722	0,613	0,524	0,462	0,414	0,381
280	1,538	1,218	0,954	0,814	0,768	0,682	0,583	0,499	0,438	0,395	0,358
300	1,482	1,178	0,926	0,772	0,722	0,642	0,549	0,475	0,422	0,372	0,342
315	1,415	1,124	0,894	0,743	0,682	0,598	0,528	0,456	0,400	0,356	0,325
355	1,359	1,079	0,852	0,713	0,635	0,573	0,506	0,436	0,383	0,341	0,311
400	1,312	1,041	0,811	0,687	0,618	0,562	0,487	0,420	0,368	0,328	0,299
450	1,271	1,009	0,798	0,665	0,602	0,533	0,471	0,406	0,356	0,317	0,289
500	1,240	0,983	0,773	0,648	0,592	0,526	0,459	0,395	0,346	0,308	0,281
550	1,225	0,971	0,752	0,638	0,586	0,522	0,451	0,389	0,341	0,306	0,278
560	1,211	0,960	0,744	0,632	0,572	0,519	0,447	0,385	0,337	0,300	0,274
600	1,198	0,945	0,738	0,626	0,568	0,507	0,441	0,381	0,334	0,297	0,270
630	1,184	0,938	0,728	0,617	0,565	0,493	0,437	0,376	0,329	0,293	0,267
650	1,173	0,928	0,711	0,610	0,544	0,490	0,431	0,371	0,324	0,289	0,266
700	1,165	0,922	0,705	0,609	0,539	0,489	0,429	0,369	0,323	0,288	0,263
710	1,160	0,919	0,697	0,604	0,535	0,488	0,427	0,368	0,322	0,287	0,261
750	1,150	0,911	0,691	0,600	0,530	0,482	0,422	0,363	0,318	0,284	0,258
800	1,140	0,903	0,686	0,593	0,523	0,475	0,419	0,361	0,316	0,281	0,256
900	1,122	0,888	0,674	0,583	0,517	0,467	0,412	0,355	0,310	0,276	0,252
1000	1,108	0,877	0,666	0,576	0,509	0,453	0,407	0,350	0,306	0,273	0,248
1100	1,095	0,867	0,657	0,569	0,498	0,443	0,402	0,345	0,302	0,269	0,245
1250	1,084	0,857	0,643	0,562	0,486	0,438	0,397	0,342	0,299	0,266	0,242
1400	1,073	0,849	0,632	0,557	0,478	0,436	0,393	0,338	0,296	0,263	0,240
1500	1,067	0,844	0,628	0,554	0,469	0,429	0,391	0,336	0,294	0,262	0,238
1600	1,062	0,840	0,610	0,551	0,450	0,420	0,389	0,334	0,293	0,260	0,237

A	B										
	550	560	600	630	650	700	710	750	800	900	1000
180	0,418	0,400	0,378	0,369	0,352	0,349	0,343	0,331	0,322	0,304	0,291
200	0,389	0,373	0,356	0,344	0,332	0,325	0,320	0,309	0,300	0,284	0,271
225	0,375	0,361	0,342	0,333	0,319	0,313	0,309	0,302	0,292	0,272	0,262
250	0,362	0,345	0,331	0,321	0,308	0,302	0,297	0,291	0,281	0,263	0,253
280	0,342	0,325	0,312	0,302	0,291	0,288	0,283	0,271	0,267	0,249	0,241
300	0,321	0,312	0,296	0,287	0,279	0,273	0,269	0,256	0,251	0,236	0,228
315	0,305	0,297	0,282	0,274	0,267	0,259	0,254	0,246	0,238	0,225	0,215
355	0,296	0,284	0,271	0,262	0,251	0,248	0,243	0,234	0,228	0,215	0,205
400	0,281	0,273	0,265	0,252	0,243	0,237	0,234	0,226	0,219	0,207	0,197
450	0,271	0,264	0,255	0,243	0,237	0,231	0,226	0,219	0,211	0,199	0,190
500	0,269	0,257	0,244	0,236	0,228	0,223	0,219	0,212	0,205	0,194	0,185
550	0,262	0,254	0,239	0,225	0,217	0,211	0,208	0,209	0,202	0,191	0,182
560	0,259	0,250	0,231	0,230	0,221	0,210	0,208	0,206	0,200	0,189	0,180
600	0,256	0,248	0,229	0,228	0,218	0,209	0,207	0,202	0,197	0,186	0,178
630	0,253	0,244	0,228	0,225	0,215	0,209	0,207	0,199	0,195	0,184	0,176
650	0,248	0,242	0,226	0,222	0,213	0,208	0,206	0,197	0,193	0,182	0,174
700	0,244	0,241	0,225	0,221	0,212	0,207	0,205	0,196	0,192	0,181	0,173
710	0,242	0,239	0,224	0,220	0,211	0,205	0,204	0,195	0,191	0,180	0,172
750	0,240	0,236	0,220	0,218	0,209	0,203	0,202	0,194	0,189	0,178	0,170
800	0,239	0,234	0,217	0,215	0,206	0,201	0,200	0,192	0,187	0,176	0,168
900	0,234	0,230	0,215	0,212	0,200	0,198	0,196	0,189	0,184	0,173	0,165
1000	0,231	0,227	0,211	0,209	0,198	0,195	0,193	0,185	0,181	0,171	0,163
1100	0,229	0,224	0,208	0,206	0,196	0,194	0,191	0,182	0,179	0,168	0,161
1250	0,224	0,221	0,205	0,203	0,192	0,191	0,189	0,180	0,176	0,166	0,159
1400	0,221	0,219	0,203	0,201	0,189	0,188	0,187	0,178	0,175	0,165	0,157
1500	0,220	0,218	0,201	0,200	0,187	0,186	0,185	0,176	0,174	0,164	0,156
1600	0,220	0,216	0,200	0,199	0,187	0,186	0,185	0,175	0,173	0,163	0,155

8. Noise data

8.1 Level of acoustic output corrected with filter A

$$L_{WA} = L_{W1} + 10 \log(S) + K_A$$

- L_{WA} [dB(A)] level of acoustic output corrected with filter A
- L_{W1} [dB] level of acoustic output LW1 related to the 1 m² section (see Tab. 8.3.1.)
- S [m²] duct cross section
- K_A [dB] correction to the weight filter A (viz Tab. 8.3.2.)

8.2 Level of acoustic output in octave ranges

$$L_{Woct} = L_{W1} + 10 \log(S) + L_{rel}$$

- L_{Woct} [dB] spectrum of acoustic output in octave range
- L_{W1} [dB] level of acoustic output LW1 related to the 1 m² section (see Tab. 8.3.1.)
- S [m²] duct cross section
- L_{rel} [dB] relative level expressing the shape of the spectrum (see Tab. 8.3.3.)

8.3 Table of acoustics values

Tab 8.3.1. Level of acoustic output LW1[dB] related to the 1 m² section

v (m/s)	(-) ξ														
	0,2	0,3	0,4	0,5	0,6	0,7	0,8	0,9	1,0	1,5	2,0	2,5	3,0	4,0	5,0
2	15,5	18,7	20,9	22,6	24	25,2	26,3	27,2	28	31,2	33,4	35,1	36,5	38,8	40,5
3	26,1	29,2	31,5	33,2	34,6	35,8	36,9	37,8	38,6	41,7	44	45,7	47,1	49,4	51,1
4	33,6	36,7	39	40,7	42,1	43,3	44,3	45,3	46,1	49,2	51,5	53,2	54,6	56,9	58,6
5	39,4	42,5	44,8	46,5	47,9	49,1	50,2	51,1	51,9	55	57,3	59	60,4	62,7	64,4
6	44,1	47,3	49,5	51,3	52,7	53,9	54,9	55,8	56,6	59,8	62	63,8	65,2	67,4	69,2
7	48,2	51,3	53,5	55,3	56,7	57,9	58,9	59,8	60,7	63,8	66,1	67,8	69,2	71,4	73,2
8	51,6	54,8	57	58,8	60,2	61,4	62,4	63,3	64,1	67,3	69,5	71,3	72,7	74,9	76,7
9	54,7	57,9	60,1	61,8	63,2	64,4	65,5	66,4	67,2	70,4	72,6	74,3	75,7	78	79,7
10	57,4	60,6	62,8	64,6	66	67,2	68,2	69,1	70	73,1	75,3	77,1	78,5	80,7	82,5
11	59,9	63,1	65,3	67,1	68,5	69,7	70,7	71,6	72,4	75,6	77,8	79,6	81	83,2	85
12	62,2	65,4	67,6	69,3	70,7	71,9	73	73,9	74,7	77,9	80,1	81,8	83,2	85,5	87,2

Tab 8.3.2. Correction to the weight filter A

w [m/s]	2	3	4	5	6	7	8	9	10	11	12
K _A [dB]	-15,0	-11,8	-9,8	-8,4	-7,3	-6,4	-5,7	-5,0	-4,5	-4,0	-3,6

Tab 8.3.3. Relative level expressing the shape of the spectrum L_{rel}

w [m/s]	f [Hz]								
	63	125	250	500	1000	2000	4000	8000	
2	-4,5	-6,9	-10,9	-16,7	-24,1	-33,2	-43,9	-56,4	
3	-3,9	-5,3	-8,4	-13,1	-19,5	-27,6	-37,4	-48,9	
4	-3,9	-4,5	-6,9	-10,9	-16,7	-24,1	-33,2	-43,9	
5	-4,0	-4,1	-5,9	-9,4	-14,6	-21,5	-30	-40,3	
6	-4,2	-3,9	-5,3	-8,4	-13,1	-19,5	-27,6	-37,4	
7	-4,5	-3,9	-4,9	-7,5	-11,9	-17,9	-25,7	-35,1	
8	-4,9	-3,9	-4,5	-6,9	-10,9	-16,7	-24,1	-33,2	
9	-5,2	-3,9	-4,3	-6,4	-10,1	-15,6	-22,7	-31,5	
10	-5,5	-4	-4,1	-5,9	-9,4	-14,6	-21,5	-30	
11	-5,9	-4,1	-4	-5,6	-8,9	-13,8	-20,4	-28,8	
12	-6,2	-4,3	-3,9	-5,3	-8,4	-13,1	-19,5	-27,6	

9. Material

9.1

Damper bodies are supplied in the design made of galvanized plate without any other surface finishing.

Damper blades are made of fire resistant asbestos free boards made of mineral fibres.

Control devices of dampers has cover from mechanically resistant and standing plastic and rest of the parts is galvanised without further surface treatment.

Springs are galvanized.

Thermal protective fuses are made of sheet brass, thickness = 0.5 mm.

Fasteners is galvanized. Fasteners is galvanized.

9.2

According to the customer's requirements, damper can be made of stainless material.

Specifications for stainless-steel models – classification of stainless steel:

- Class A2 – Food-grade stainless steel (AISI 304 – EN 17240)
- Class A4 – Chemistry-grade stainless steel (AISI 316, 316L – EN 17346, 17349)

The respective stainless steel is the material for all components present or accessing the damper interior; components outside the damper body are typically from galvanised sheet metal (fasteners for mounting the servo drive or mechanics, mechanics components except Item 4), frame components.

The following components, including the fasteners, are made from stainless steel at all times:

- 1) Damper body and all components permanently attached
- 2) Leaf holders, including pins, metal parts of leaf
- 3) Control components inside the damper (leaf angle selector, pin with lever)
- 4) Mechanical components entering the interior of damper body (lower sheet of mechanics, lock holder “1”, lock lever “2”, lock spring, 8 dia. stopper pin, mechanics pin)
- 5) Inspection hole cover including the clip and fasteners (if they are parts of the cover)
- 6) Bearing for torque transfer from the lever with pin on the angle selector at the leaf (made from AISI 440C)

The leaf of the damper is made from a single piece of homogeneous material Promatect-MST, thickness 40 mm or is composite from two piece Promatect-H, thickness 20 mm, connected with galvanised nailed “U” connectors which are sealed with Promat K84 from the outside.

Plastic, rubber and silicon components, sealants, foaming bands, glass-ceramic seals, housings, brass bearings of the leaf, servo drives, and end switches are identical for all material variants of the dampers.

The thermal link is identical for all material variants of the dampers. Upon specification by customer, the thermal link may be made from A4 from stainless steel sheet metal.

The temperature-dependent initiator of the servo drive (sensor) is modified for stainless-steel variants of the dampers; the standard galvanised screws are replaced with stainless-steel M4 screws of corresponding class the counterpart has stainless-steel riveting M4 nuts.

Some fasteners and components are available in one class of stainless steel; the type will be used in all stainless-steel variants.

The leaf in the variants for chemical environments (Class A4) is always treated with a coating of chemically resistant Promat SR.

Any other requirements for the design shall be considered atypical and shall be addressed on an individual basis.

10. Inspection, testing

The appliance is constructed and preset by the manufacturer, its operation is dependent on proper installation and adjustment.

11. Logistic terms

11.1 Transport

Dampers are transported by box freight vehicles without direct weather impact, there must not occur any sharp shocks and ambient temperature must not exceed +40°C. Dampers must be protected against mechanic damages when transported and manipulated. During transportation, the damper blade must be in the "CLOSED" position.

11.2 Storage

Dampers are stored indoor in environment without any aggressive vapours, gases or dust. Indoor temperature must be in the range from -30°C to +40°C and maximum relative humidity 95 % (avoid condensation on the damper body). Dampers must be protected against mechanic damages when transported and manipulated

12. Assembly

All effective safety standards and directives must be observed during fire damper assembly.

The damper body should not be deformed in the course of bricking in. Once the damper is built in, its blade should not grind on the damper body during opening or closing.

Fig. 44 Embedding/ fixing the damper

Protecting the damper against buckling, above all when there are big sizes of the fire dampers!

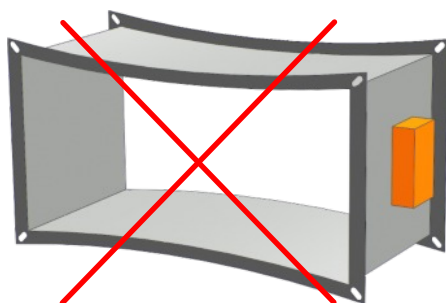

WRONG!

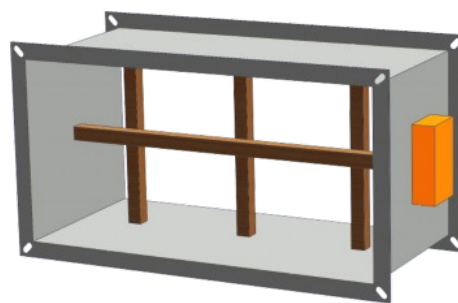

Brace with wooden blocks

Flange and screw joints must be conductively connected to protect against dangerous contact. 2 galvanized fan shape pads that are placed under the head of one screw and a fastened nut are used for conductive connection.

To ensure reliable fire damper function it is necessary to avoid blocking the closing mechanism and contact surfaces with collected dust, fibre and sticky materials and solvents.

Manual operation

Without power supply, the damper can be operated manually and fixed in any required position. Release of the locking mechanism can be achieved manually or automatically by applying the supply voltage.

13. Entry into service and revisions

13.1

Before entering the dampers into operation after assembly and after sequential revisions, checks and functionality tests of all designs including operation of the electrical components must be done. After entering into operation, these revisions must be done according to requirement set by national regulations.

In case that dampers are found unable to serve for their function for any cause, it must be clearly marked. The operator is obliged to ensure so that the damper is put into condition in which it is able to function and meanwhile he is obliged to provide the fire protection another appropriate way.

Results of regular checks, imperfections found and all-important facts connected with the damper function must be recorded in the "FIRE BOOK" and immediately reported to the operator.

13.2

Before entering the dampers into operation after their assembly and by sequential checks, the following checks must be carried out for all designs.

Visual inspection of proper damper integration, inside damper area, damper blade, contact surfaces and silicon sealing.

Inspection hole disassembly: release the covering lid by turning the wing nut and while turning the lid right or left release it from the security belt. Then tilt the lid and remove it from its original position.

13.3

Before entering the dampers with manual control into operation after their assembly and by sequential checks and following checks must be carried out.

Check of thermal protective fuse and closing mechanism.

Exert pressure on double arm initiation lever with a spring to release the control lever and check its displacement into the "CLOSED" position. Closing must be smart and the control lever must be firmly locked with a pawl. In case that the closing is not smart enough and the control lever is not locked with the pawl in the "CLOSED" position, higher pre-stretch of the closing spring must be set using a ratchet wheel.

Proper function of the thermal fuse can be checked when the fuse is removed from the starting mechanism pin. The pin must be taken out and the initiation lever must be turned over. If this is not possible, then the pin and the starting mechanism spring must be checked or the base plate must be replaced. The base plate is attached to the damper body with three M5 screws and nuts.

Displacing the damper blade into "OPEN" position is done the following way:

Release the pawl exerting pressure and return the control lever into the second outlying position where the lever is hold by the initiation lever.

In case of the flap valve with an electromagnet check the control lever displacement into the "CLOSED" position after connecting to power supply.

13.4

Before entering the dampers with actuating mechanism into operation after their assembly and by sequential checks and following checks must be carried out.

Check of blade displacement into the breakdown position "CLOSED" can be done after cutting off the actuating mechanism supply (e.g. by pressing the RESET button at the thermoelectrical starting mechanism BAT72B-S or cutting off the supply from ELECTRICAL FIRE SIGNALISATION). Check of blade displacement back into the "OPEN" position can be done after restoration of power supply (e.g. By releasing the RESET button or restoration of supply from ELECTRICAL FIRE SIGNALISATION).

13.5

Dampers could be displaced into position “CLOSED” only in case that ventilator, or Air Handling Unit is switched off. The goal is the securing of proper closing and safe function of Fire Damper in case of Fire.

14. Spare parts

Spare parts are supplied only on basis of an order.

15. Restore function of actuating mechanism after fuses initiation

If fuse Tf1 is initiated (duct outside temperature) than is necessary to change thermoelectrical starting mechanism BAT72B-S. Whereas is initiation temperature higher than actuator mechanism operating temperature +50°C, recommended actuating mechanism manufacturer make complete revision or change actuating mechanism and thermoelectrical starting mechanism.

If fuses Tf2/Tf3 are initiated (duct inside temperature) than is possible change only part ZBAT72 or ZBAT95 (according initiating temperature).

16. Ordering key

16.1 Fire damper

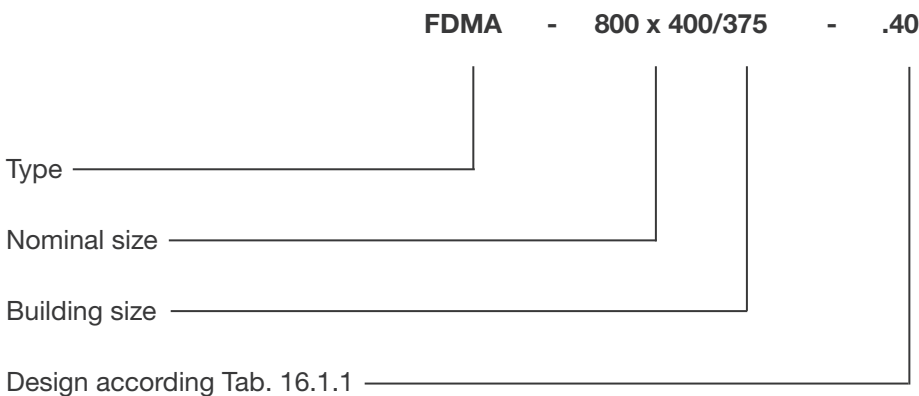

Tab 16.1.1.

Dampers design	Additional digit
Manual and thermal	.01
Manual and thermal with a terminal switch („CLOSED“)	.11
With actuating mechanism BF 230-TN (BFL, BFN 230-T)	.40
With actuating mechanism ExMax-15-BF (AC 230 V, AC/DC 24 V) with thermoelectrical starting mechanism ZONE 1,2)	.42
With actuating mechanism BF 24-TN (BFL, BFN 24-T)	.50
Manual and thermal with two terminal switches („OPEN“, „CLOSED“)	.80
Manual and thermal with two terminal switches („OPEN“, „CLOSED“) (ZONE 1,2)	.81

16.2 Reinforcement - damper placement outside wall or ceiling construction



VRM-Q - A x B

Type _____

Size _____

17. Data label

Data label is placed on the damper body.

MANDÍK ®		MANDÍK, a.s. Dobříšská 550, 267 24 Hostomice, Czech Republic	
FIRE DAMPER - FDMA			
DIMENSION:		ACTUATING SYSTEM:	
YEAR/SER.NO.:		WEIGHT (kg):	
FIRE PROTEC. CLASS: EI 90 (ve ho i ↔ o) S			
TPM 018/01	Cert. No.: 1391-CPR-2016/0158, DoP: PM/FDMA/01/20/1	EN 15650:2010	 1391



ETS NORD AS

Address: Peterburi tee 53
11415 Tallinn
Estonia

Phone: +372 680 7360
info@etsnord.ee
www.etsnord.ee

ETS NORD Finland

Address: Pakkasraitti 4
04360 Tuusula
Finland

Phone: +358 401 842 842
info@etsnord.fi
www.etsnord.fi

ETS NORD Sweden

Address: Järsjögatan 7
69235 Kumla
Sweden

Phone: +46 19 554 20 50

Address: Pinjegatan 5
21363 Malmö
Sweden

Phone: +46 40 94 68 70
info@etsnord.se
www.etsnord.se



Let's move the air together!