

# NORDcanopy

## HC Ventilation Ceiling

Modular design

---

AirGrip system

---

Laser welded structure

---

Efficient HFK cyclone filters protected as a utility model

---

Energy efficient LED lights

[www.nordcooking.com](http://www.nordcooking.com)

**HC Ventilation Ceiling**

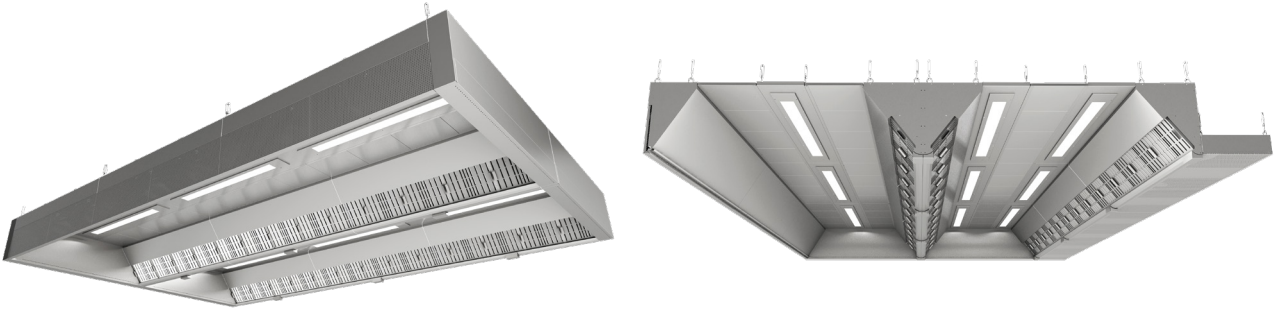

**Modules available**

**HCE**  
Exhaust Wall Module



**HCI**  
Exhaust V-module



**HCG**  
AirGrip Module



**HCH**  
Horizontal Supply Air Module



**HCV**  
Vertical Supply Air Module



**HCAH**  
Horizontal Supply Module



**HCL**  
LED Light Module



**HCF**  
Ceiling Panel



**HCM**  
Noise Absorbing Ceiling Panel



**Exhaust and Supply Corner Elements**

**HCAE**  
Inner Corner Exhaust

**22**

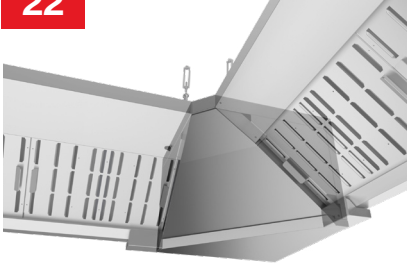

**HCAS**  
Inner Corner Supply

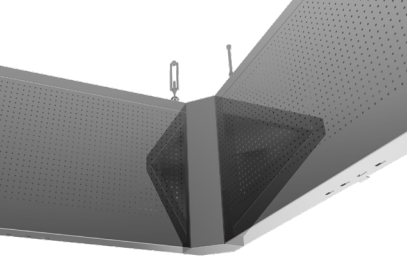

**HCAV**  
Outer Corner Supply

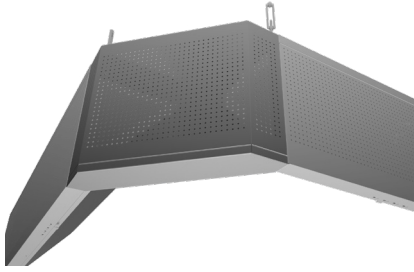

**HC Options & Accessories**

**OZ**  
Ozone Generator

**23**



**EOZ**  
External Ozone Generator



**HFK**  
Grease Filter

**26**



**FET "Helping hand"**  
Grease filter removal tool

**27**



## HC Ventilation Ceiling

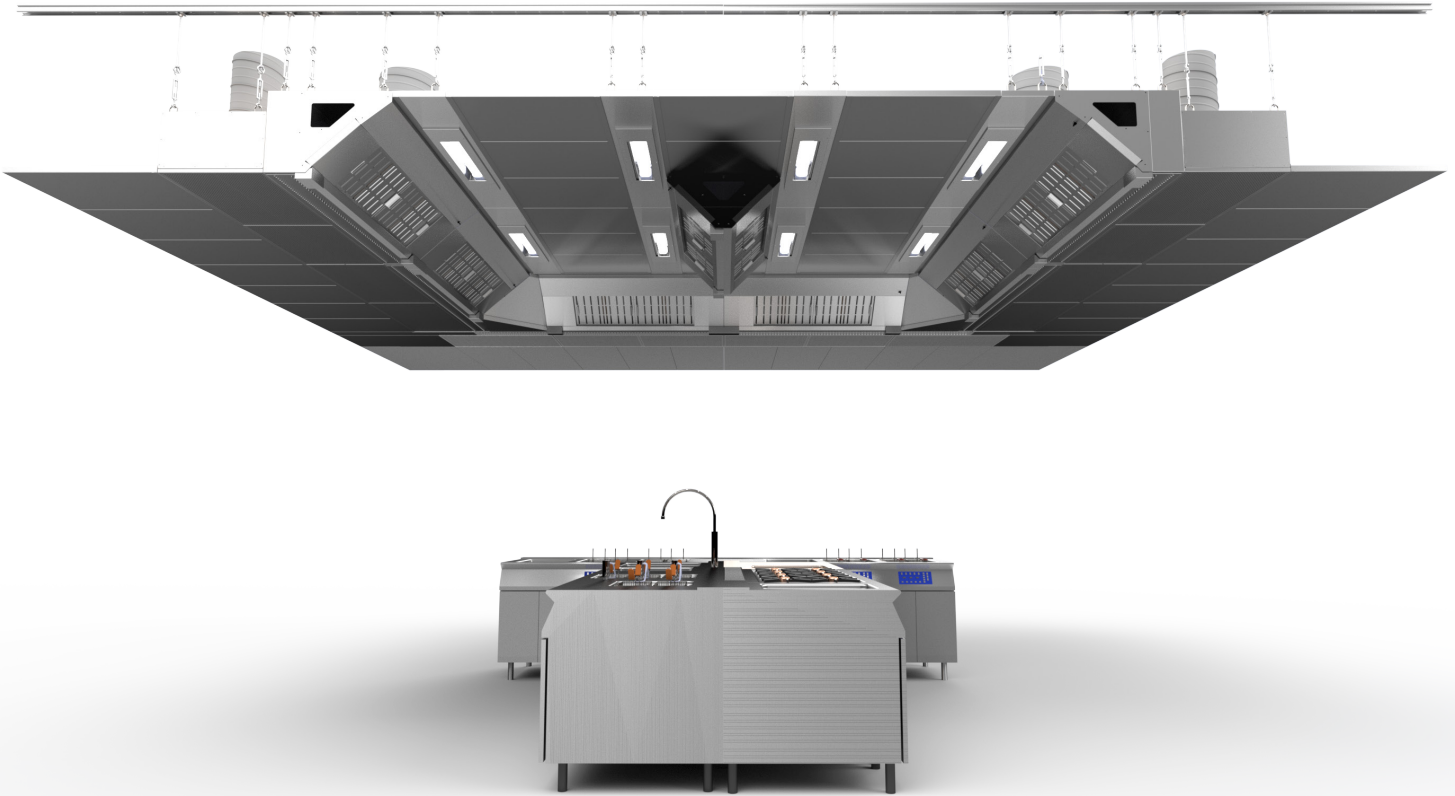

ETS NORD's ventilation ceiling system combines effective grease removal with stylish design to thoroughly clean the exhaust airstream and remove excess heat from the kitchen. We at ETS NORD know that no two projects are exactly alike. Since ETS NORD kitchen ventilation solutions are modular in their construction, each ventilation ceiling can be individually designed to meet every project requirement or technical need.

The system consists of a different broad selection of exhaust and supply modules, sound absorbing panels and LED-lighting options. In addition to mechanically separating grease with our highly efficient HFK grease filters, the ventilation ceiling can also include an intelligent ozone cleaning system to further reduce grease and odor. Ozone treatment is simply chemical oxidation, whereby grease and odor are broken down to water vapor and dry minerals, thereby providing many advantages.

NORDcanopy products are manufactured from stainless steel according to standards EN 10088- 2:2014, EN 1.4301 or AISI 304 (AISI 304, surface 2K).

- Duct connections are equipped with rubber gaskets.
- Supply air modules are heat insulated to prevent condensation of steam on the inner surface of the chamber.
- The laser welded end walls of the exhaust chamber prevent the possible leakage of grease from the inside of the chamber, thereby reducing the possibility of bacteria forming in the joints.
- Easy-to-clean surfaces.
- Access to the supply chamber and the ability to clean the supply ducts is ensured through the easy-to-remove front panels. Exhaust ducts can be easily reached and insulated via removable ceiling panels.
- Adjustable suspension hooks are included.



## HCE Exhaust Wall Module

HCE is an exhaust air module with one row of HFK grease filters for installation against walls. HCE ensures a clean, hygienic and comfortable work environment by removing pollutants, excessive heat and grease from the cooking process.

HCE exhaust module has laser welded construction.

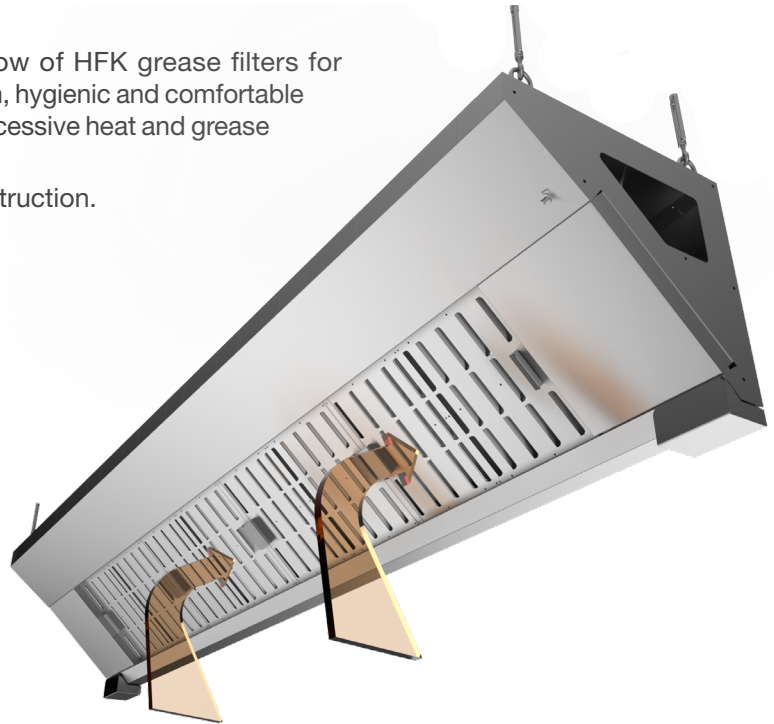

### Dimensions

#### HCE-E1

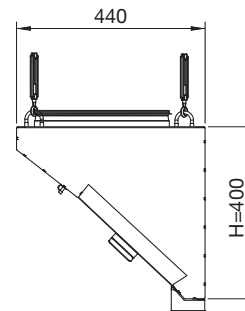

Length L	Connections	
	d, mm	E1 quantity
1000	250	1
1000	315	1
1500	250	1
1500	315	1
2000	250	2
2000	315	2
2500	315	2
2500	315	3

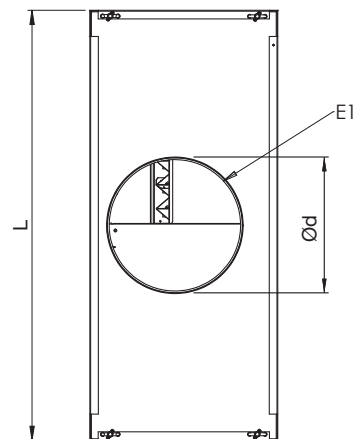

**Product marking**

**HCE - L x H - E1=XxX - HFKxX**

**Marking**

HCE - Exhaust Wall Module

**Dimensions LxH**

L - Length  
H - Height (400 mm)

**Exhaust air**

E1 - Filters in one row  
Diameter of exhaust air connection  
Quantity of exhaust air connections

**Grease filters**

HFK  
Grease filter quantity

**Example: HCE 1500x400 E1=250x1 HFKx3**

## HCI Exhaust V-module

HCI is a V-shaped exhaust air module with two rows of HFK grease filters, one on each side. HCI grease module ensures a clean, hygienic and comfortable work environment by removing pollutants, excessive heat and grease from the cooking process.

HCI exhaust module has laser welded construction.

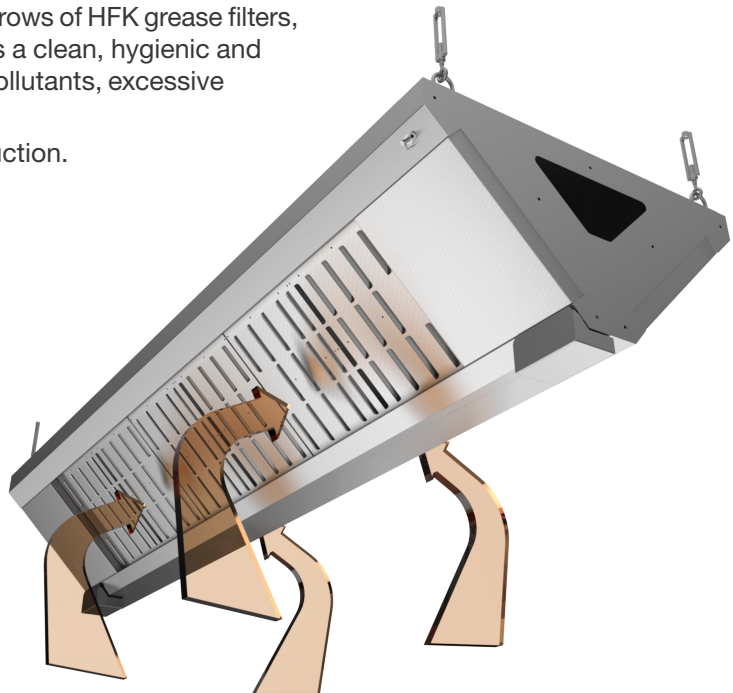

### Dimensions

#### HCI-E3

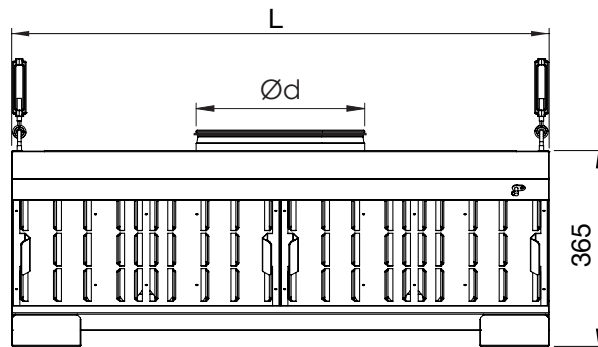
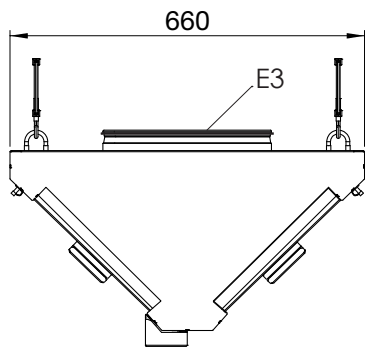

Length L	Connections	
	d, mm	Quantity
1000	315	1
1000	400	1
1500	315	2
1500	400	1
2000	315	2
2000	400	2
2500	315	3
2500	400	2



**Technical data**

**HFK - grease filter**

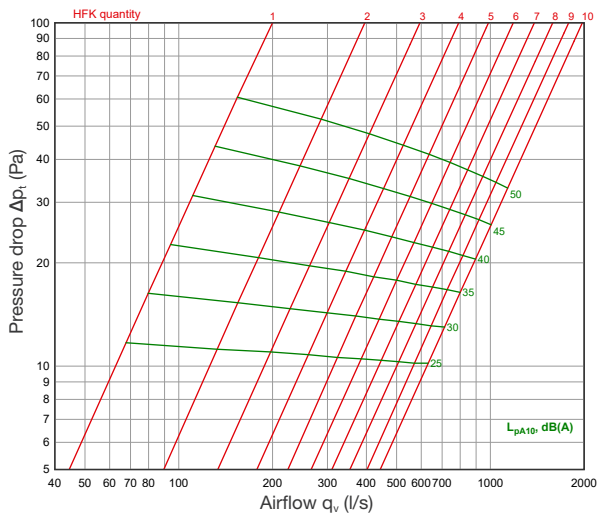

**Product marking**

**HCI - L - E3=XxX - HFKxX**

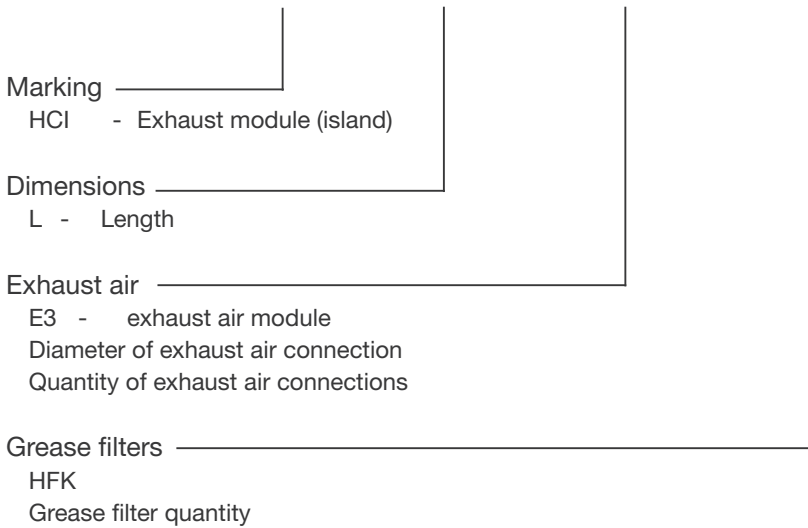

**Example: HCI 1500 E3=315x2 HFKx6**

## HCG AirGrip Module

HCG AirGrip module uses capillary action to capture and direct kitchen emissions toward the exhaust modules, much like that of an air curtain. With both vertical and horizontal airflow components, HCG significantly improves ventilation ceiling effectiveness.

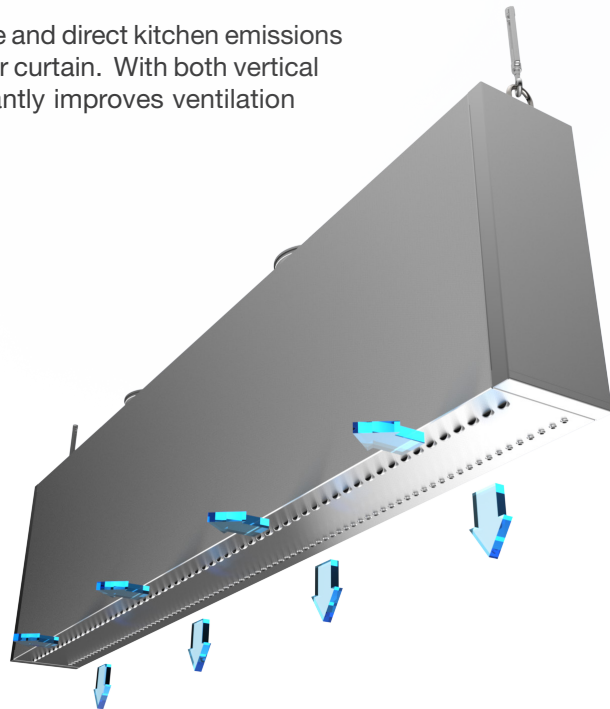

### Dimensions

Length L	Connections quantity
1000	1
1500	1
2000	2
2500	3

### Technical data

Air adjustment plate position open or closed.

HCG L=1000

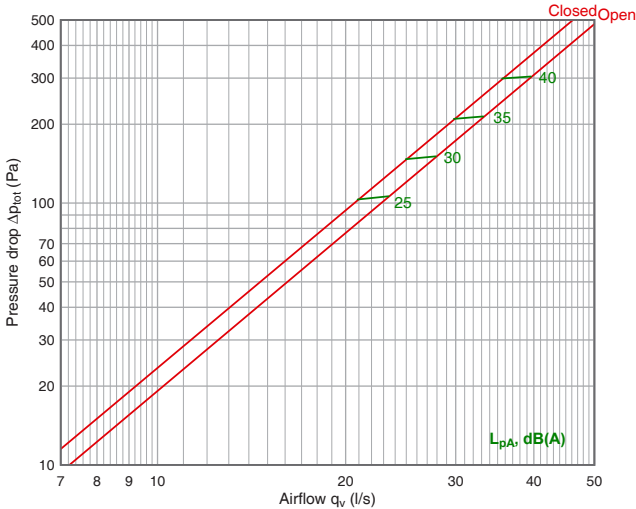

HCG L=1500

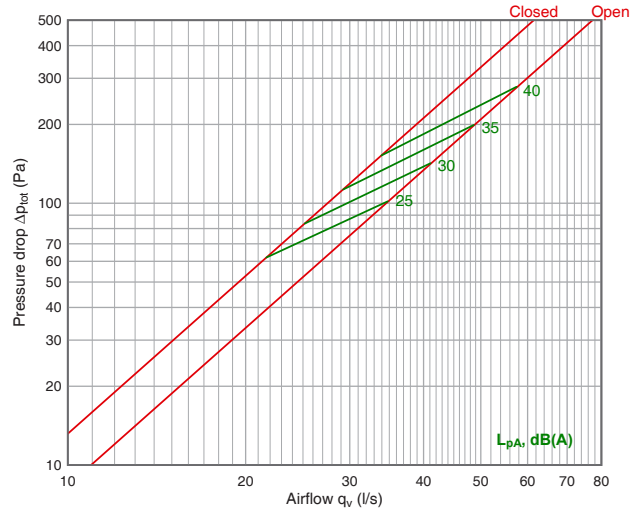

HCG L=2000

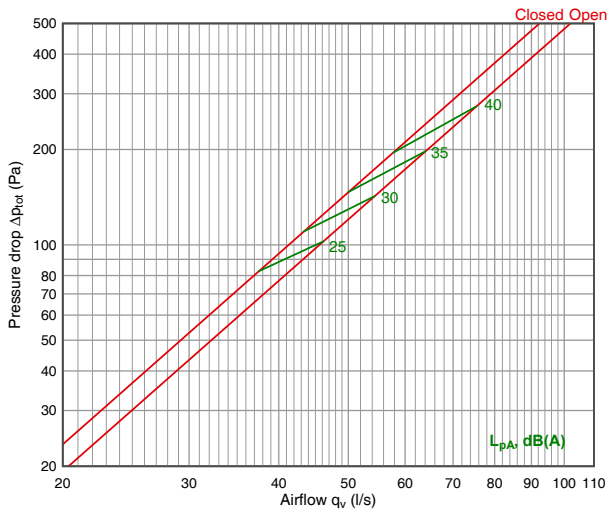

HCG L=2500

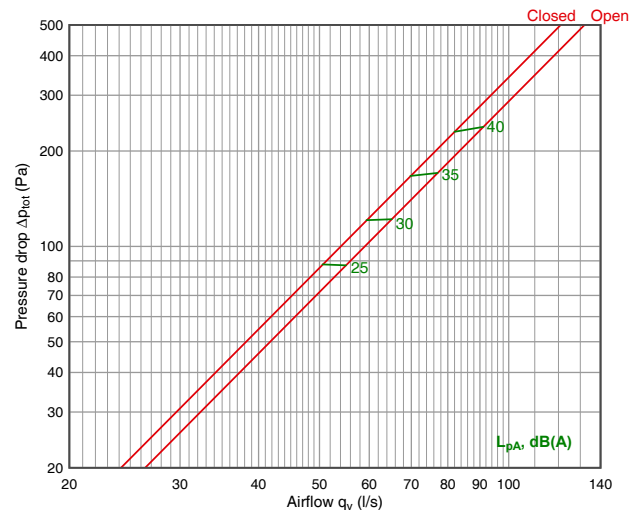

Acoustic data

Supply air	Air adjustment plate	K-factor	Correction of sound level $K_{okt}$ [dB] (Hz)							
			63	125	250	500	1000	2000	4000	8000
HCG 1000	Closed	2,34	0	-2	-1	-5	-4	-7	-12	-14
	Open	2,33	-3	-6	-6	-7	-6	-5	-8	-11
HCG 1500	Closed	3,45	0	-2	-1	-5	-4	-7	-12	-14
	Open	3,45	-3	-6	-5	-7	-6	-6	-9	-12
HCG 2000	Closed	4,67	-2	0	2	-1	-6	-13	-17	-21
	Open	4,66	-2	-6	-4	-6	-6	-6	-9	-12
HCG 2500	Closed	5,89	-2	0	2	-1	-6	-13	-17	-21
	Open	5,89	-3	-6	-5	-7	-6	-6	-9	-12

Product marking

HCG - L x H - X x X

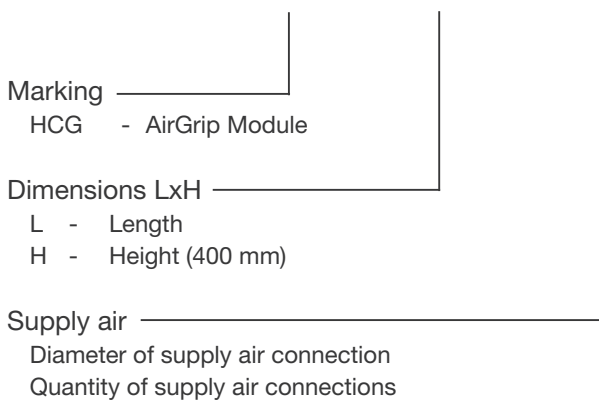

Example: HCG 1500x400 125x1



**HCH Horizontal Supply Air Module**

HCH is a horizontal supply air module, designed to supply fresh replacement air into the kitchen to provide ultimate worker comfort. Front panels are easily removed for accessing and cleaning its supply chambers and ducts.

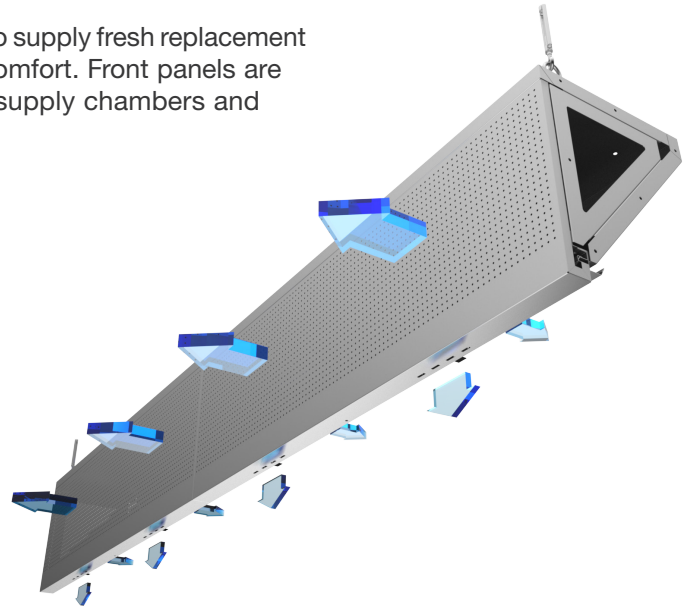

**Dimensions**

Length L	Connections quantity
1000	1 ... 2
1500	1 ... 2
2000	2 ... 3
2500	2 ... 3

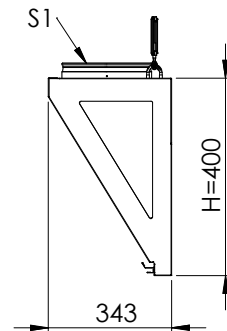
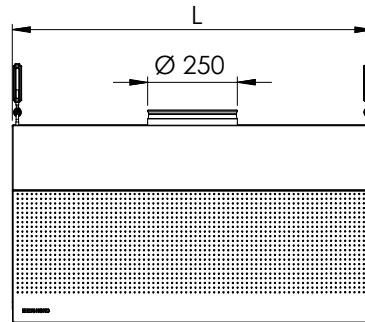

**Technical data**

The supply panels always contain the "AirGrip" air intake system.

**Supply air: SPx1**

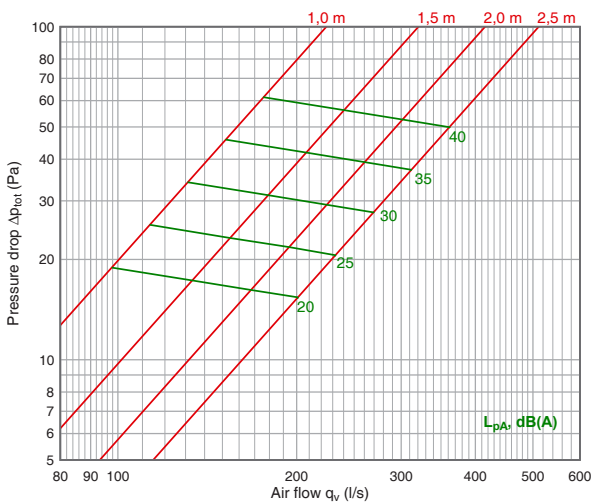

**Supply air: SPx2**

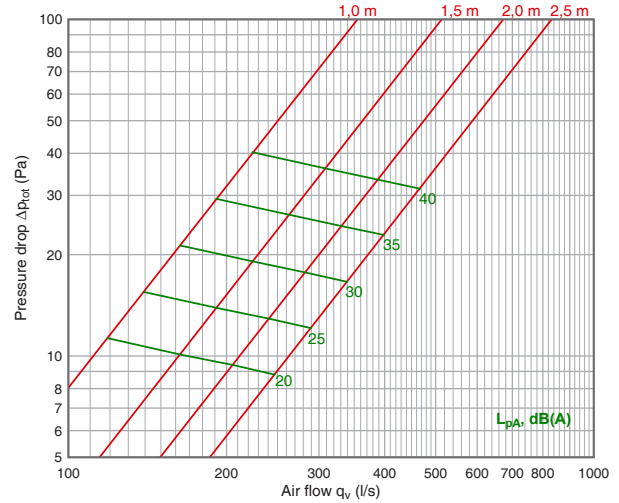

Supply air: SPx3

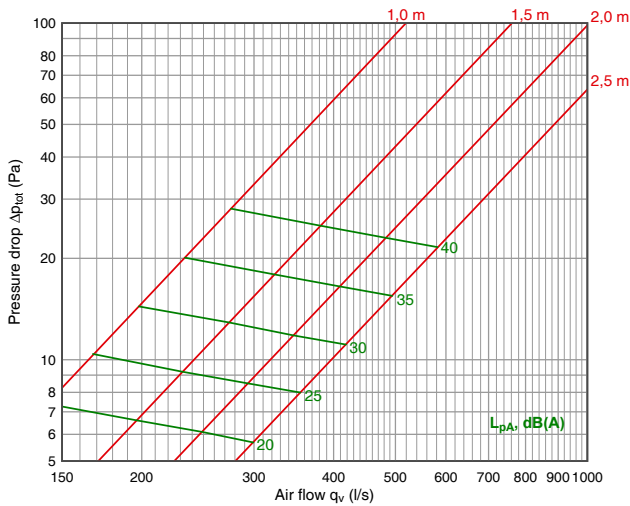

Acoustic data

$$L_w = L_{p10A} + K_{okt}$$

Supply air	Correction of sound level $K_{okt}$ (dB)							
	(Hz)							
	63	125	250	500	1000	2000	4000	8000
SPx1	-1	0	3	2	-1	-3	-11	-23
SPx2	0	1	5	4	-1	-8	-20	-27
SPx3	7	5	6	4	-2	-13	-21	-30
	$\pm 4$ dB	$\pm 4$ dB	$\pm 4$ dB	$\pm 2$ dB	$\pm 2$ dB	$\pm 2$ dB	$\pm 2$ dB	$\pm 2$ dB

Product marking

HCH - L x H - X x X - SPx1(2,3)

Marking

HCH - Supply Air Module

Dimensions LxH

L - Length (1000, 1500, 2000, 2500, mm)

H - Height (400 mm)

Supply air

Diameter of supply air connections

Quantity of supply air connections

Front panel

SPx1 - Perforation pattern 1

SPx2 - Perforation pattern 2

SPx3 - Perforation pattern 3

Example: HCH 1500x400 250x1 SPx1

## HCV Vertical Supply Air Module

HCV is a vertical supply air module, designed to supply fresh replacement air into the kitchen area to provide ultimate worker comfort. HCV can also be used for some exhaust applications as well.

Its panels can be removed for cleaning purposes and easy access to supply ducts.

- Even and draft-free air distribution in the kitchen
- Easy to clean surfaces
- Easily removable front panels
- The frame is manufactured from 1 mm stainless steel (AISI 304, surface 2K)
- Supply air duct connections are Ø 250 mm and equipped with rubber seals and integrated dampers

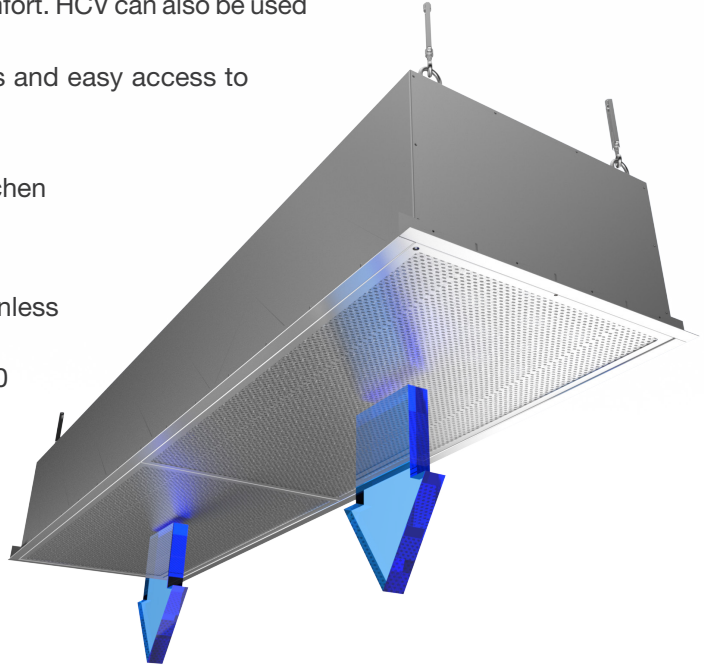

### Dimensions

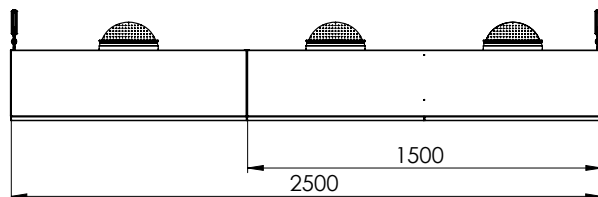
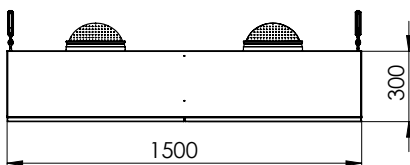
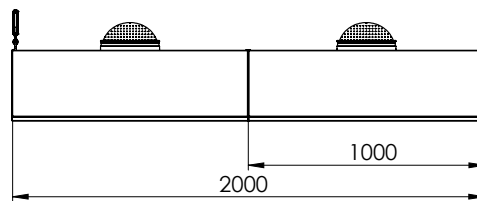
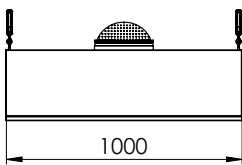
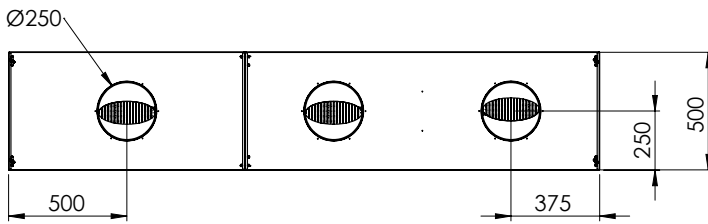

Technical data

Supply air

HCV 1000

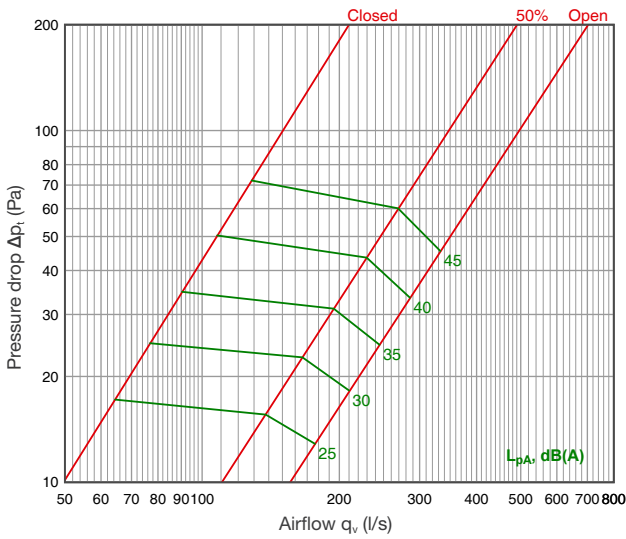

HCV 1500

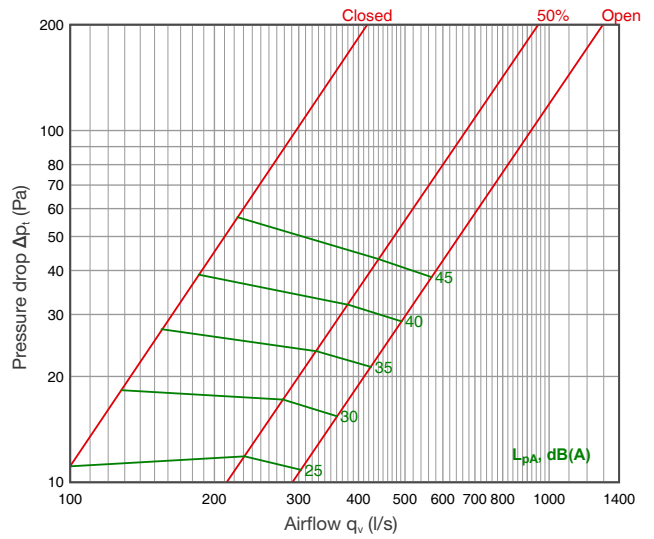

HCV 2000

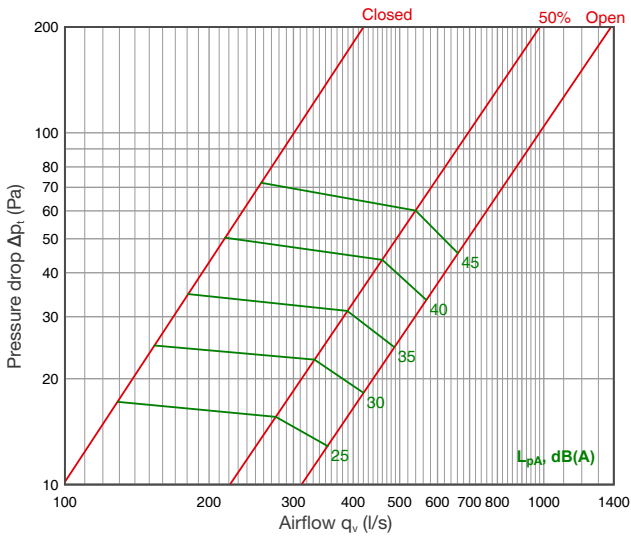

HCV 2500

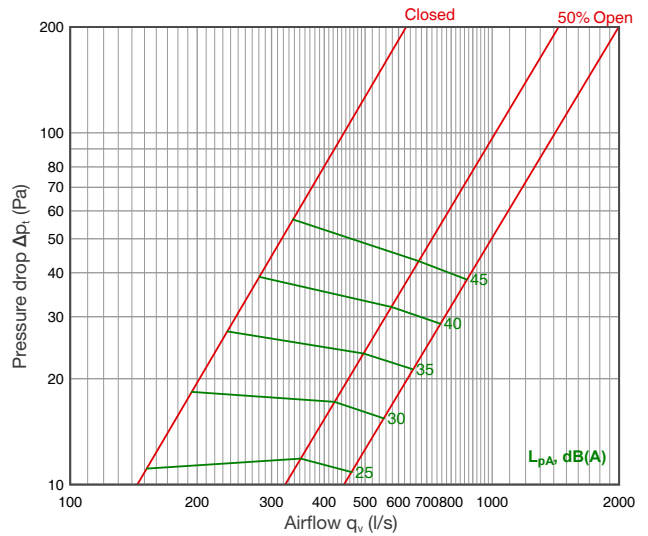

Exhaust air

HCV 1000

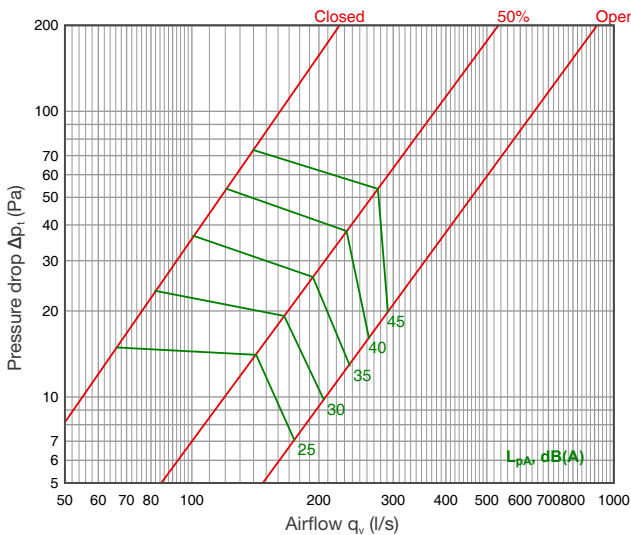

HCV 1500

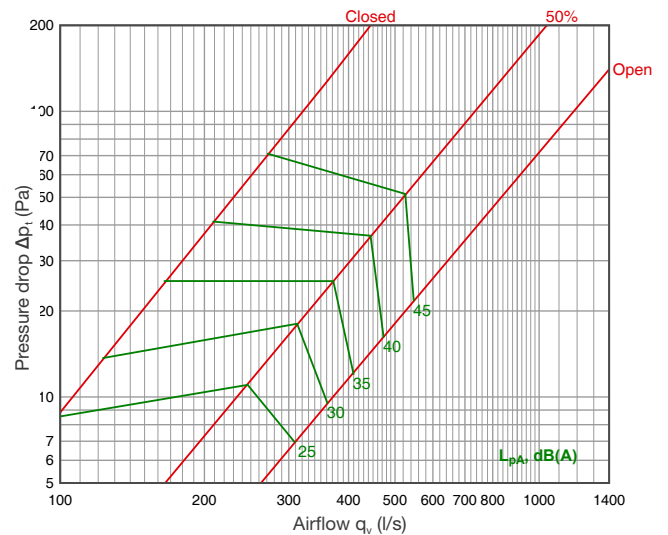

HCV 2000

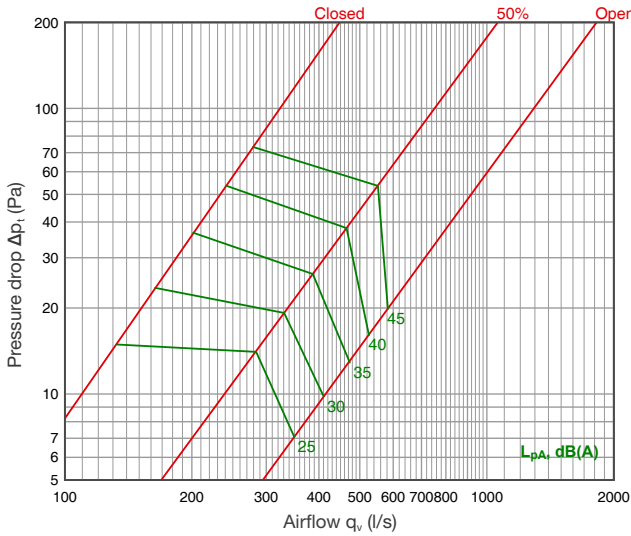

HCV 2500

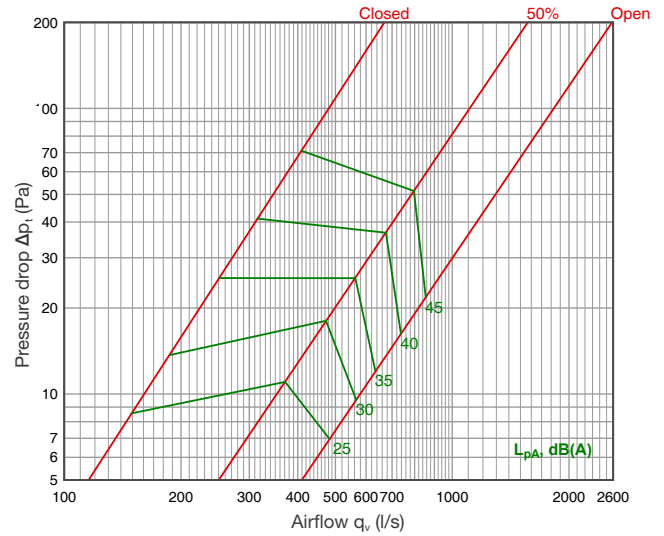

Acoustic data

Supply air,  $L_w = L_{wA} + K_{okt}$

Product	Position	Sound level correction factor $K_{okt}$ (dB)							
		Mean frequency of octave band (Hz)							
		63	125	250	500	1k	2k	4k	8k
HCV 1000	Open	-0,6	-0,9	-3,6	-6,6	-5,6	-8,5	-13,6	-15,9
	50%	-1,3	0,1	-3,0	-5,9	-6,0	-8,4	-12,6	-15,3
	Close	-11,1	-6,2	-3,8	-0,9	-8,6	-13,2	-16,6	-14,8
HCV 1500	Open	4,0	2,2	-1,3	-6,5	-6,5	-9,9	-13,6	-17,1
	50%	3,6	2,3	-1,7	-5,2	-6,4	-10,1	-12,5	-16,3
	Close	-8,3	-7,3	-4,3	-4,0	-8,4	-12,5	-16,7	-15,8
HCV 2000	Open	-12,3	3,8	-0,8	-6,4	-6,8	-10,7	-13,6	-18,2
	50%	4,4	3,8	-0,5	-4,8	-6,6	-12,3	-12,4	-17,3
	Close	-7,6	-8,4	-4,8	-7,1	-8,2	-11,7	-16,9	-17
HCV 2500	Open	-13,2	4,3	-0,2	-6,3	-6,9	-11,4	-13,6	-19,3
	50%	5,2	4,9	-0,1	-4,5	-6,8	-12,1	-12,2	-18,2
	Close	-6,7	-9,5	-5,3	-9,6	-7,9	-11,1	-17,1	-17,2

Exhaust air,  $L_w = L_{wA} + K_{okt}$

Product	Position	Sound level correction factor $K_{okt}$ (dB)							
		Mean frequency of octave band (Hz)							
		63	125	250	500	1k	2k	4k	8k
HCV 1000	Open	-11,5	-11,1	-14,2	-10,7	-5,3	-9,0	-15,1	-17,7
	50%	-4,6	-3,7	-5,7	-6,6	-6,7	-7,4	-9,3	-12,4
	Close	-11,3	-9,5	-7,7	-5,6	-8,1	-9,8	-10,7	-12,1
HCV 1500	Open	-3,9	-6,4	-10,4	-11,9	-13,2	-12,2	-15,9	-22,5
	50%	2,6	-0,3	-3,0	-6,0	-6,9	-8,9	-10,1	-13,3
	Close	-18,9	-16,1	-13	-14,3	-15,8	-16,2	-11,7	-11,1
HCV 2000	Open	0,5	-4,7	-8,4	-12,5	-14,1	-14,3	-16,2	-23,2
	50%	4,8	1,3	-1,6	-5,7	-7,2	-9,3	-11,3	-14,2
	Close	-20,4	-18,5	-15,2	-16,5	-17,2	-17,9	-12,4	-10
HCV 2500	Open	3,4	-3,4	-6,7	-12,9	-14,7	-15,1	-16,4	-24,1
	50%	6,9	3,4	-0,3	-5,3	-7,5	-9,4	-11,6	-15,1
	Close	-22,7	-19,9	-17,3	-17,6	-18,3	-18,5	-12,9	-8,9

Sound attenuation

Product	Sound attenuation $D_{\text{okt}}$ (dB)							
	63	125	250	500	1k	2k	4k	8k
HCV 1000	11	6	3	3	1	1	1	1
HCV 1500	12	7	3	4	2	1	1	2
HCV 2000	13	8	4	4	2	1	1	2
HCV 2500	14	9	4	5	3	1	1	3

Airflow pattern

HCV 1000x500, temperature difference (50% open)

From the long side

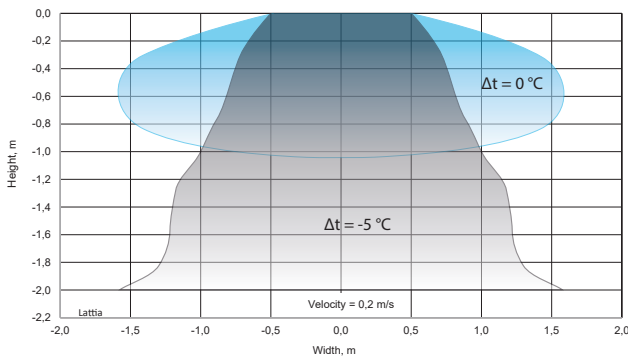

From the short side

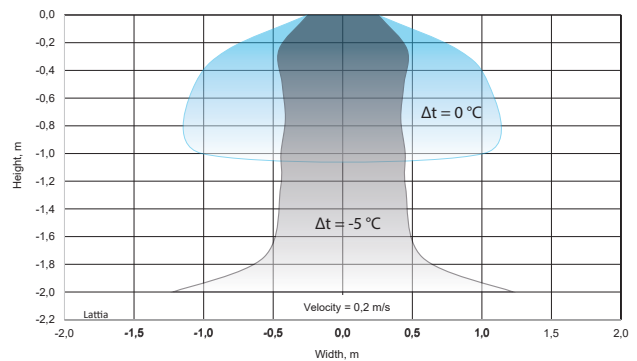

HCV 1500x500, temperature difference

From the long side

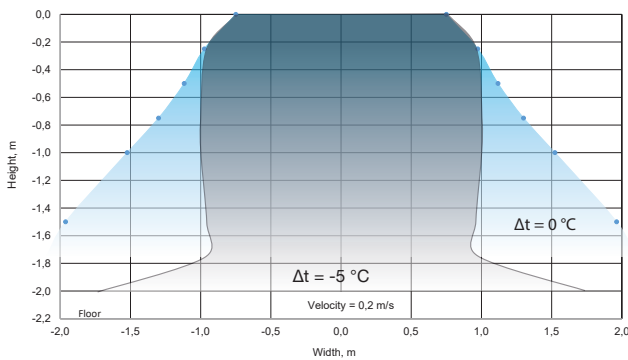

From the short side

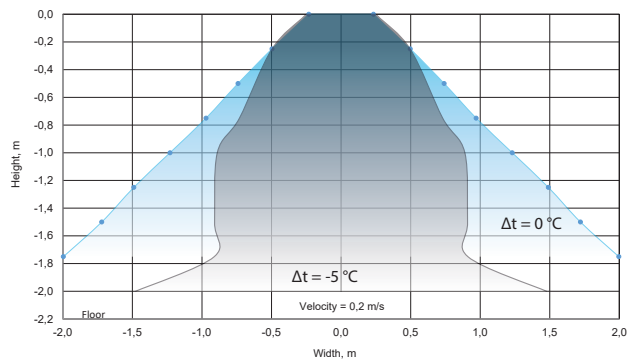

Product marking

HCV - L - X x X

Marking

HCV - Vertical Supply Air Module

Length L

1000, 1500, 2000, 2500 mm

Duct connection

Diameter of air connection

Quantity of air connections

Example: HCV 1500 250x2



## HCAH Horizontal Supply Module

HCAH is a horizontal supply air module including both vertical and horizontal "AirGrip" functionality. HCAH can furthermore be installed back-to-back with exhaust modules.

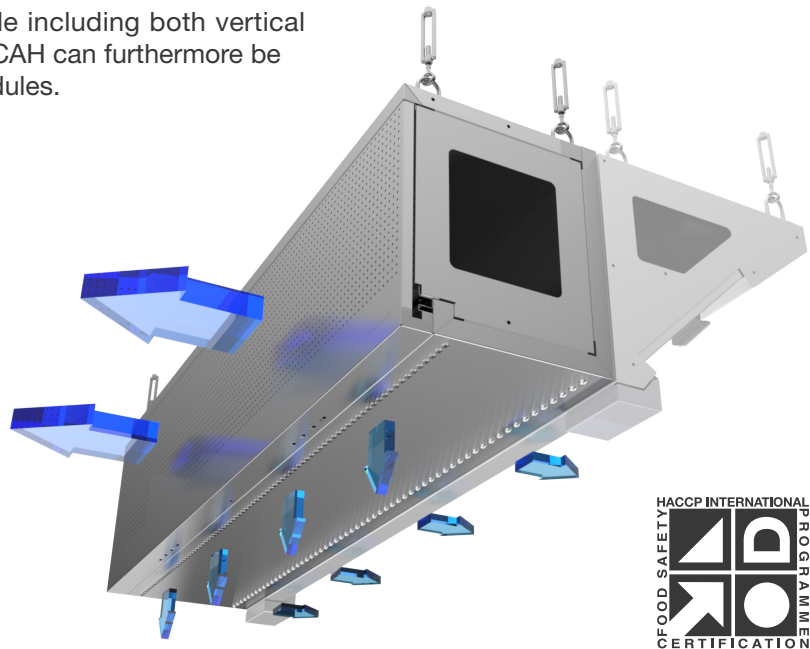

### Dimensions

Length L	Connections quantity
1000	1
1500	1
2000	2
2500	2

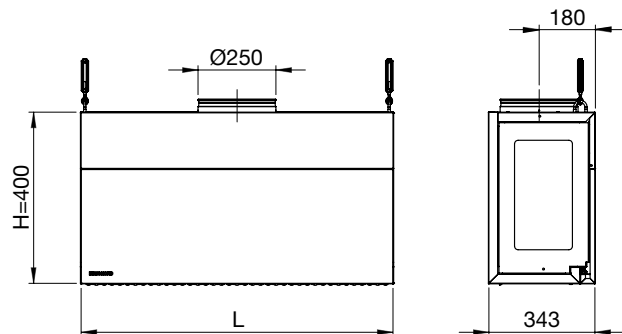

### Product marking

HCAH - L x H - X x X - SPx1(2,3)

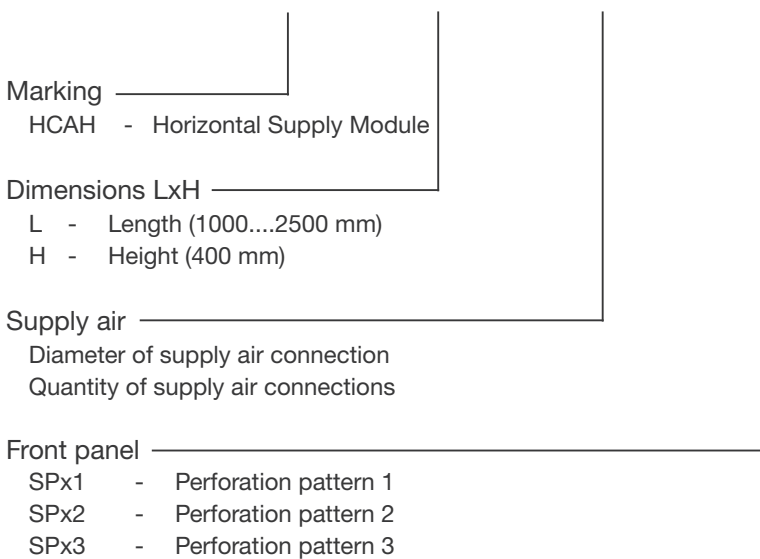

Example: HCAH 1500x400 250x1 SPx1

**HCL LED Light Module**

Professional kitchens require functional lighting to ensure that employees have a safe and effective work environment. ETS NORD kitchen ventilation ceilings use the next generation of energy-efficient recessed LED fluorescent lamps, which can save as much as 50% more energy compared to old technologies.

LED light fixtures are integrated into ceiling modules, protected by an aluminum and glass casing. The size and number of light fixtures are determined by the dimensions of the ventilation ceiling, to ensure there is enough light output for the entire workspace.



**Dimensions**

Length L	Width B	Light
1000	250-500	LED 770
1500	250-500	LED 1370
2000	250-500	LED 1670
2500	250-500	LED 1670

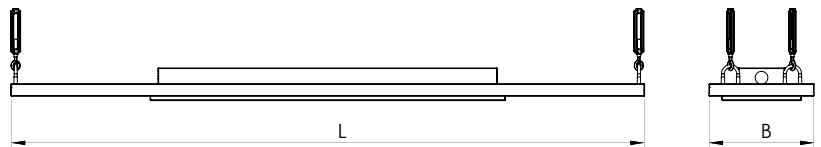

LED luminaries (standard), IP66

Luminaries	Lighting length (mm)	Energy use (W)	Light color	Color temperature (K)	Color rendering index (Ra)	Flux (lm)
LED770	769	17	840	4000	80	2250
LED1370	1350	41	840	4000	80	4900
LED1670	1669	54	840	4000	80	6800

DALI LED luminaries, IP66

Luminaries	Lighting length (mm)	Energy use (W)	Light color	Color temperature (K)	Color rendering index (Ra)	Flux (lm)
DALI750	750	14	840	4000	80	2000
DALI1350	1350	35	840	4000	80	5200
DALI1650	1650	48	840	4000	80	7150

**Product marking**

**HCL - L x B - LED/DALI**

**Marking**

HCL - LED Light Module

**Dimensions LxB**

L - Length (1000, 1500, 2000, 2500 mm)

B - Width (250-500 mm)

**Lighting**

LED770 - L=769, 17W

LED1370 - L=1369, 41W

LED1670 - L=1669, 54W

DALI750 - L=769, 14W

DALI1350 - L=1369, 35W

DALI1650 - L=1669, 48W

**Example: HCL 1500x250 LED1370**

**HCF Ceiling Panel**

HCF is a ceiling panel that fills in the areas without exhaust or supply modules.

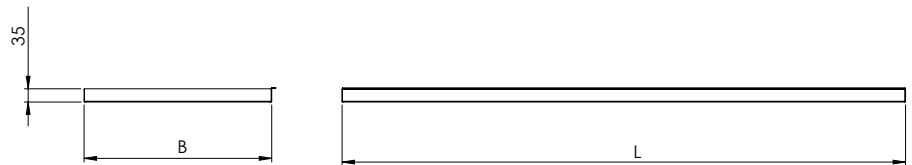
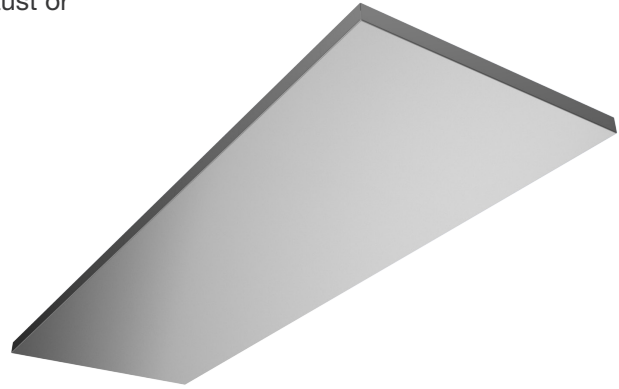

**Product marking**

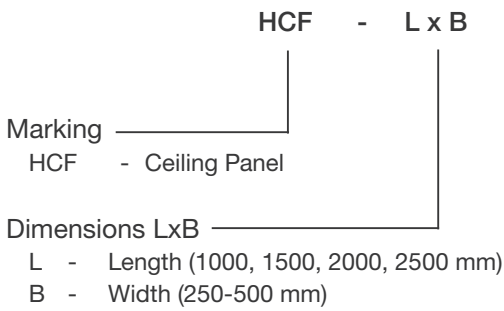

**Example: HCF 1000x500**

## HCM Noise Absorbing Ceiling Panel

HCM is a noise absorbing ceiling panel that can be used instead of regular ceiling panel.

In standard tests measuring the absorption level, this solution has reached the highest level.

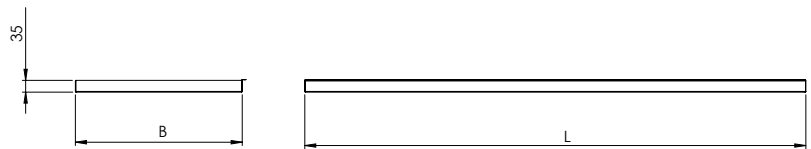

### Acoustic Performance

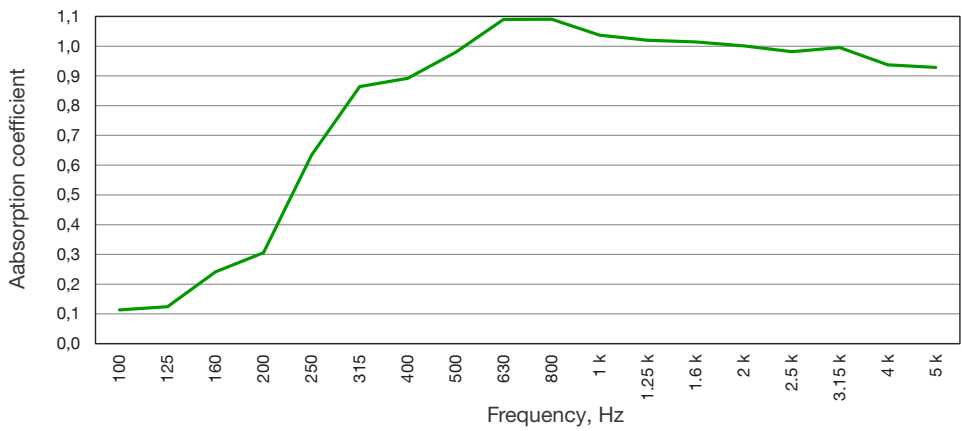

### Product marking

HCM - L x B

Marking HCM - Noise Absorbing Ceiling Panel

Dimensions LxB  
 L - Length (1000, 1500, 2000, 2500 mm)  
 B - Width (250-500 mm)

Example: HCM 1000x500

**Exhaust and Supply Corner Elements**

Corner connection elements enable to combine the chambers in a 90 degree angle for both inner and outer corner types. Solutions are compatible with HCE exhaust and HCH supply module.

**HCAE**  
Inner Corner Exhaust

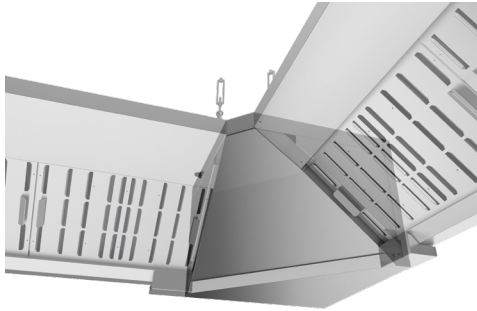

**HCAS**  
Inner Corner Supply

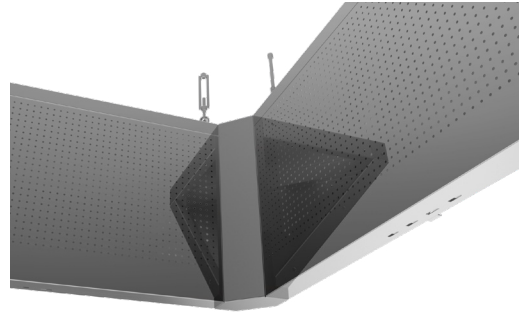

**HCAV**  
Outer Corner Supply

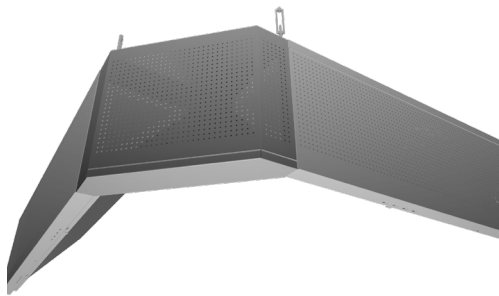

**Product marking**

HCAE - H

Marking

- HCAE - Inner Corner Exhaust
- HCAS - Inner Corner Supply
- HCAV - Outer Corner Supply

Dimension H

H - Height (400 mm)

Example: HCAE 400



**Ozone Generator**

ETS NORDs ozone cleaning technology is specifically designed for restaurants and industrial kitchens where the requirements for minimizing grease and odor within the exhaust system are high.







**Function**

Ozone (O<sub>3</sub>) is a very effective oxidant, and when mixed into a kitchen exhaust airstream it breaks down grease and odor particles to water vapor, carbon dioxide and dry minerals, all natural products of oxidation which exit the exhaust system.

Created by the process of electrical discharge, the ozone starts doing its work in the canopy exhaust chamber and thereafter throughout the greater exhaust system.

For best results with odor reduction, the reaction time for ozone within a kitchen exhaust system should be at least two seconds. However, longer exposure can further improve results. This time should be taken into account during the design phase of the kitchen exhaust system.

**Benefits obtained with ozone cleaning:**

-  Effective grease reduction
-  Significantly improved fire safety
-  Enables the use of heat recovery
-  Effectively reduces odors
-  Effective at killing bacteria
-  Low maintenance costs



Without ozone cleaning system



With ozone cleaning system

**OZ Ozone Generator Module**

Ozone Modules can be installed into supply air modules of an HC ceiling or above the Exhaust chamber.



OZ 3.x - Ozone Generator Module

**Material:** AISI 316L stainless steel  
**Working temperature:** -25 to +40°C  
**Dimensions:** 385x170x190 mm

Each Ozone Module is equipped with a pressure safety switch which only allows the unit to start when the required negative pressure is ensured. Its main switch has a 3.15 A thermal fuse.

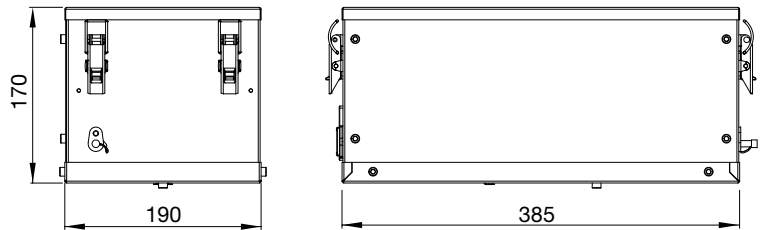

**EOZ External Ozone Generator**

The EOZ External Ozone Generator is designed for direct connection to a kitchen exhaust duct system. Its chassis contains one or more Ozone Modules and may be installed in any convenient location and orientation in your kitchen's mechanical space, as long as easy access for service is ensured.



EOZ - External Ozone Generator Module

Model	Modules quantity	b (mm)	c (mm)	Ød (mm)	Weight (kg)	Voltage (V, Hz)	Max power (W)
EOZ-1	1	250	125	125	13	230/50	300
EOZ-2	2	450	225	160	20	230/50	600

**Material:** AISI 316L stainless steel  
**Working temperature:** -25 to +40°C  
**Dimensions:**  
 See diagram and table above

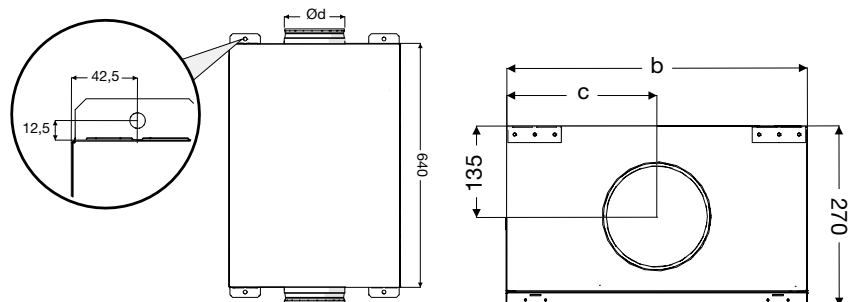

## Control Panel

All Ozone Modules, whether they are installed within kitchen canopies or EOZ External Ozone Generators, are managed by an intelligent central Control Panel. The Control Panel monitors the operation of each Ozone Module and will trigger an alarm in case of any failure or the need for maintenance. Compared with ozone and UV solutions from other manufacturers, only one Control Panel is needed per kitchen, regardless of the number of ozone generators installed.

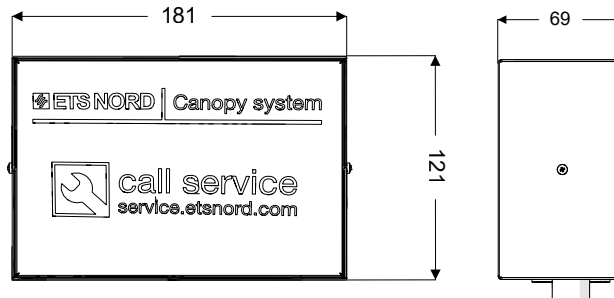

The Control Panel monitors all ozone generators on the premises with an advanced control and reporting technology and can be connected to either BACnet or Modbus-driven systems, enabling remote management via either the local network or Internet.

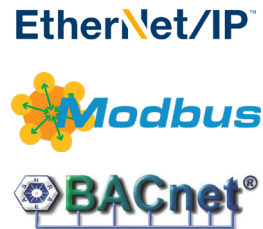

### Advantages:

- Compatibility with building automation
- Remote monitoring (IoT - Internet of Things)
- Data visualization and history
- Easy and safe to use



This symbol indicates that when the end-user wishes to discard the device, it must be taken to a proper waste station for recycling.

**For further installation and technical information, please consult the product manuals provided with your shipment, or contact your ETS NORD representative to obtain all available documentation.**

## HFK Grease Filter

HFK is a high efficiency grease filter designed for use in ventilation hoods of commercial kitchens or other food production facilities. They are positioned in the hood exhaust plenum above cooking appliances (stoves, grills, etc.) and separate grease and other particles out from the exhaust air stream.

The ETS NORD HFK grease filter is protected by utility patent no. 01310.

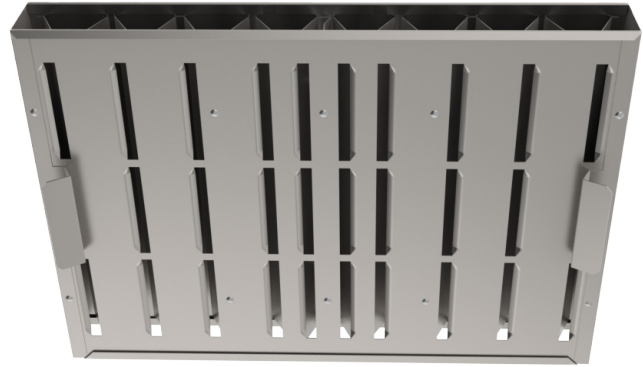

- High efficiency captures 97% of 10 micron particles
- Functions well even with variable air volume systems
- Low pressure drop provides energy-efficient operation
- Flame resistance class A according to DIN 18869-5
- Easy to maintain

### Material and Design

HFK filters are manufactured from AISI 304 stainless steel. They are assembled with rivets to ensure their durability through many years of use in challenging kitchen environments.

### Operation

The greasy effluent from cooking appliances is pulled through the openings in the front panel of the filter. Our patented double-triangular cross-section within the chamber causes a high speed centrifugal swirling of the air. The rapid change of trajectory of the grease particles causes them to collide with the filter surfaces, resulting in their effective separation from the air stream. The grease then drains from the filter down and into the grease collection channel of the hood. The filtered air continues on into the kitchen exhaust system through the top and bottom orifices of the filter.

The optimal operating conditions of the HFK Grease Filter are under a pressure drop from 12-48 Pa with an airflow through each filter from 70-130 l/s, ensuring an energy efficient operation.

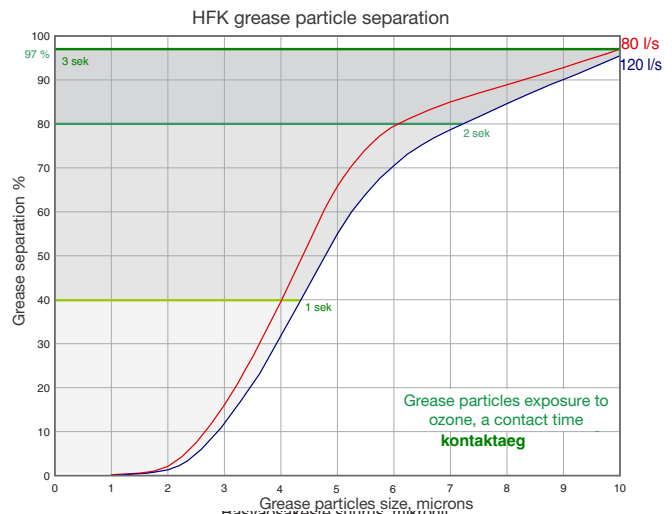
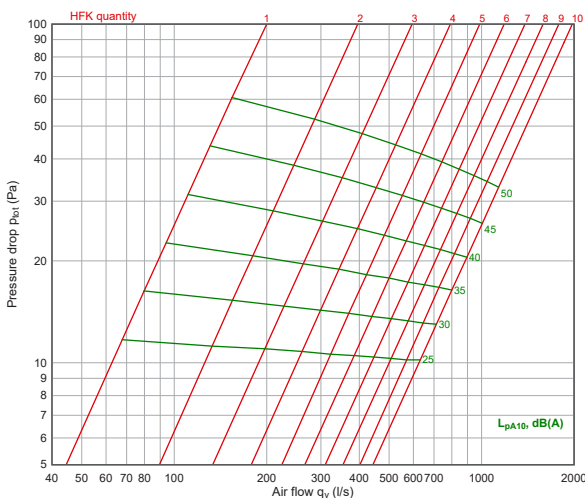

## FET "Helping Hand" filter removal tool

- With the ETS NORD "Helping Hand" filter tool, professional kitchen operators can safely and easily service their grease filters.
- Helping Hand allows grease filters to be removed and replaced without the cumbersome need to climb on or reach over kitchen equipment.
- The daily filter washing process is significantly simplified, thus ensuring its completion by the responsible staff.
- The tool's length is fully adjustable, thereby enhancing ergonomic comfort.





### ETS NORD AS

Address: Peterburi tee 53  
11415 Tallinn  
Estonia

Phone: +372 680 7360  
sales@etsnord.ee  
www.etsnord.ee

### ETS NORD Finland

Address: Pakkasraitti 4  
04360 Tuusula  
Finland

Phone: +358 401 842 842  
info@etsnord.fi  
www.etsnord.fi

### ETS NORD Sweden

Address: Järsjögatan 7  
69235 Kumla  
Sweden

Phone: +46 19 554 20 50

---

Address: Pinjegatan 5  
21363 Malmö  
Sweden

Phone: +46 40-94 68 70  
info@etsnord.se  
www.etsnord.se



*Let's move the air together!*