

DVS Exhaust valve

DVS exhaust valve is suitable for ventilation systems with small air volumes.



Structure and dimensions

Manufactured of galvanized steel and coated white (RAL 9003).

The valve body includes an elastic foam seal.

Size	ØA	ØB	ØC	ØE	L	L1	Weight, kg
100	98	125	92	137	40	45	0,12
125	123	150	115	164	45	45	0,3
160	159	185	148	212	55	45	0,4
200	198	225	188	248	60	45	0,5
250	248	290	240	300	70	45	1,2

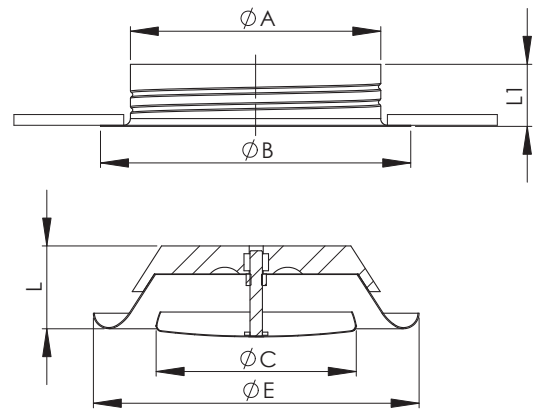

Technical data

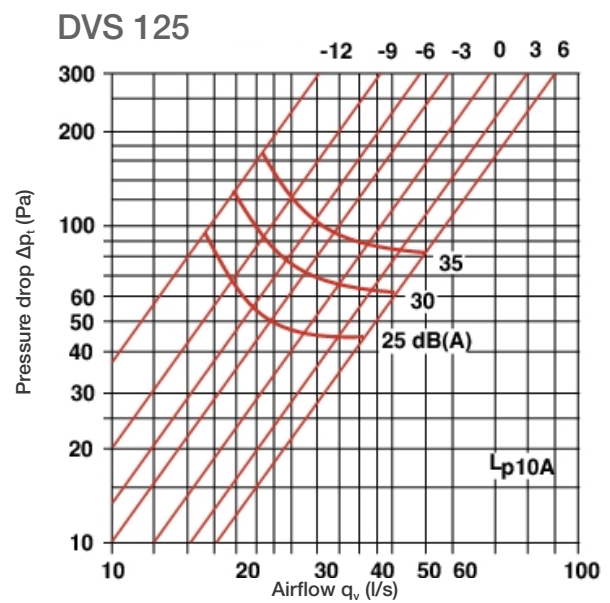
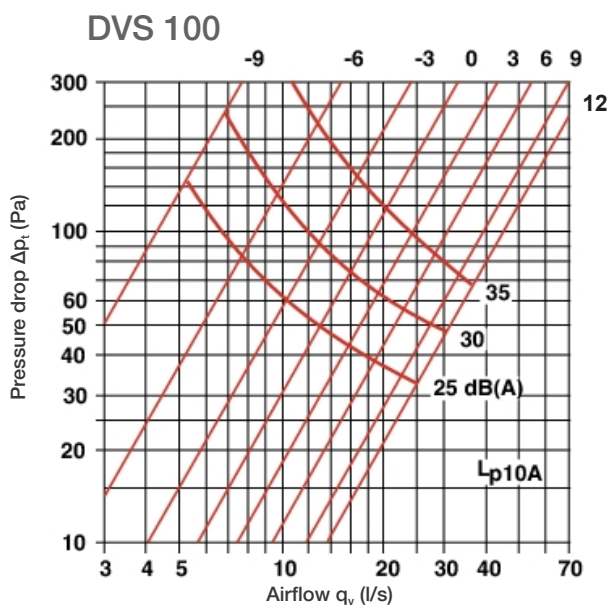

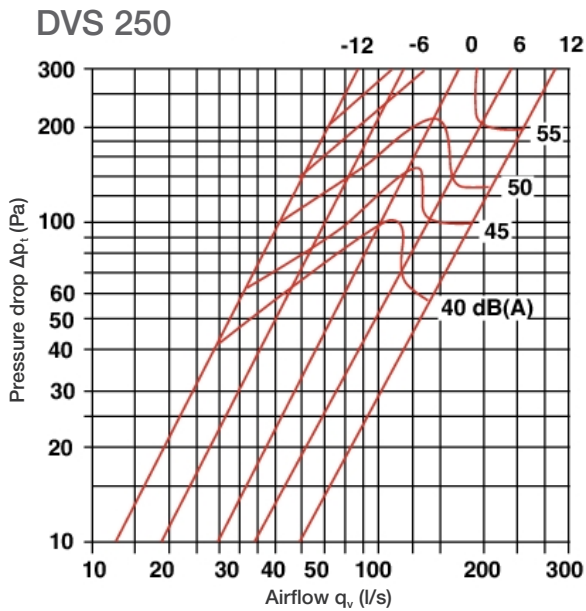
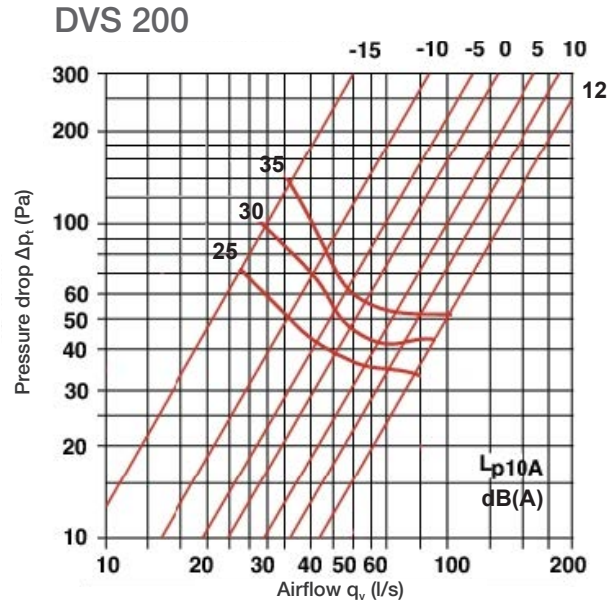
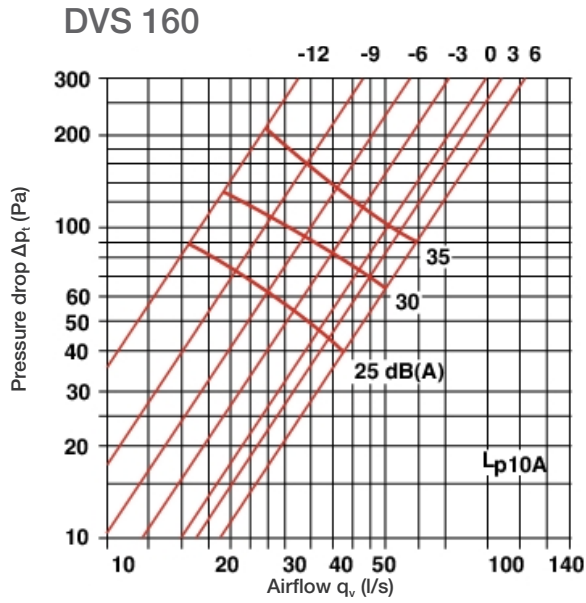

Product codes

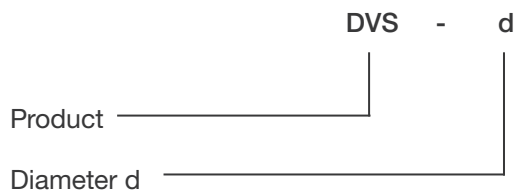

Example: DVS 200

Installation

Installation to duct using a mounting frame (included).

Measurement and regulation of air flow

Measurement of air flow through pressure differential measured with a separate measuring device.

Regulation by opening or closing by turning the plate.

K-value a, mm	-12	-9	-6	-3	0	3	6	9	12
DVS 100		0,45	0,80	1,20	1,50	1,80	2,25	2,65	2,95
DVS 125	0,80	1,25	1,65	2,10	2,60	3,00	3,45	4,00	4,50
DVS 160	2,10	2,35	3,00	3,70	4,20	4,95	5,45	6,25	6,90
DVS 200	3,15	3,90	4,75	5,15	6,25	7,40	8,25	8,95	10,00
DVS 250	5,85	6,95	8,05	9,45	10,30	10,85	12,35	13,75	15,50

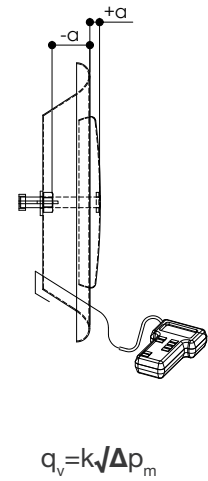

Maintenance

Remove the inner cone by turning counter-clockwise. Clean surfaces with damp cloth. Replace inner cone in its original position.