

DPL Adjustable swirl diffuser

DPL/DPLS is a adjustable swirl diffuser for high-ceilinged rooms. Thanks to its adjustable blades the airflow can be either horizontal or vertical and is thus suitable for both cooling and heating.

Positioning the blades at angles between 45° to 90° is suitable for cooling, and angles below 45° are suitable for heating. Adjusting can either be done manually or with the help of an actuator.

Suitable usage locations are hospitals, office rooms, restaurants and other public premises.

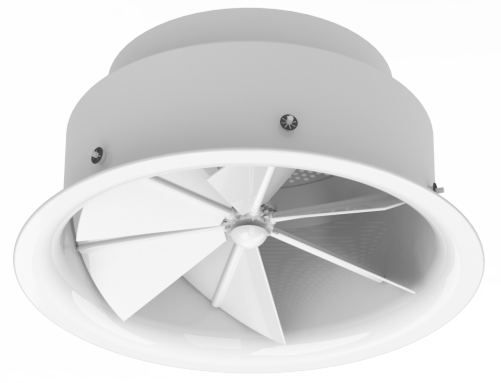

- Suitable for both cooling and heating
- Horizontal and vertical airflow
- High inductance
- Suitable for connecting to an actuator

Quick selection

Nominal size Ød	Air volume (l/s) (blades positioned at 45°)			Recommended installation height, m
	L _w 20 dB(A)	L _w 35 dB(A)	L _w 50 dB(A)	
250	50	146	251	3-5,3
315	76	238	407	3,3-6
400	125	385	516	4,3-7,5
500	208	526	889	5,5-16
630	318	935	1617	7,5-26

Models

DPL - manually adjustable rotary diffuser (the blades can be adjusted individually)

DPLS - rotary diffuser with simultaneously adjustable blades. When using an actuator to adjust, Belimo LM24A-SR, NM24A-SR or SM24A-SR actuators are recommended.

DPLT - rotary diffuser equipped with a thermostat. The blades of the air diffuser are adjusted automatically without using electrical control. When using an actuator equipped with a thermostat, blade adjustment is based on the supply air temperature. The operating temperature of the air diffuser is -15 °C to 40 °C.

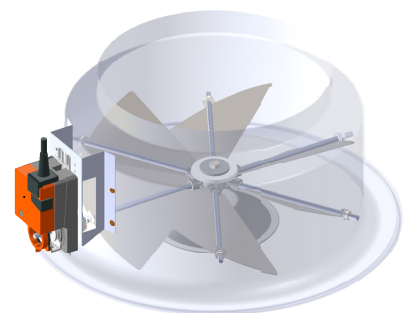

Design and dimensions

The casing of the DPL rotary diffuser is made of an aluminium sheet and blades of steel sheet. The diffuser is powder coated white (RAL 9010). The diffuser is equipped with a leveller plate.

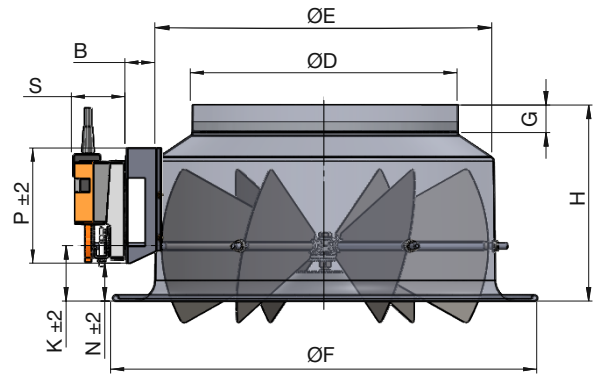

Nominal size Ød	D	E	G	H	F	K	B	P	S	N	Belimo actuator
200	198	248	40	180	350	47	30	135	61	28	LM24A-SR 5 Nm
250	248	298	40	205	400	55	30	135	61	36	LM24A-SR 5 Nm
315	313	398	40	230	500	64	30	135	61	45	LM24A-SR 5 Nm
400	398	465	60	270	615	64	60	160	62	45	NM24A-SR 10 Nm
500	498	565	60	320	780	90	80	160	62	71	NM24A-SR 10 Nm
630	628	665	80	390	935	120	100	196	64	84	SM24A-SR 20 Nm

Technical data

Terms used:

V_o [m/s] – airflow rate in the channel

V_f [m/s] – airflow rate within the occupancy area

$l_{0,2}$ [m] – airflow range

DPL 250 +5K

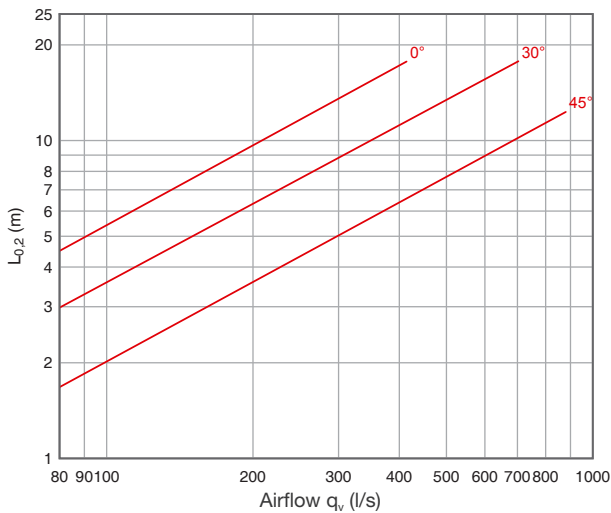

DPL 250 -5K

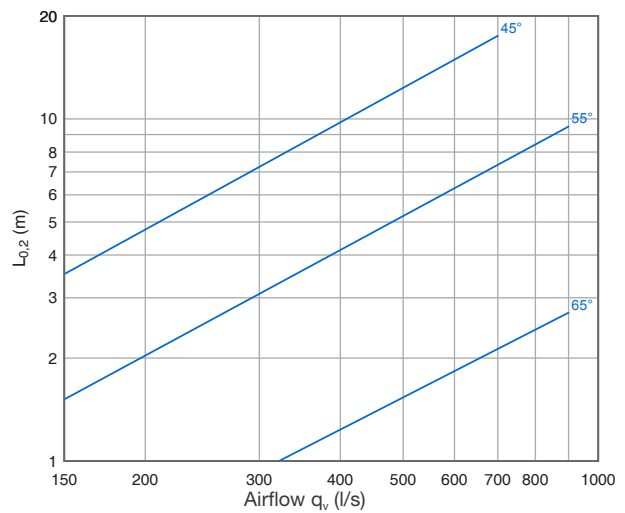

DPL 250 +10

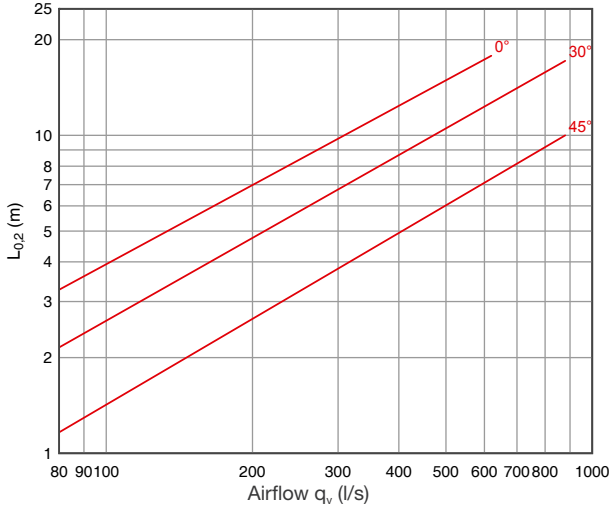

DPL 250 -10K

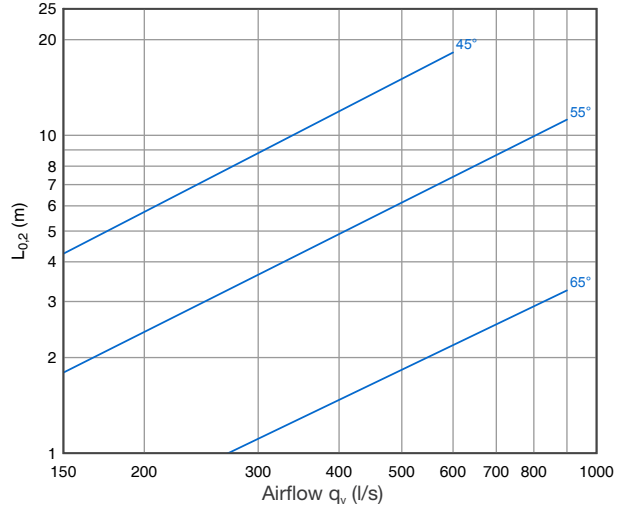

DPL 250 +15K

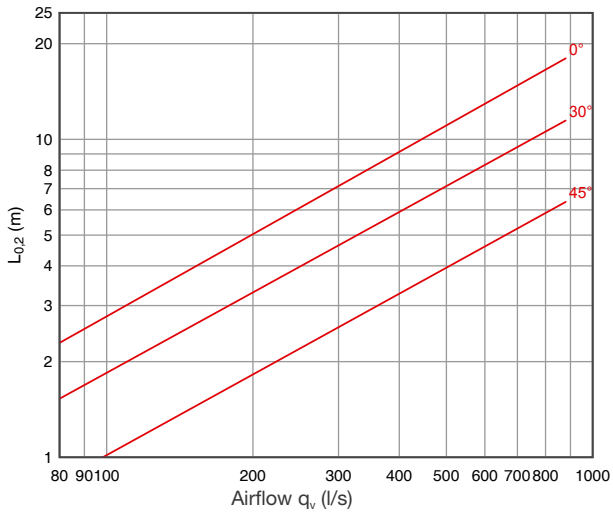

DPL 250 -15K

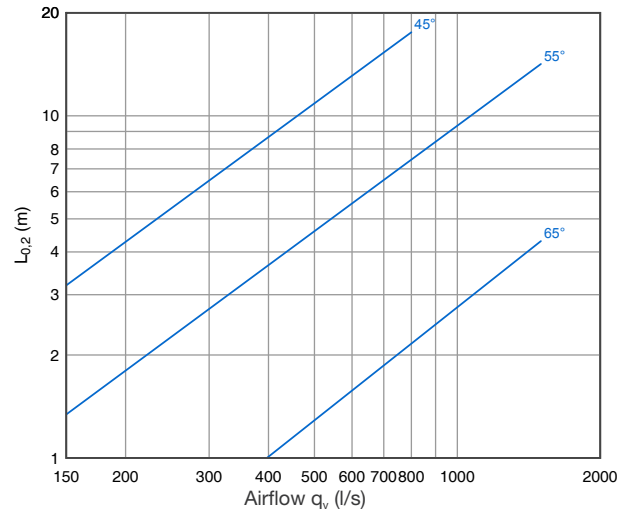

DPL 315 +5K

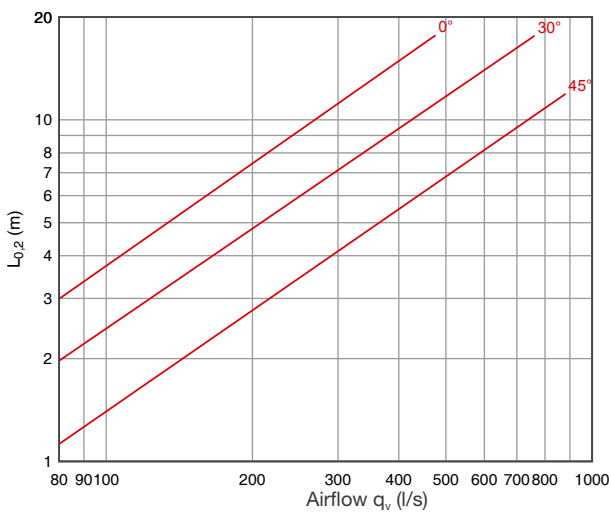

DPL 315 -5K

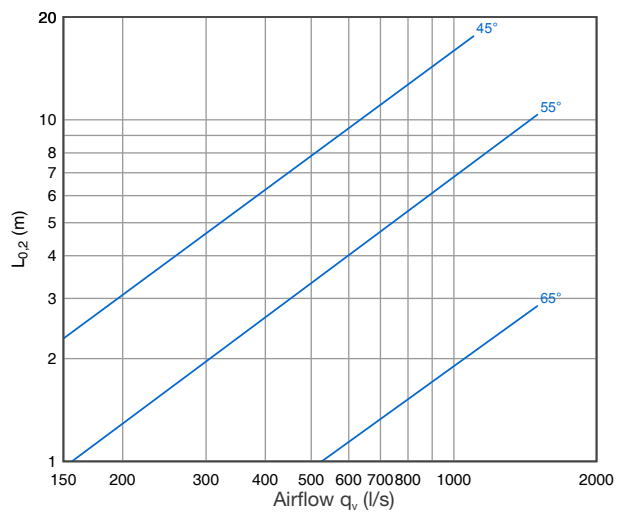

DPL 315 +10K

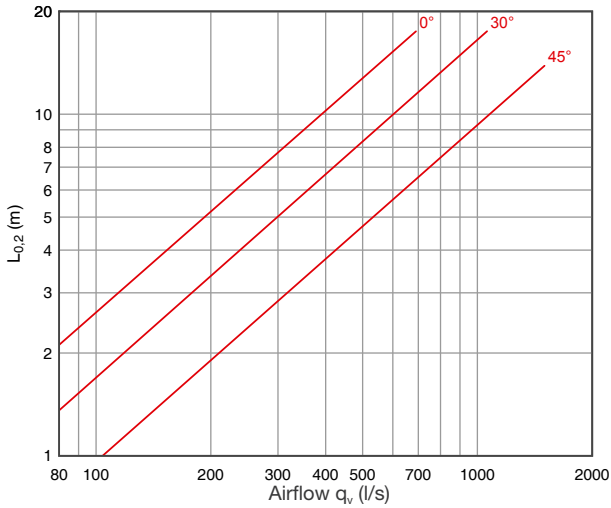

DPL 315 -10K

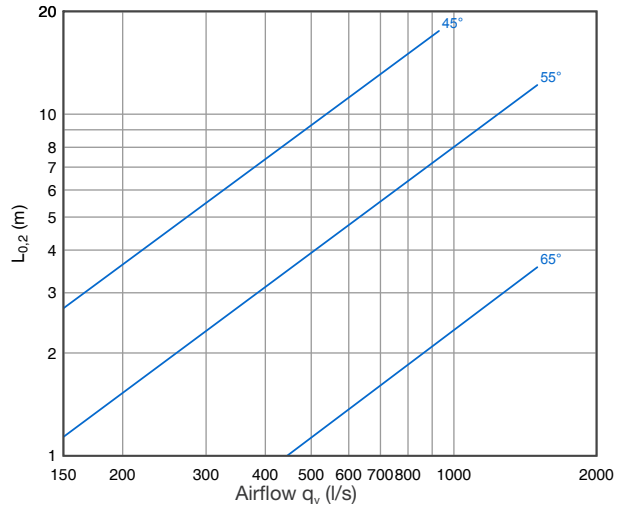

DPL 315 +15K

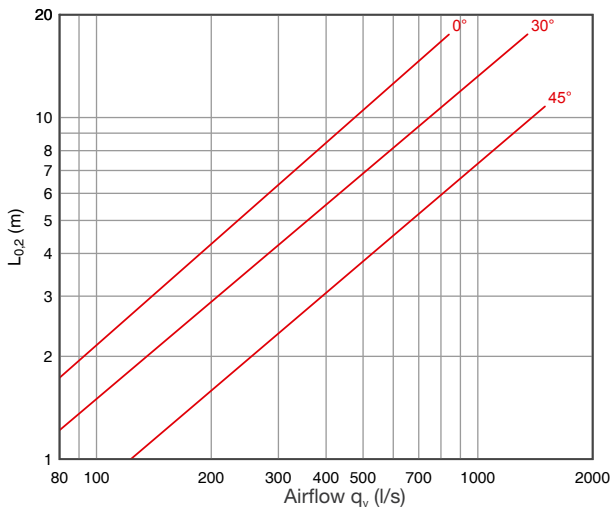

DPL 315 -15K

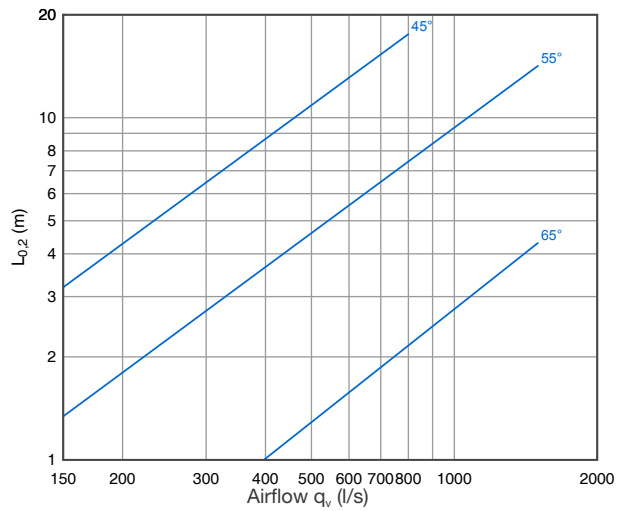

DPL 400 +5K

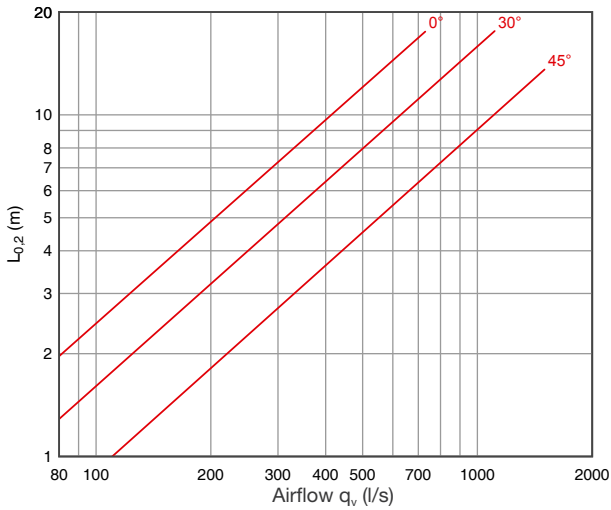

DPL 400 -5K

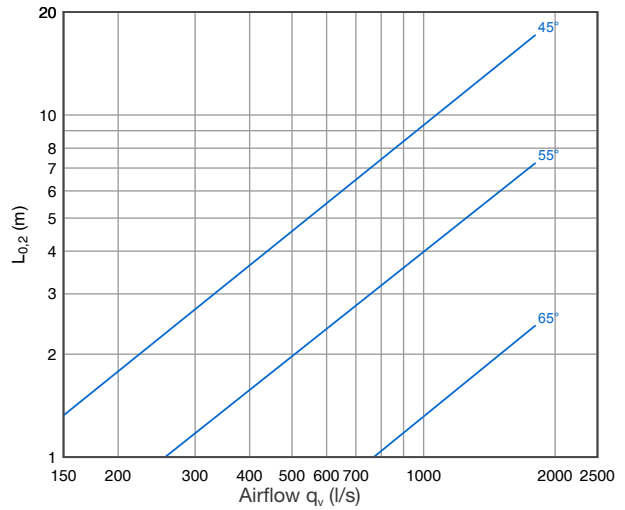

DPL 400 +10K

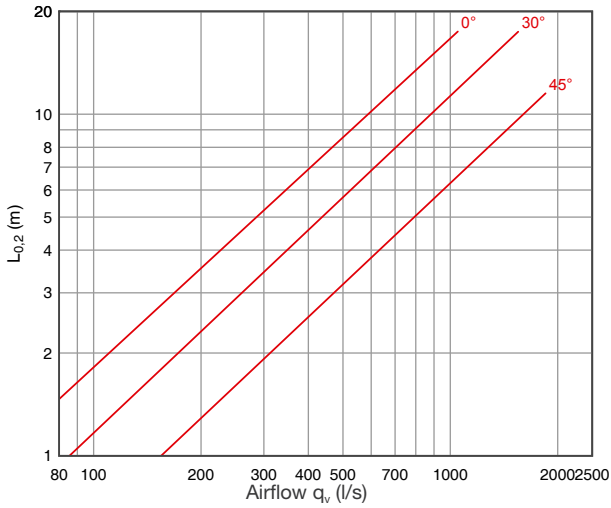

DPL 400 -10K

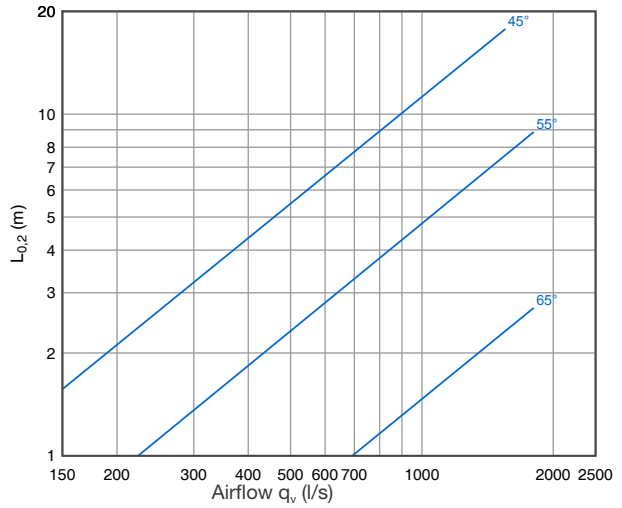

DPL 400 +15K

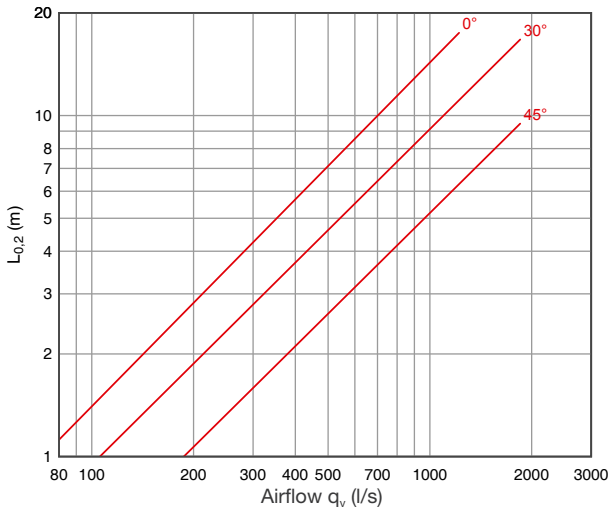

DPL 400 -15K

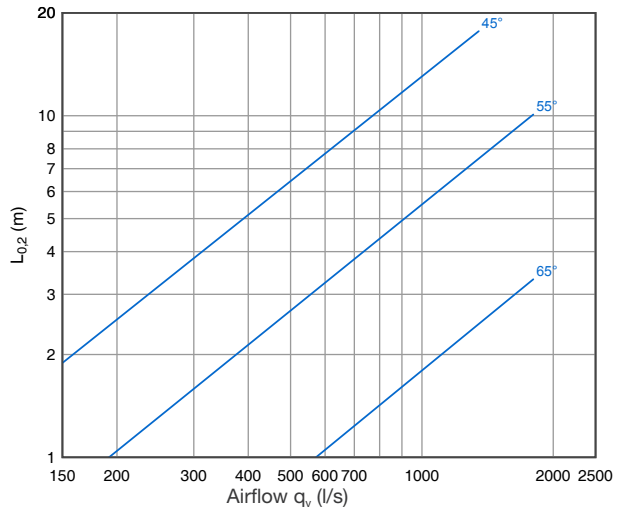

DPL 500 +5K

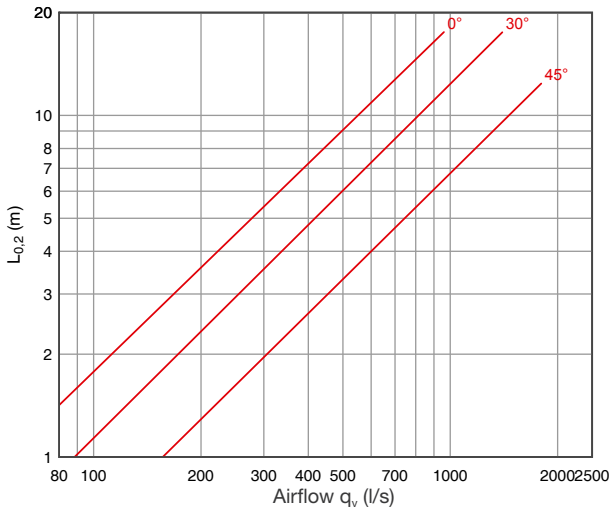

DPL 500 -5K

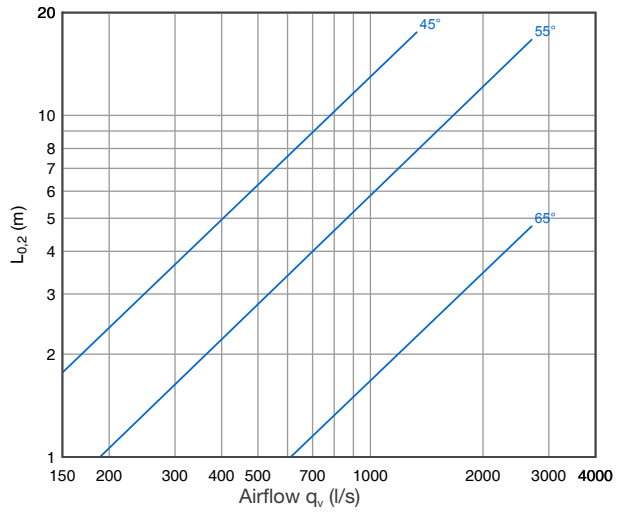

DPL 500 +10K

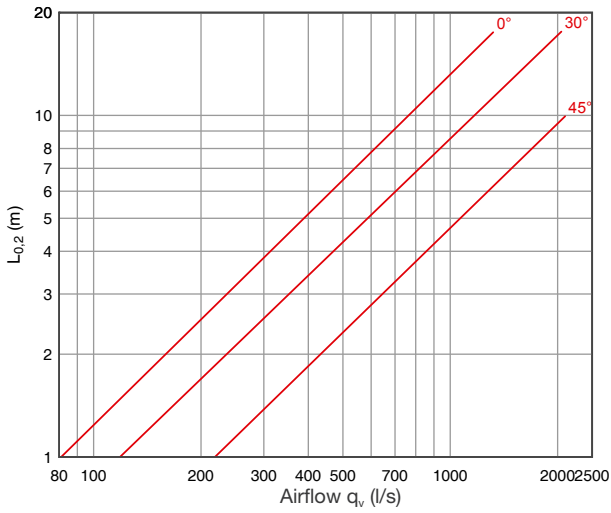

DPL 500 -10K

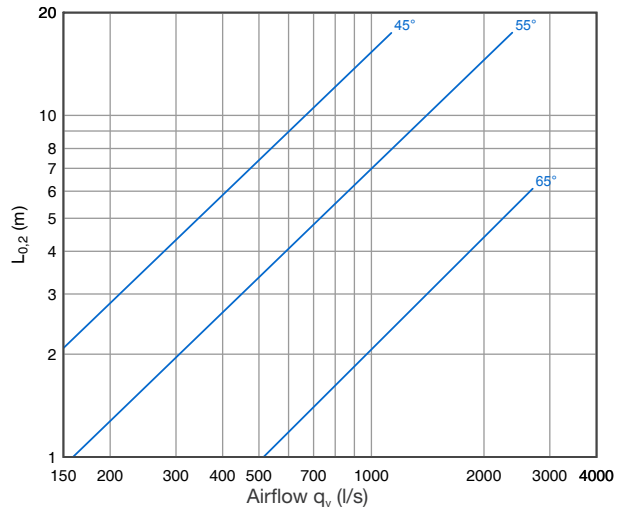

DPL 500 +15K

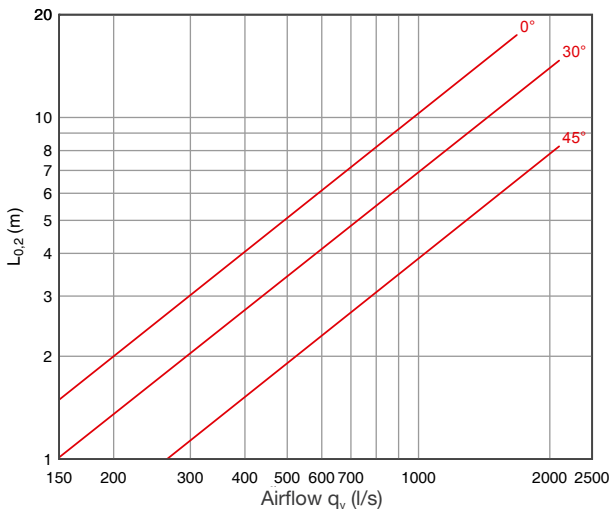

DPL 500 -15K

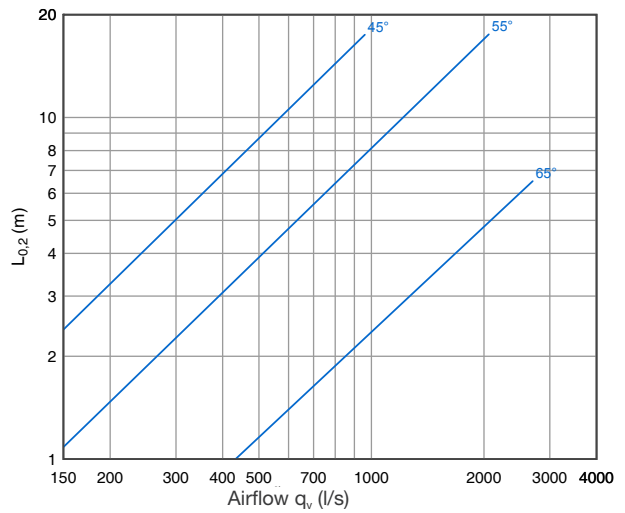

DPL 630 +5K

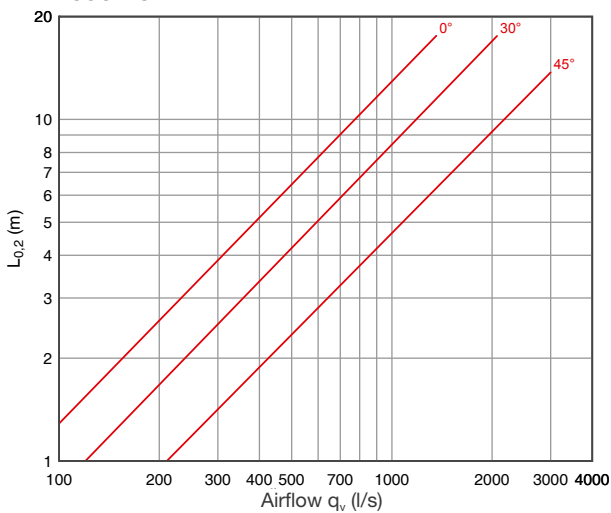

DPL 630 -5K

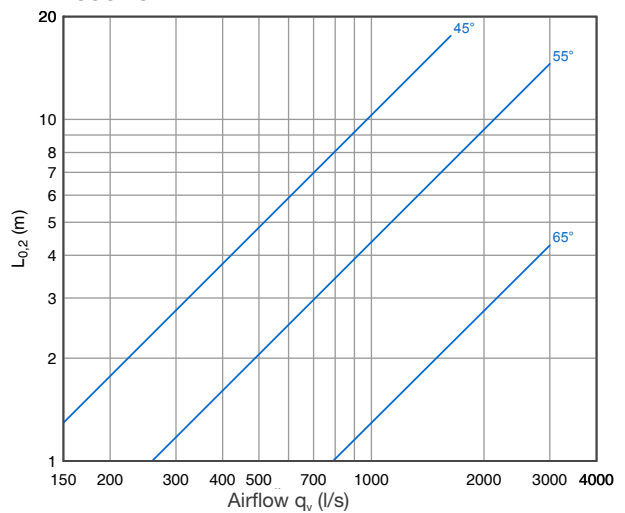

DPL 630 +10K

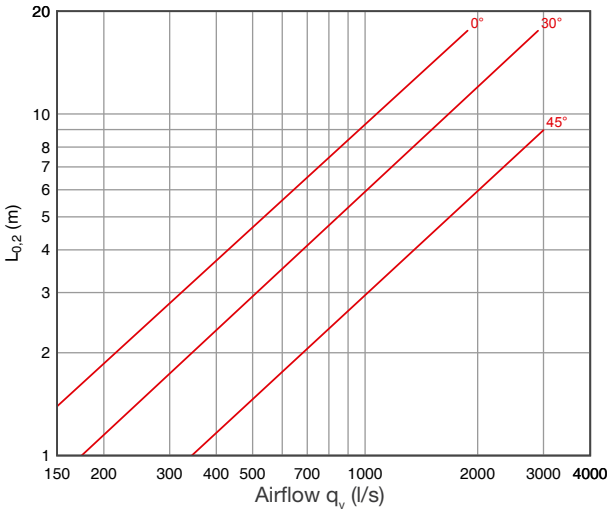

DPL 630 -10K

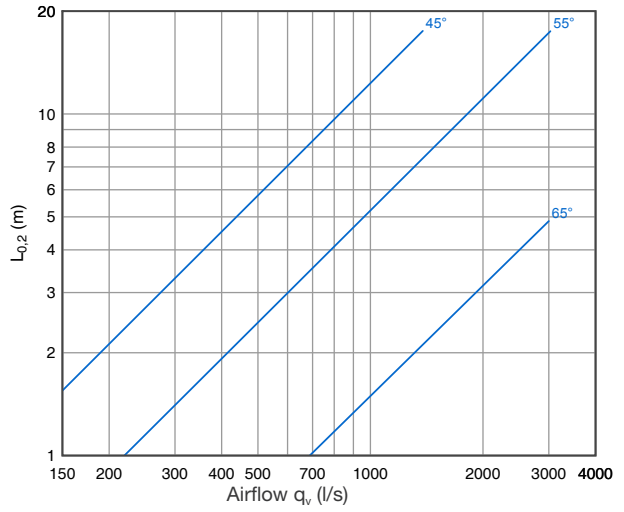

DPL 630 +15K

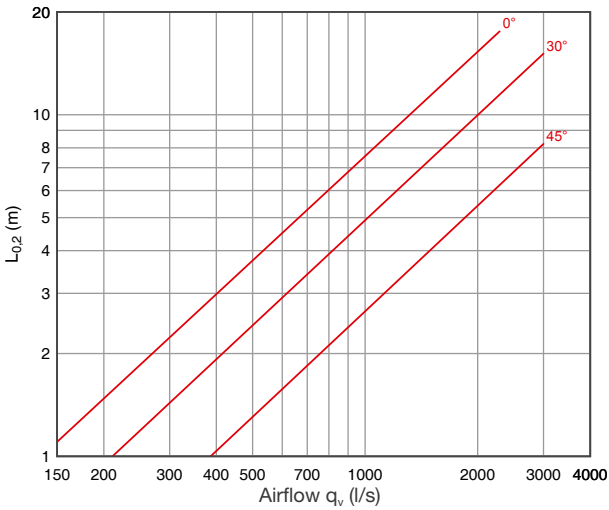

DPL 630 -15K

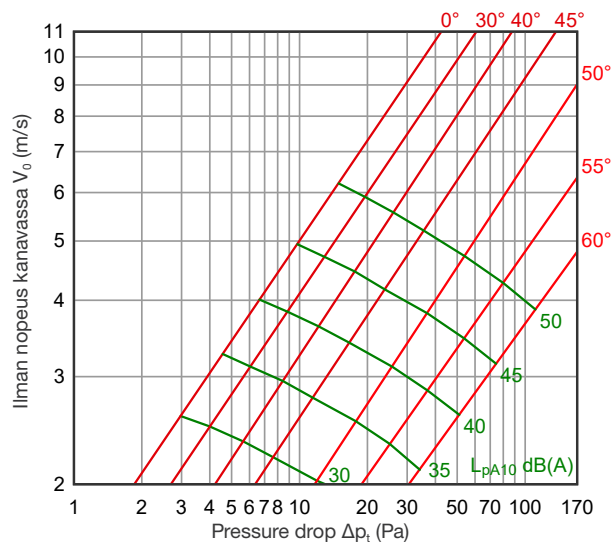
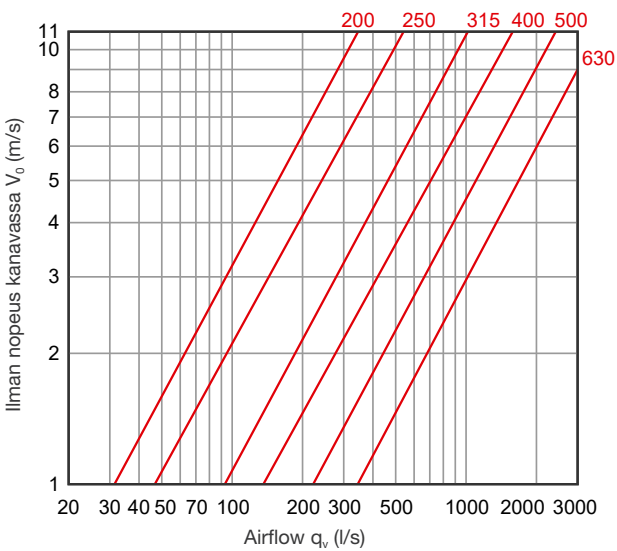
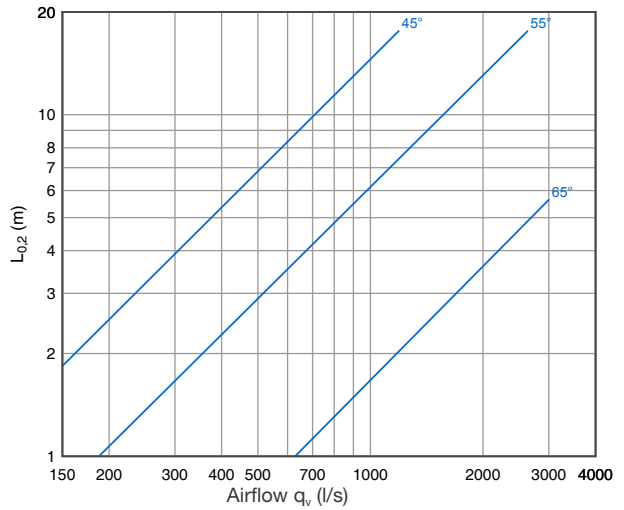

Markeerimine



Näidis: DPL 200

Installation

The DPL air distributors are suitable for connecting either directly to the duct or to a blenum box.

Blade positioning

Air distributors are supplied from the factory with their blades preset at a 50° angle. If another position is desired, adjustment must be performed on the site.

The DPLT air distributor does not require factory presetting.