



NORDcanopy

EOZ 2.1 Ozone Generator

Keeps kitchen exhaust ducts clean

Ensures better fire safety

Significantly reduces kitchen exhaust duct maintenance costs

Compatible with building automation

EOZ 2.1 Ozone Generator

EOZ 2.1 Ozone Generator is designed for direct connection to a kitchen exhaust duct system and is appropriate for use in either new or existing kitchen ventilation. EOZ 2.1 contains either one or two OZ 4.0 Ozone units.

EOZ 2.1 can be installed in any convenient location and desired position as long as easy access for service and maintenance is ensured. This device is controlled and monitored through a LCD control panel located in the kitchen.



Benefits obtained with ozone cleaning:

-  Effective grease reduction
-  Significantly improved fire safety
-  Enables the use of heat recovery
-  Effectively reduces odors
-  Effective at killing bacteria
-  Low maintenance costs
-  Can be installed in any orientation

Function

Ozone (O₃) is a very effective oxidant, and when mixed into a kitchen exhaust airstream it breaks down grease and odor particles to water vapor, carbon dioxide and dry minerals.

Created by the process of electrical discharge, the ozone starts doing its work in the canopy’s exhaust chamber and thereafter throughout the whole exhaust system.

Note! For results with exhaust air odor reduction, the reaction time for ozone within a kitchen exhaust system should be at least two seconds. However, longer exposure can further improve results. Time should be taken into account during the design phase of the kitchen exhaust system.



Exhaust duct without ozone cleaning system



Exhaust duct with ozone cleaning system

EOZ 2.1 Ozone Generator features

The system is monitored and controlled through a LCD control panel and if there is an internet connection, through the web interface. The control panel displays system malfunctions and informs the kitchen staff about them. ETS NORD EOZ 2.1 Ozone generators can be connected to building management system through Modbus RTU or TCP/IP (only through IoT device). EOZ 2.1 ozone generator can be operated via work permission from the building management system.

In order to save energy with the ozone cleaning system, it is possible to use an automated solution Smart Mode, which sets specific time periods for the ozone units when the devices work at full power and when at minimum power. Using the Smart Mode gives the ozone unit a longer life and makes it more energy efficient. Consult with an ETS NORD technician before using the Smart Mode to determine if necessary requirements are met to clean the system.

EOZ 1 - 2.1 consists of one OZ 4.0 Ozone unit and EOZ 2 - 2.1 consists of two OZ 4.0 Ozone units. EOZ 2.1 can be used together in one system with OZ 4.0 Ozone units which are located inside the canopies.

A maximum of 9 OZ 4.0 Ozone units can be in one system, behind one LCD control panel.

For example: four OZ 4.0 Ozone units inside the canopies, two EOZ 2 - 2.1 Ozone generators (total of four OZ 4.0-s) and one EOZ 1 - 2.1 (total of one OZ 4.0) Ozone generator.

Safety:

- Ozone unit will shut down if the pressure in the exhaust duct drops below 20 Pa;
- Electronic parts are protected by thermal protection;
- Meets kitchen ozone safety requirements;
- HACCP International certificate;
- CE certified.



Compatibility with building automation:

- Modbus RTU and I/O status signals are included as standard;
- Modbus TCP/IP and LAN connectivity is included with additional remote access device;
- Data flow with building automation – alarm and maintenance notifications, working status, etc.
- Gives work permission to ozone units either locally (through potential free contact) or remotely (Modbus);
- Remote monitoring (IoT - Internet of Things) from the local area network or internet provided by additional remote access device;
- Automated time schedule option.



Construction

EOZ 1 - 2.1

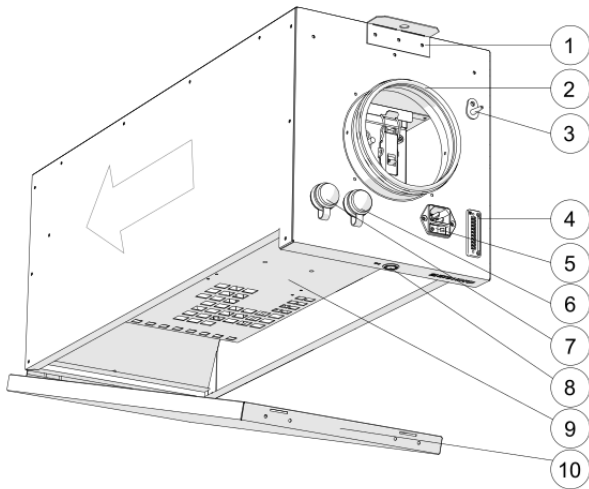

- 1 – Suspension brackets
- 2 – Supply air connection
- 3 – Ambient air pressure nozzle (+)
- 4 – EOZ 1 - 2.1 unit input connector X1
- 5 – Power supply socket
- 6 – M-Link socket
- 7 – LCD control panel socket

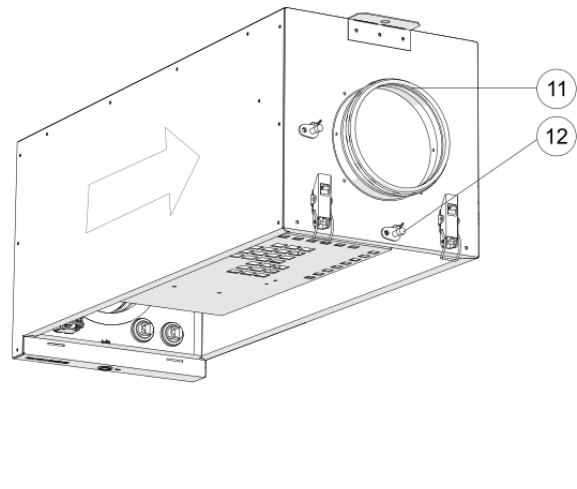

- 8 – Status LED
- 9 – OZ 4.0 Ozone unit
- 10 – Service hatch
- 11 – Exhaust air connection
- 12 – Exhaust air pressure nozzle (-)

EOZ 2 - 2.1

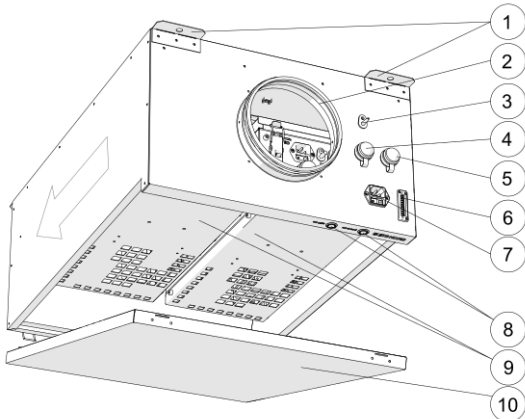

- 1 – Suspension brackets
- 2 – Supply air connection
- 3 – Ambient air pressure nozzle (+)
- 4 – M-Link socket
- 5 – LCD control panel socket
- 6 – EOZ 2 - 2.1 unit input connector X1
- 7 – Power supply socket

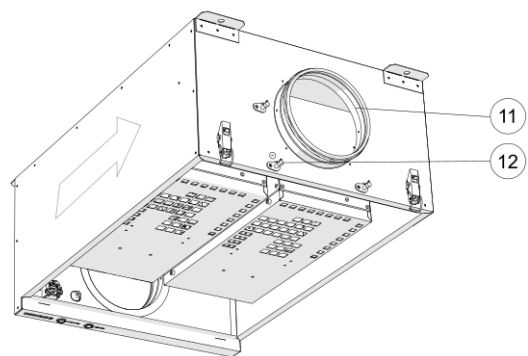

- 8 – Status LEDs
- 9 – OZ 4.0 Ozone units
- 10 – Service hatch
- 11 – Exhaust air connection
- 12 – Exhaust air pressure nozzle (-)

EOZ 2.1 Dimensions and Technical Data

Technical data:	EOZ 1 - 2.1	EOZ 2 - 2.1
Number of ozone units inside	1	2
Max ozone capacity*	5000 mg/h	10 000 mg/h
Treated exhaust airflow	max 700 l/s	max 1400 l/s
Recommended airflow through EOZ 2.1	30 l/s	60 l/s
k-value	4,93	9,34
Nominal voltage	230 V, AC	
Power consumption	max. 330 W	max. 660 W
Nominal frequency	50 Hz	
Max input current of the unit	max. 1,8 A	max. 3,6 A
Short-circuit current withstand capability (I _{cc} ; C16 circuit breaker on the supply side)	2 kA	
Overvoltage category	II	
Protection against electric shock	Basic insulation + switch-off of the automatic power supply	
IP rating of the housing	IP2X	
Pollution degree	I	
Ambient temperature range during operation	0 ... +50 °C	
Ambient temperature range during storage	-20 ... +70 °C	
Ambient relative humidity during operation	max. 90 %RH/+20 °C (50 %RH/+40 °C)	
Operating altitude above sea level	max. 1000 m	
Internet connection	Via remote access device	
Building management system	Modbus RTU or TCP/IP	
Fire alarm connection	1 discrete input (requires a potential-free output)	
Max amount of ozone units in one system	9	
Dimensions (height x width x depth)	250x640x270 mm	450x715x270 mm
Unit material	Stainless steel AISI 316L, thickness 0,8 mm	
Weight	13,2 kg	20,4 kg
Basic standard	EVS-EN 60335-1:2012+A11+A13+A14+A2+A15:2021	
EEC standard	EVS-EN IEC 61000-6-2:2019, EVS-EN IEC 61000-6-3:2020	
LCD control panel IP rating	IP20	
LCD control panel ambient temperature range during operation	0 ... +50 °C	

* Maximum ozone output capacity is obtained under the following conditions: measured at 10 meters in the duct from the ozone unit, supply air temperature 20°C and relative humidity 20%.

EOZ 1 - 2.1 Ozone generator dimensions

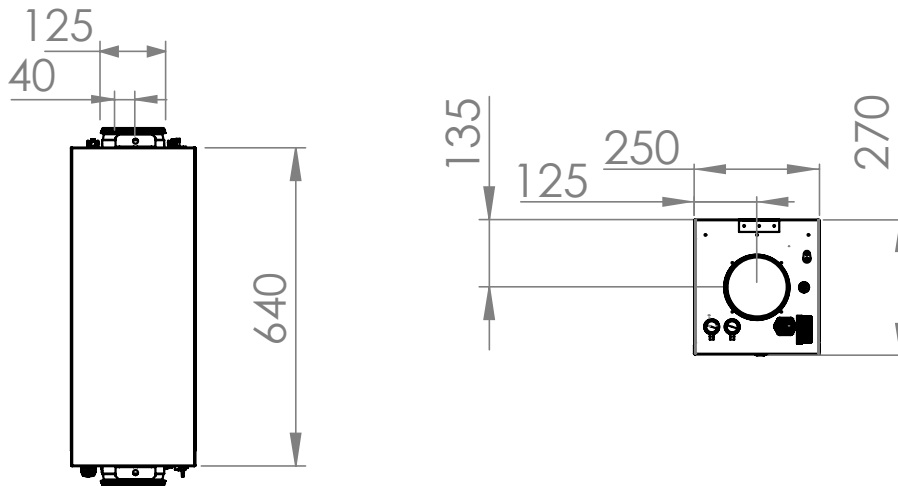

EOZ 2 - 2.1 Ozone generator dimensions

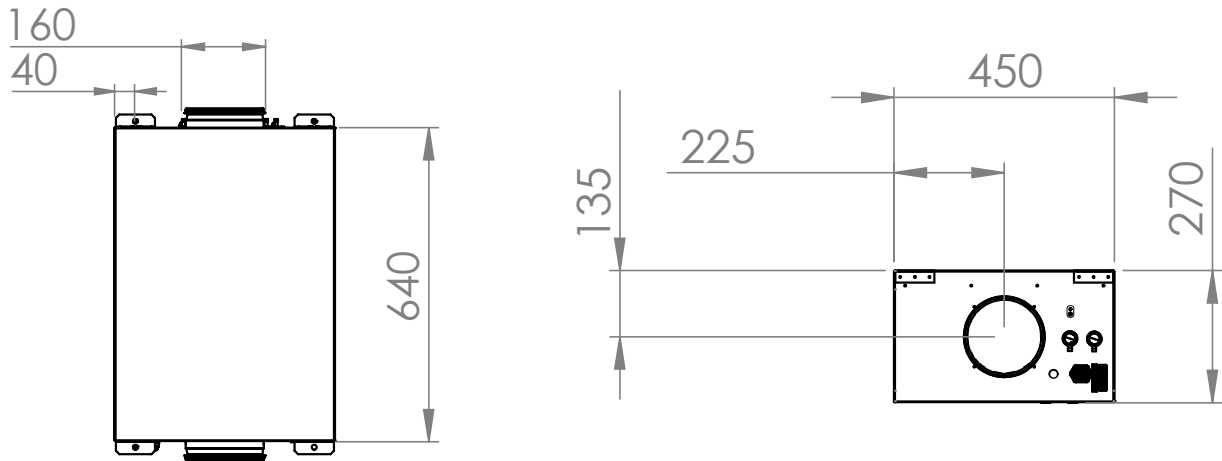

LCD control panel dimensions

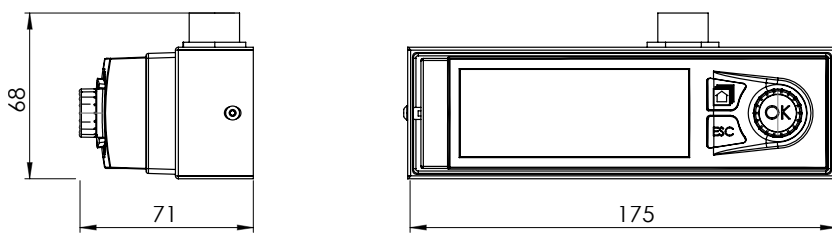

Necessary connections of the ozone unit:

- LAN cable from the LCD control panel to the Master ozone unit (Cat 6 cable);
- Power supply.

Optional connections:

- Modbus data cable between master and slave units (twisted pair cable min 2x2x0,25). Is needed when there is more than one ozone unit in the ozone cleaning system;
- Building management system cables (Modbus RTU, working permission, I/O status signals);
- Ethernet connection to the remote access device.

For more information, check OZ 4.0 Ozone unit installation manual.

Maintenance

Ozone generators from inside the ozone unit must be changed after 10 000 operating hours. When the service interval of 10 000 hours is full then the system notifies the user with an alarm through the LCD control panel or LED notification panel and the BMS if it is connected.

Maintenance of the ozone units is carried out only by the authorized personnel of ETS NORD or our service partners.

LED notification panel

The LED notification panel is designed to visually convey to the user in a simplified manner the status (operational/requires maintenance/errors) of the ozone unit(s) inside the EOZ 2.1 Ozone Generator. Meant as a stand-alone visual notification helper to the user.



The notification panel displays to the user whether the ozonator:

- is working;
- has critical errors and maintenance is necessary;
- service interval is full, and the system must be serviced.

In case of critical errors and maintenance, contact ETS NORD service: <https://www.etsnord.com/contact-info/service/>

LED notification panel dimensions

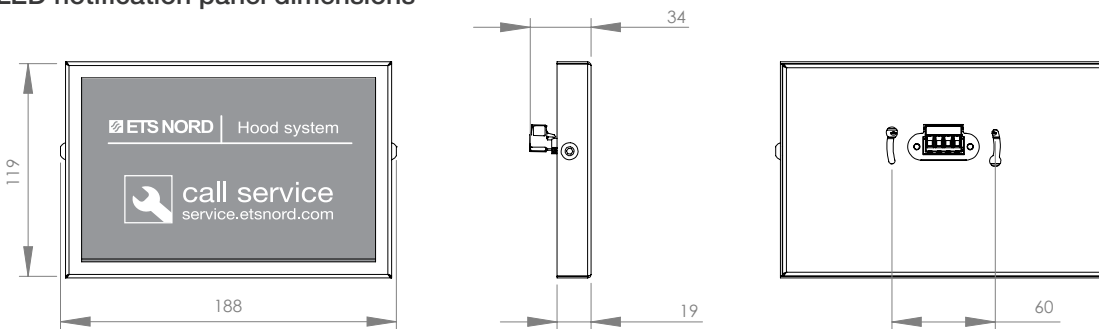

Installation location

The EOZ 2.1 Ozone Generator should be connected directly after the canopy grease chamber, so that the cleaning process is as efficient as possible. When installing, you must observe the direction of the air flow and that nothing is blocking the necessary access for device servicing.

NB! EOZ 2.1 must be installed in a way it has easy access for service and maintenance, preferably right above the ceiling. Removal of the ozone units inside must be enabled.

Note: All ducts, fittings, screws, or rivets from the exhaust connection of the generator to the exhaust duct must be manufactured from at least AISI 316 stainless steel.

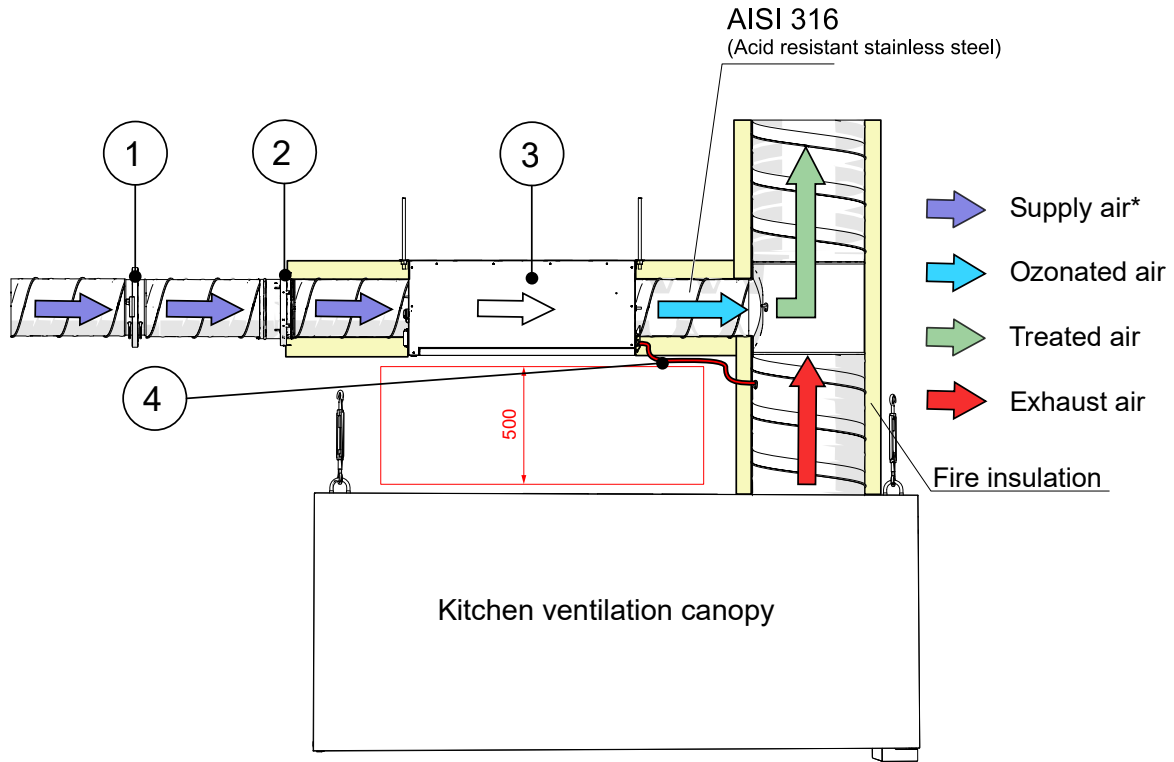

*Supply air must be clean air coming from the air handling unit.

- | | |
|---------------------------|-----------------------------|
| 1 - KRI Regulating damper | 3 - EOZ 2.1 Ozone Generator |
| 2 - Fire damper* | 4 - Pressure tube |

ATTENTION! Fire dampers are used in accordance with local and country codes.

Facts about ozone

- Ozone is a colourless gas, the sharp smell of which can be detected by a person at a concentration of 0.02 ppm (0,4 mg/m³).
- The smell of ozone is similar to the smell of chlorine used in swimming pools.
 - The use of ozone is subject to the applicable protection legislation. For example, in Sweden, the Swedish Work Environment Authority provides the following hygienic limits for ozone:
 - HTP value: 0.1 ppm (during working time, 8 hours)
 - HTP value: 0.3 ppm (15 minutes)
- Acute exposure to ozone may result in the following damage:
 - skin irritation and burning sensation
 - severe irritation and burns in eyes and vision loss
 - pulmonary irritation in the respiratory tract and respiratory problems
- If the presence of ozone is detected indoors, the ozone generator must be switched off immediately and the area must be ventilated.

For further installation and technical information, please check our website or contact your ETS NORD representative.



ETS NORD AS

Address: Peterburi tee 53
11415 Tallinn
Estonia

Phone: +372 680 7365
info@etsnord.ee
www.etsnord.ee

ETS NORD Finland

Address: Pakkasraitti 4
04360 Tuusula
Finland

Phone: +358 401 842 842
info@etsnord.fi
www.etsnord.fi

ETS NORD Sweden

Address: Järsjögatan 7
69235 Kumla
Sweden

Phone: +46 19 554 20 50

Address: Pinjegatan 5
21363 Malmö
Sweden

Phone: +46 40 94 68 70
info@etsnord.se
www.etsnord.se



Let's move the air together!