

KRI Damper with flow meter

KRI is an iris-type damper for measuring and regulating air flow.

Air flow measuring and regulating is done easily by using measuring nozzles and turning the regulating bolt, which turns the blades. See: Measuring and regulating air flows.

By opening the blades a full access to the system is provided for cleaning.

Tightness class EN 1751, class C.

Structure and dimensions

The damper and blades are manufactured of galvanized steel. Regulating bolt, regulating graph and measuring nozzles are made of plastic. Duct connections with rubber gaskets. Measuring nozzles on both sides of the blades. Can be operated in 80°C and momentarily in 120°C.



Nominal size, Ød mm	ØD mm	l mm	L mm	Weight, kg
KRI 100	160	60	115	0,6
KRI 125	185	60	110	0,7
KRI 160	225	60	115	1,0
KRI 200	280	65	120	1,4
KRI 250	330	75	135	1,9
KRI 315	405	75	135	2,5
KRI 400	525	55	190	6,4
KRI 500	655	70	170	9,6
KRI 630	815	70	170	15,6
KRI 800	1015	70	270	25,0

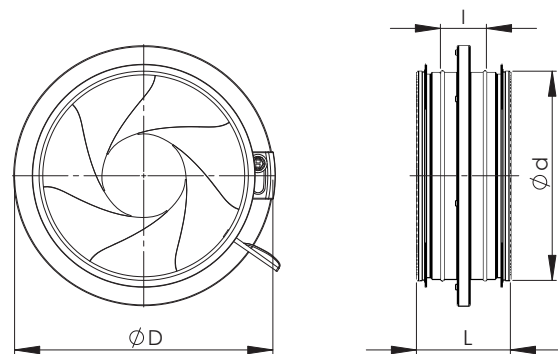

Technical data

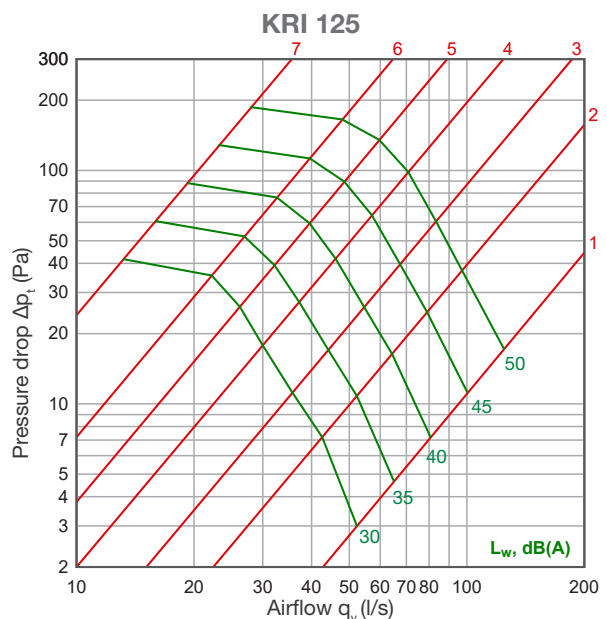
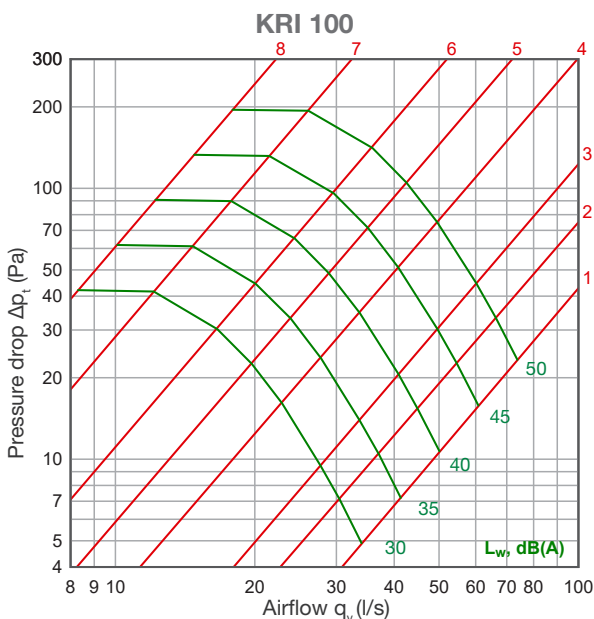

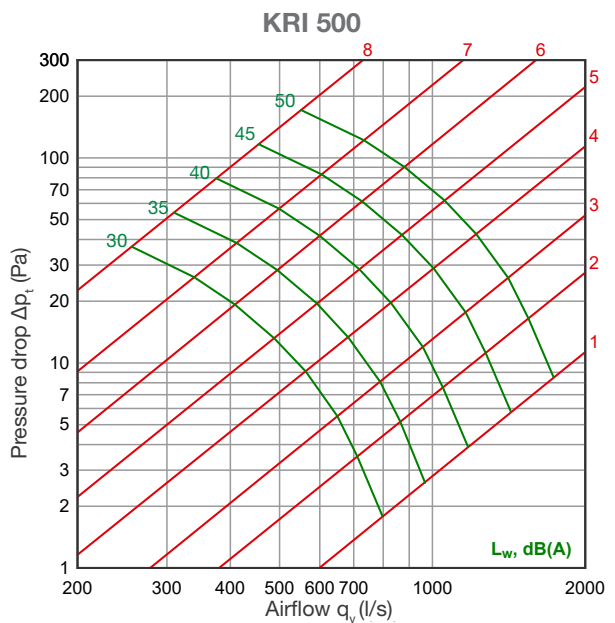
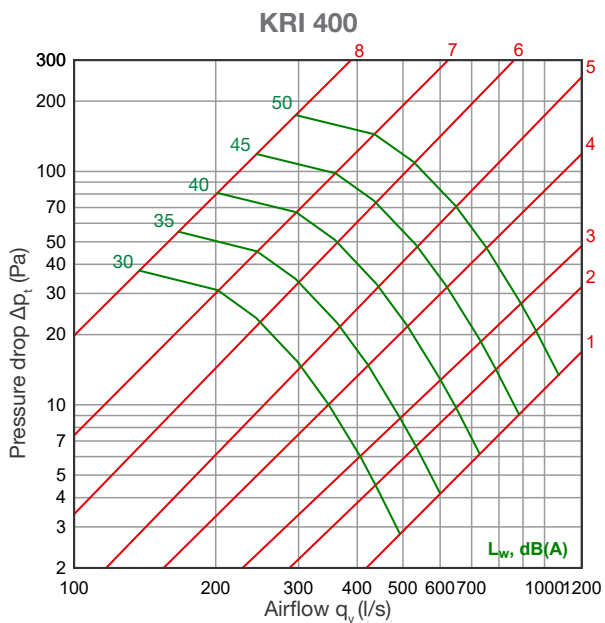
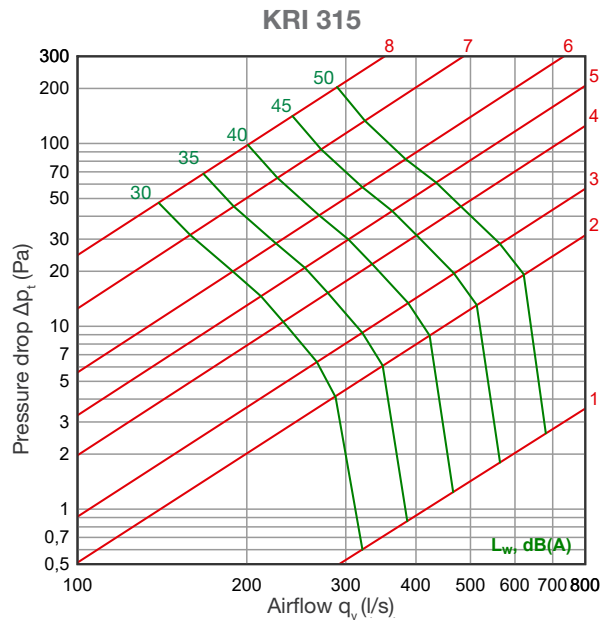
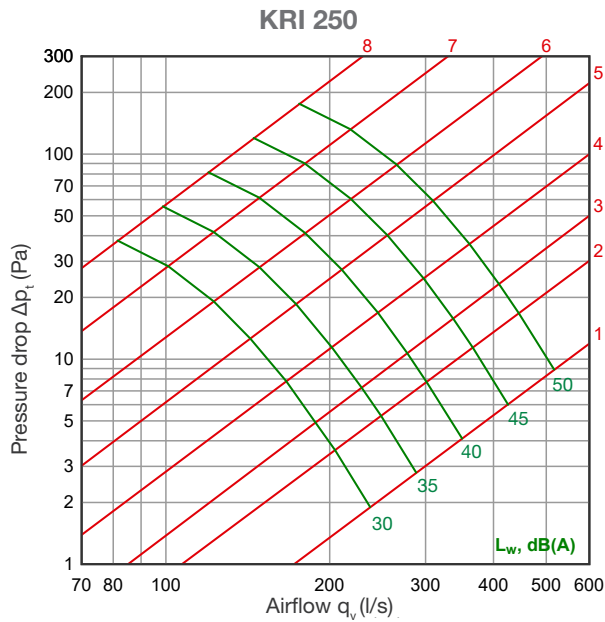
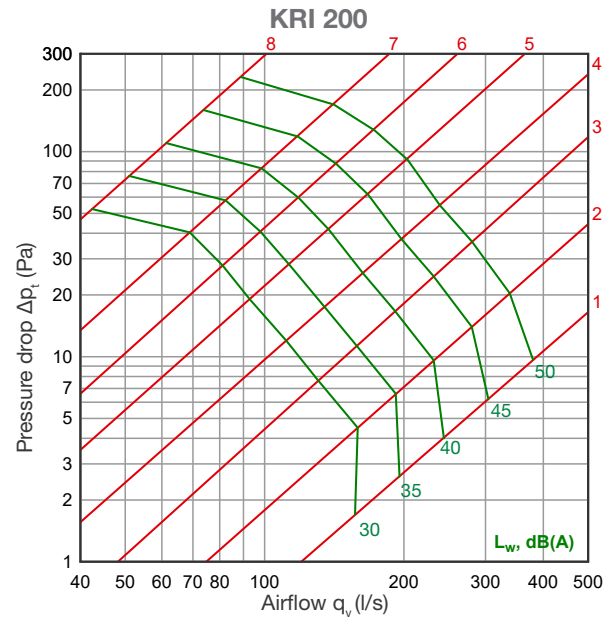
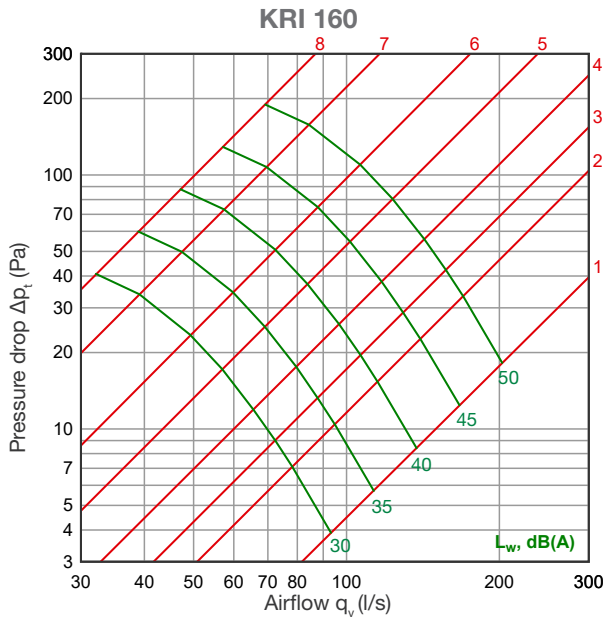

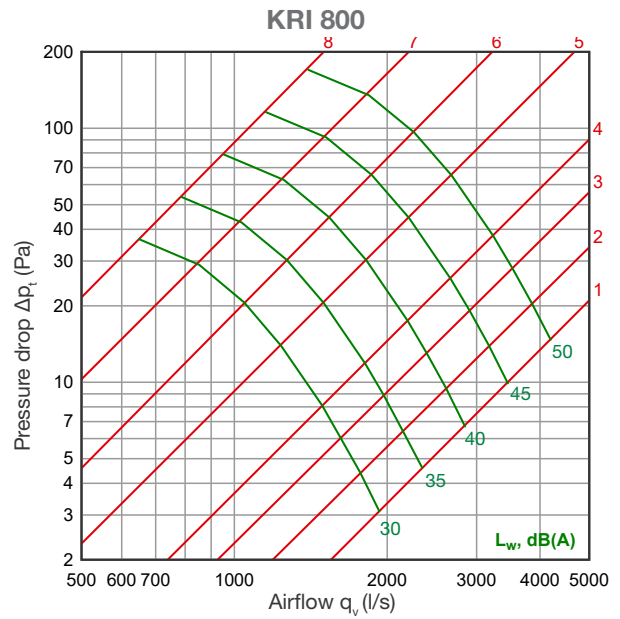
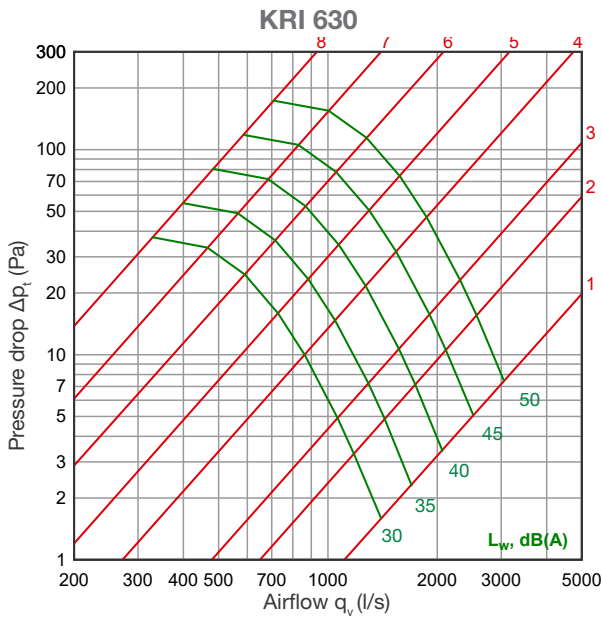

Sound power level L_w

	Correction of sound level K_{okt} [dB]							
	63	125	250	500	1000	2000	4000	8000
KRI 100	8	7	4	-3	-8	-15	-18	-25
KRI 125	9	7	3	-3	-8	-13	-18	-24
KRI 160	11	9	4	-3	-9	-12	-18	-25
KRI 200	14	9	3	-3	-9	-11	-18	-25
KRI 250	16	10	2	-4	-8	-12	-21	-26
KRI 315	19	10	2	-5	-7	-14	-23	-26
KRI 400	19	8	2	-3	-8	-15	-22	-26
KRI 500	19	6	3	-2	-9	-15	-20	-25
KRI 630	20	8	2	-3	-9	-15	-20	-26
KRI 800	21	9	2	-4	-10	-15	-20	-27
Tolerance ±	4	4	4	4	4	4	4	4

The sound power levels of the duct for every octave band are obtained by adding the corrections K_{okt} of octave bands (see table above) to the total sound pressure level L_{p10A} , dB(A), according to the following formula:

$$L_{Wokt} = L_{p10A} + K_{okt}$$

Correction K_{okt} is the average in the range of use of the regulation and measuring device.

Data for smoke restriction

KRI-100 and KRI-125 meet the requirements of RakMK E7:2004 for dampers (42 dm³/s, 100 Pa), when KRI-100 regulation value ≥ 6,0 and KRI-125 regulation value ≥ 5,5.

Marking

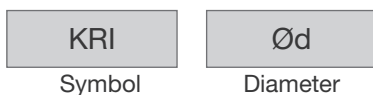

Example: KRI 100

Installation

KRI damper is installed as other parts and secured with rivets. See NORDDuct installation instructions. When installing you should be followed the required safety distance and right mounting distance. In the vertical duct system duct must be supported in order to avoid compression of the damper..

The specific situation

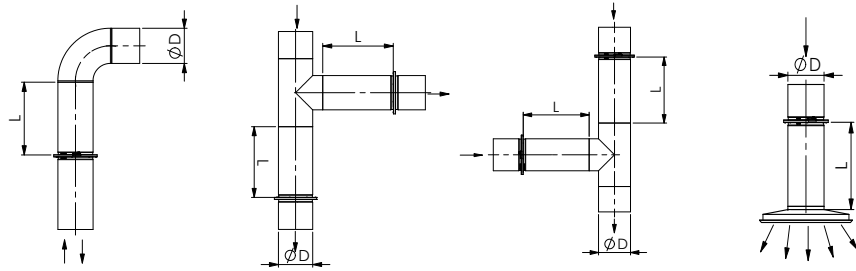

The required safety distance L
Method error $\pm 7\%$

$L \geq 1D$

$L \geq 4D$

$L \geq 2D$

$L \geq 2D$

Measuring and regulation

Air flow is calculated using the measuring diagram. By measuring the pressure difference between the measure nozzles, you can read the air flow from the diagram. Air flow is regulated by turning the regulating bolt.

The measuring diagram follows the product. N.B. The diagrams in this manual consider the technical data of the damper itself, and cannot be used for measuring air flows.

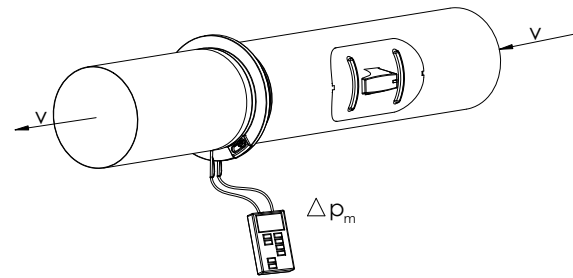

Cleaning

Note the regulation data. By fully opening the damper, one gets access to the duct. Do not forget to readjust the damper after cleaning.

