



NORDfire

FDMA-PM Fire Damper

Round fire dampers \varnothing 900-1000

CE certified acc. to EN15650

Fire resistance up to EIS 120

External Casig leakage class C, Internal leakage class 2 acc. to EN 1751

Damper actuating mechanical, or electrical

Corrosion resistant according to EN 15650

Cycling test in class C 10 000 according to EN 15650

Maximum air speed through opened damper of 12 m/s and pressure difference 1200 Pa

Option for explosion hazard environments available

General information

1. Description

1.1 Fire dampers are shutters in ducts of air-conditioning devices that prevent spreading the fire and combustion products from one fire segment to the other one by means of closing the duct in the points of fire separating constructions.

The damper blade automatically closes the air duct using a shutting spring or an actuating mechanism of back spring. The shutting spring is activated by pressing the start button or by the impulse from the thermal fuse. The back spring of the actuating mechanism is started when the thermoelectric starting mechanism BAT is activated, when the reset button on BAT is pressed or when the power supply to the actuating mechanism is stopped.

After closing the blade, the damper is sealed with a silicon packing against smoke penetration. The damper can be delivered with a seal without silicone at the customer's wish. At the same time, the damper blade is embedded in a material which enlarges its volume due to increasing temperature and hermetically seals the air duct.

The dampers have one inspection hole, as the shutting device and the inspection hole can be set to the most advantageous position with respect to operation and handling of the control device by turning the damper a little in case of the spiro model of the dampers.



Fig.1 FDMA-PM with actuating mechanism



Fig. 2 FDMA-PM with mechanical control

1.2 Damper characteristics

- CE certified acc. to EN 15650
- Tested in accordance with EN 1366-2
- Classified acc. to EN 13501-3+A1
- Fire resistance EIS 120, EIS 90
- External Casing leakage class C, Internal leakage class 2 acc. to EN 1751
- Cycling test in class C 10000 acc. to EN 15650
- Corrosion resistant acc. to EN 15650
- ES Certificate of conformity No. 1391-CPR-2016/0158
- Declaration of Performance No. PM/FDMA-PM/01/20/1
- Hygienic assessment of fire dampers - Report No. 1.6/pos/19/19b

1.3 Working conditions

Right damper function is secured under the following conditions:

- a) Maximum air circulation speed: 12 m/s
Maximum pressure difference: 1200 Pa
- b) The air circulation in the whole damper section must be secured as steady on whole surface.

Operation of the dampers does not depend on the direction of air circulation. The dampers can be located in an arbitrary position.

Dampers are suitable for systems without abrasive, chemical and adhesive particles.

Dampers are designed for macroclimatic areas with mild climate according to EN 60 721-3-3.

Temperature in the place of installation is permitted to range from -30°C to +50°C.

2. Design

2.1 Design with mechanical control

Design .01

Design with mechanical control with a thermal protective fuse which actuates the shutting device, after the nominal start temperature 72°C has been reached. Automatic initiation of the shutting device is not activated if the temperature does not exceed 70°C. In case that other start temperatures are required, thermal fuses with nominal start temperature +104°C or +147°C can be supplied (this requirement must be specified in the order).

Fig. 3 Design .01



Design .11

Design .01 with mechanical control can be complemented with a limit switch signalling of the damper blade position "CLOSED". Cable is connected directly to limit switch.

Fig. 4 Design .11

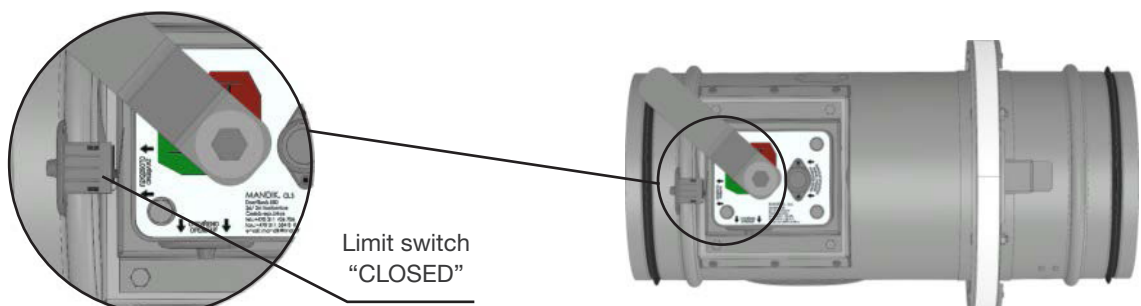

Design .80

Design .01 with mechanical control can be complemented with a terminal switches signaling of the damper blade position “CLOSED” and “OPEN”. Limit switches are connected via damper casing, cables are connected directly to limit switches.

Fig. 5 Design .80

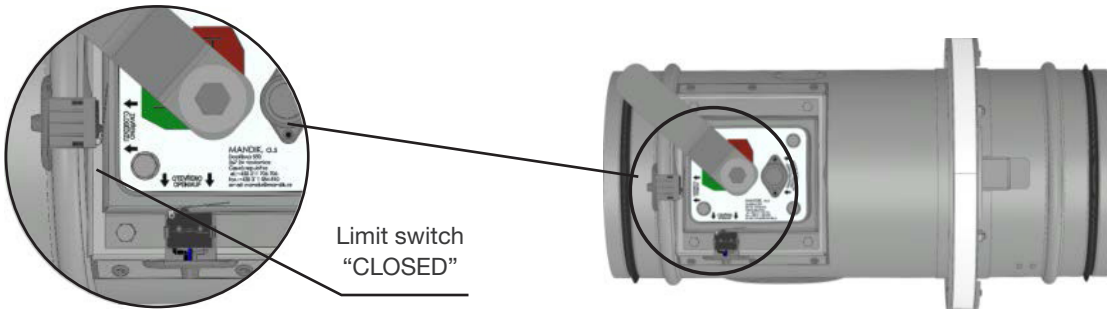
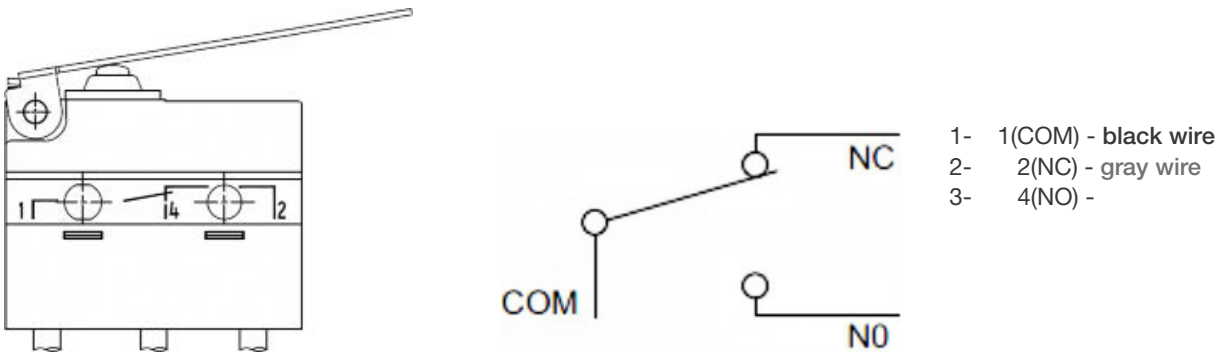

Fig. 6 Limit switch G905-300E03W1



Nominal voltage and maximal current	AC 230 V / 5A
Class of protection	IP 67
Working temperature	-25 °C...+120 °C

This limit switch is possible to connect in following two versions:

- a) **CUT-OFF** if the arm is moving ... connect wire 1+2
- b) **SWITCH-ON** if the arm is moving ... connect wire 1+4

Fig. 7 Change of mechanical design for the motorised one or vice versa

Position:

- 1- Damper
- 2- Mounting plate
- 3- Sealing cover
- 4- Seal plates
- 5- Mounting plate cover
- 6- Thermal fuse
- 7- Mechanics
- 8- Actuator
- 9- Temperature sensor
- 10- Sensor sticker

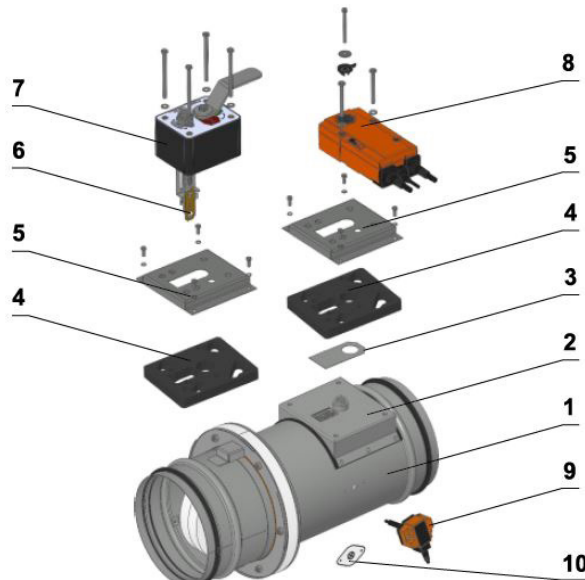

2.2 Design with actuating mechanism

Design .40, .50

The dampers are equipped with Belimo actuating mechanisms with back spring and thermoelectric actuating device, of range BF (hereinafter referred to only as the "actuating mechanism"). After being connected to power supply AC/DC 24V or AC 230V, respectively, the actuating mechanism moves the damper blade to "OPEN" operation position and at the same time pre-stretches its back spring. While the actuating mechanism is under voltage, the damper blade is in the "OPEN" position and the back spring is pre-stretched. The time needed for full opening of the damper blade from "CLOSED" position to "OPEN" position is 120 seconds at the maximum. If the power supply to the actuating mechanism is cut off (due to loss of power supply or by pressing the reset button on the BAT thermoelectric starting mechanism), the back spring will move the damper blade to "CLOSED" failure position. The time of moving the blade from "OPEN" position to "CLOSED" position takes 20 seconds at the maximum. If the power supply is restored (the blade can be in any position), the actuating mechanism starts to move the damper blade to "OPEN" position again. A thermoelectrical starting mechanism BAT, which contains two thermal fuses Tf1 and Tf2, is a part of the actuating mechanism. These fuses are activated when temperature +72°C has been exceeded (the fuse Tf1 when the temperature around the damper and the fuses Tf2 when the temperature inside the air-conditioning piping has been exceeded). After the thermal fuse Tf1 or Tf2 has been activated, the power supply is permanently and irreversibly cut off and the actuating mechanism, by means of the pre-stretched spring, displaces the damper blade into the breakdown position "CLOSED".

Signalisation of damper blade position "OPEN" and "CLOSE" is provided by two limit switches.

Fig. 8 Design .40, .50

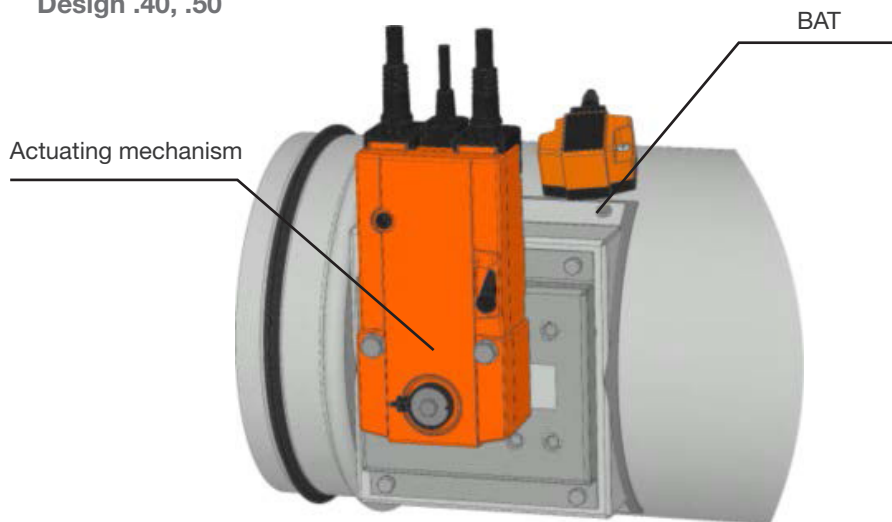
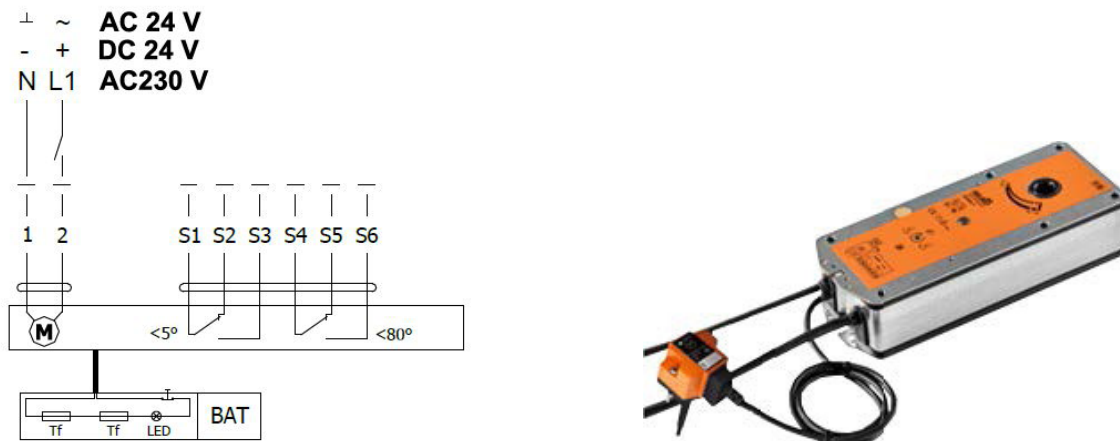

Fig. 9 Actuating mechanism BELIMO BF 230-TN, BF 24-TN (-ST)



Tab 2.2.1. Actuating mechanism BELIMO BF 24-TN(-ST), BF 230-TN

Actuating mechanism BELIMO	BF 24-TN(-ST)	BF 230-TN
Nominal voltage	AC 24 V 50/60 Hz DC 24 V	AC 230 V 50/60 Hz
Power consumption - motoring - holding	7 W 2 W	8 W 3 W
Dimensioning	10 VA (I _{max} 8,3 A @ 5 ms)	12,5 VA (I _{max} 500 mA @ 5 ms)
Protection class	III	II
Degree of protection	IP 54	
Running time - motor - spring return	120 sec ~ 16 sec	
Ambient temperature - normal duty - safety duty - non-operating temperature	- 30°C ... +55°C The safe position will be attained up to max. +75°C - 40°C ... +55°C	
Connecting - motor - auxiliary switch	cable 1 m, 2 x 0,75 mm ² cable 1 m, 6 x 0,75 mm ² (BF 24-T-ST) with plug-in connectors	
Thermal trips	Tf1: duct outside temperature Duct +72°C Tf2/Tf3: duct inside temperature Duct +72°C	

3. Dimensions, weighs and effective area

3.1 Dimensions

Fig. 10 Design with mechanical control

Position:

- 1- Damper casing
- 2- Mechanics
- 3- Damper blade
- 4- Inspection hole covering
- 5- Sensor sticker
- 6- Hole for camera

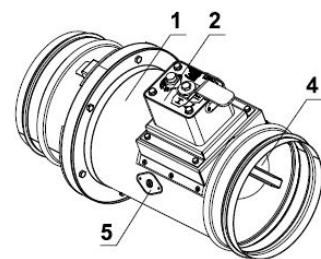
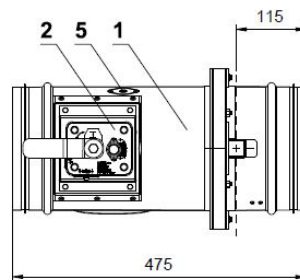
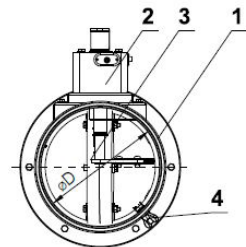
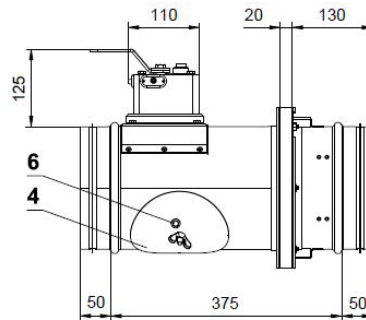
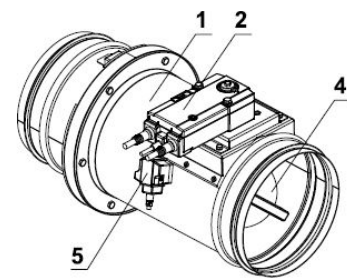
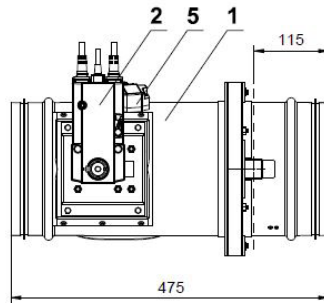
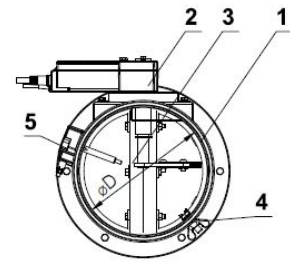
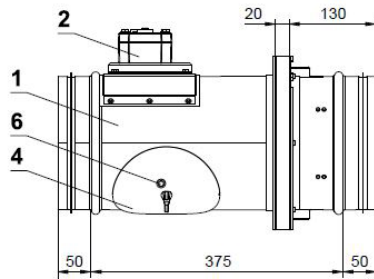

Fig. 11 Design with actuating mechanism

Position:

- 1- Damper casing
- 2- Mechanics
- 3- Damper blade
- 4- Inspection hole covering
- 5- BAT thermoelectrical starting mechanism
- 6- Hole for camera



3.2 Weights and effective area

Tab 3.2.1. Dampers SPIRO

Nominal size ØD [mm]	g [mm]	h [mm]	Weight		Effective area S_{ef} [m ²]	Actuating mechanism	Mechanical control
			Design				
			manual [kg]	act.mech. [kg]			
900	84,5	326,5	53,0	56,0	0,5727	BF	M4
1000	134,5	376,5	70,9	73,9	0,7147	BF	M4

Tab 3.2.2. Dampers with flanges

Nominal size ØD [mm]	g [mm]	h [mm]	Weight		Effective area S_{ef} [m ²]	Actuating mechanism	Mechanical control
			Design				
			manual [kg]	act.mech. [kg]			
900	134,5	376,5	56,0	59,0	0,5727	BF	M4
1000	184,5	426,5	74,0	77,0	0,7147	BF	M4

3.3 Blades overlaps

Tab 3.3.1. Blades overlaps

Blades overlaps		Dimension	Overlaps
DAMPERS SPIRO Fig.26	Act. mechanism side	"g"	Tab. 4.2.1
	Side without act.mechanism	"h"	
DAMPERS WITH FLANGES Fig.27	Act. mechanism side	"e"	Tab. 4.2.2
	Side without act. mechanism	"f"	

These values has to be respected when projecting related air-conditioning ducts.

Fig. 12 Blades overlaps SPIRO

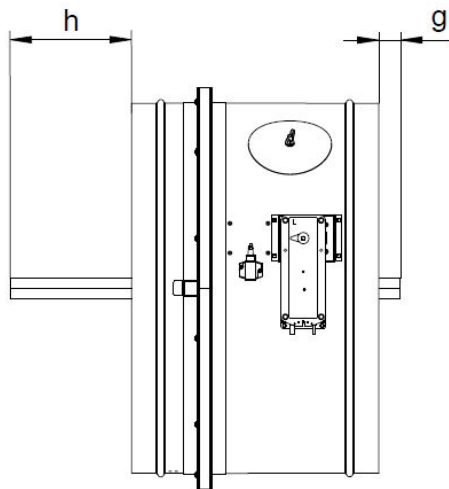

4. Placement and Assembly

- 4.1 The fire dampers are suitable for installation in arbitrary position in vertical and horizontal passages of fire separating structures. The damper assembly procedures must be done so that all load transfer from the fire separating constructions to the damper body is absolutely excluded. The back-to-back air-conditioning piping must be suspended or supported so that all load transfer from the back-to-back piping to the damper flanges is absolutely excluded. The gap between the installed damper and the building structure must be perfectly filled with approved material all over its volume. To provide the necessary space for access to the control device, all other items must be situated at least 350 mm from the control parts of the damper. At least one inspection hole must be accessible. The damper must be installed so that the damper blade (in closed position) is situated in the fire separating structure - marked by the label BUILD-IN EDGE on the damper body. If such solution is not possible, the piping between the fire separating structure and the damper blade must be protected according to the certified installation method, see Section 6. During the installation and plastering process, the control mechanism must be protected (covered) against damage and pollution. The damper body should not be deformed during bricking in. Once the damper is built in, the damper blade should not grind on the damper body during opening or closing. The distance between the fire damper and the structure (wall, ceiling) must be 75 mm at the minimum. If two or more dampers are to be installed in one fire separating structure, the distance between adjacent dampers must be 200 mm at the minimum, according to EN 1366-2 paragraph 13.5. For admissible exceptions see Section 6

Fig. 13 The distance between the fire damper and the construction

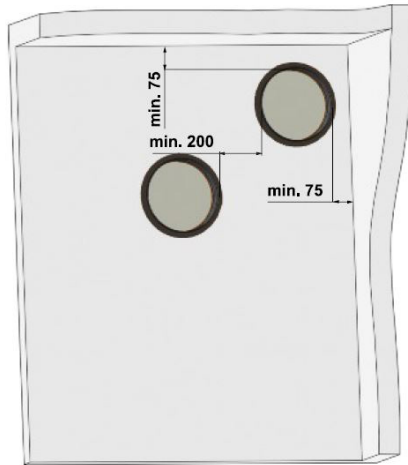
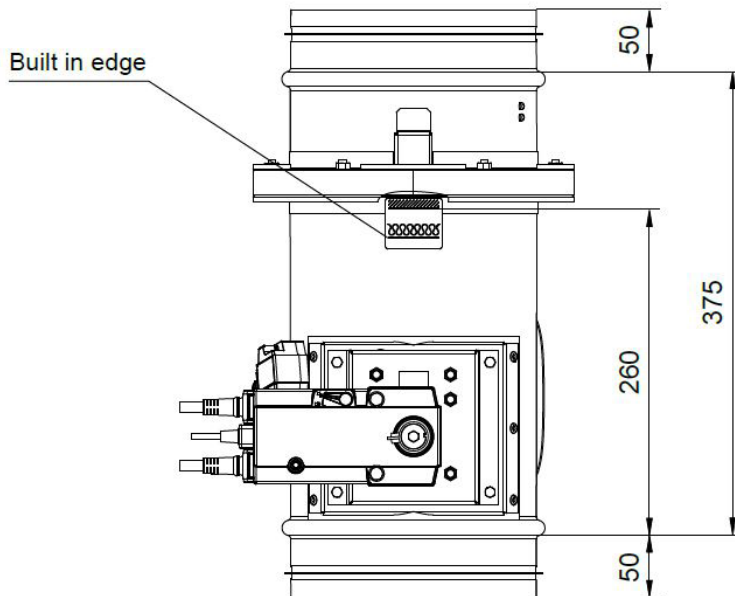

Fig. 14 Built in edge



The damper must be installed so that the entire damper blade - in the closed position - is located inside the fire separating structure (wall) and at the same time the control mechanism and inspection openings are freely accessible. „Built-in edge label” indicates the maximum edge of installation of fire damper into the fire partition structure.

Fig. 15 Installation opening

Installation opening- round damper

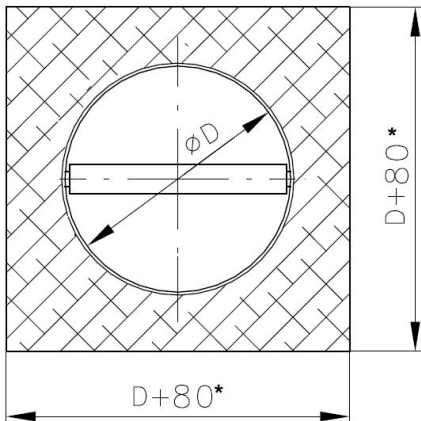

Installation opening- round damper

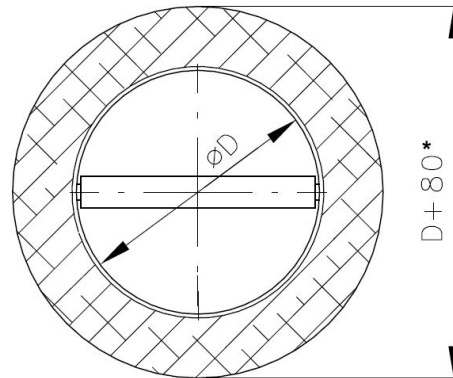

Installation opening- round damper Weichschott system

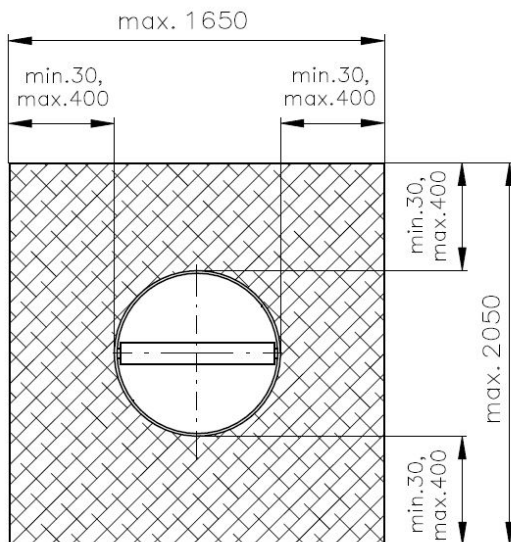

* For dampers with flanges is valid $D + 160$ mm

4.2 Examples of fire damper installing

The fire damper can be integrated into a solid wall construction made e.g. of normal concrete/ masonry, porous concrete with minimum thickness 100 mm or into solid ceiling construction made e.g. of normal concrete with minimum thickness 110 mm or porous concrete with minimum thickness 125 mm.

The fire damper can be integrated into a gypsum wall construction with fire classification EI 120 or EI 90.

5. Statement of installations

5.1 Installation method list

Tab 5.1.1.Installation method list

Fire separating constru.	Wall/Ceiling	Installation	Fire resist.	Page
	Min.thickness [mm]			
Solid wall construction	100	Mortar or gypsum	EIS 120 EIS 90	12
	100	Battery - mortar or gypsum	EIS 90	13
	100	Installation next to wall - mortar or gypsum and mineral wool	EIS 90	14
	100	Installation next to wall - mortar or gypsum	EIS 90	14
	100	Stuffing box with fire protection mastic and cement lime plate	EIS 90	15
	100	Weichschott	EIS 90	16
Outside solid wall construction	100	Mineral wool - mortar or gypsum	EIS 45	17
	100	Mineral wool - stuffing box and fire protection mastic	EIS 45	18
	100	Mineral wool, stuffing box, fire protection mastic and cement lime plate	EIS 90	19
Gypsum wall construction	100	Mortar or gypsum	EIS 120 EIS 90	20
	100	Battery - mortar or gypsum	EIS 90	21
	100	Installation next to wall - mortar or gypsum and mineral wool	EIS 90	22
	100	Installation next to wall - mortar or gypsum	EIS 90	22
	100	Stuffing box with fire protection mastic and cement lime plate	EIS 90	23
Outside gypsum wall construction	100	Mineral wool - mortar or gypsum	EIS 45	24
	100	Mineral wool - stuffing box and fire protection mastic	EIS 45	25
	100	Mineral wool, stuffing box, fire protection mastic and cement lime plate	EIS 90	26
Solid ceiling construction	110 - Concrete 125 - Aerated concrete	Mortar or gypsum	EIS 120 EIS 90	27
		Battery - mortar or gypsum	EIS 90	28
		Stuffing box with fire protection mastic and cement lime plate	EIS 90	29
		Weichschott	EIS 90	30
		Mineral wool - mortar or gypsum	EIS 90	31
Outside solid ceiling construction		Concrete	EIS 90	32

5.2 Installation in solid wall construction

Fig. 16 Solid wall construction- mortar or gypsum

EIS 120

EIS 90

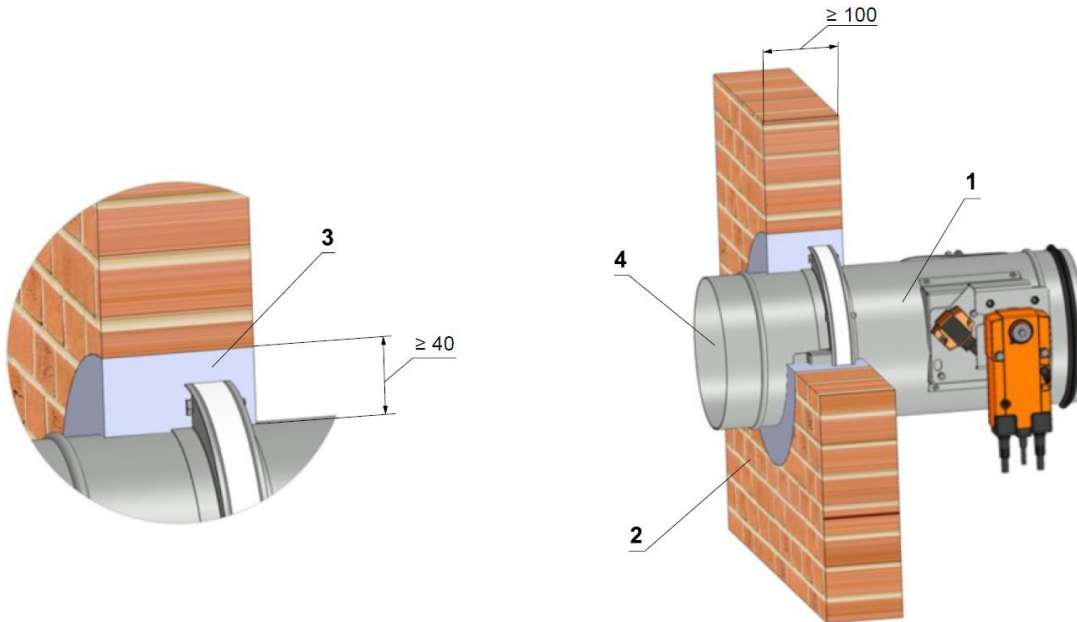

Position:

- 1 Fire damper
- 2 Solid wall construction
- 3 Mortar or gypsum
- 4 Duct

Shown schemes of incorporation and damper are illustrative only!

Fig. 17 Solid wall construction- battery- mortar or gypsum

EIS 90

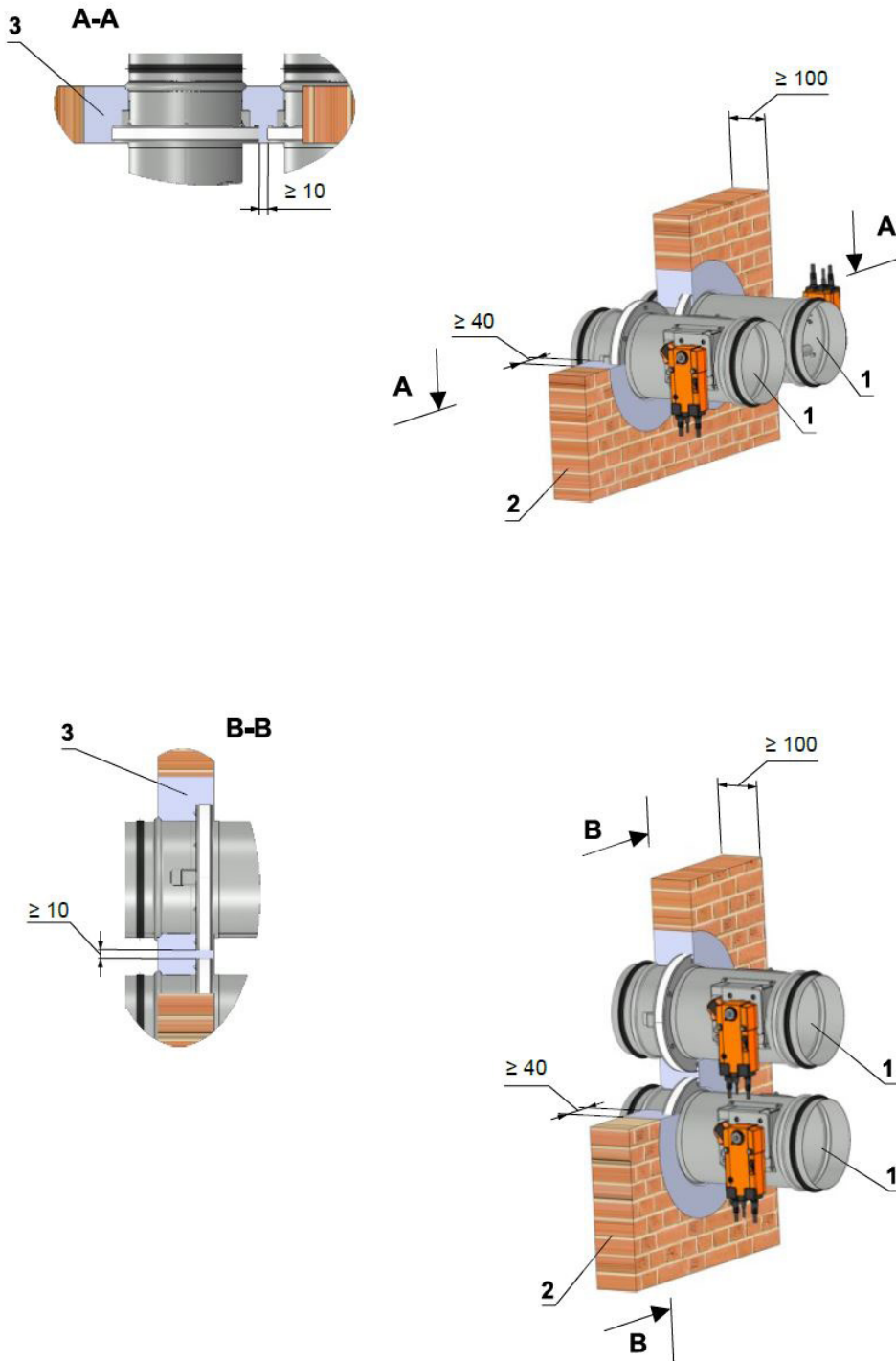

Position:

- 1 Fire damper
- 2 Solid wall construction
- 3 Mortar or gypsum

Notice:

- Installation opening for each damper has minimal dimensions
- D+80 mm (D+160 mm for dampers with flanges)
- Gap between damper and construction is filled by mortar or gypsum
- Distance between dampers 70 mm
- Flange to flange connection - Up to four dampers can be installed

Shown schemes of incorporation and damper are illustrative only!

Fig. 18 Solid wall construction- installation next to wall, ceiling- mortar or gypsum and mineral wool EIS90

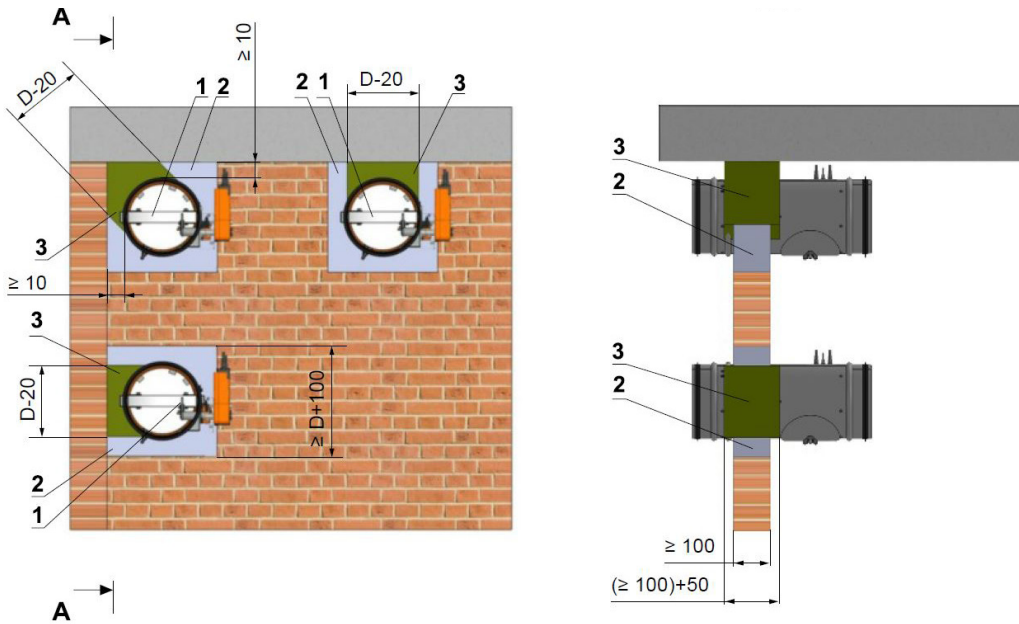

Position:

- 1 Fire damper
- 2 Mortar or gypsum
- 3 Stuffing box (mineral stone wool min. density 140 kg/m^3)

Notice:

- Gap between damper and construction is filled by mortar or gypsum and mineral wool
- Wool is fixed to damper body and construction by fire protection mastic.
- Mineral wool thickness = construction thickness + 20 mm or 50 mm
- Installation is valid for ceiling construction

Shown schemes of incorporation and damper are illustrative only!

Fig. 19 Solid wall construction- installation next to wall, ceiling- mortar or gypsum EIS90

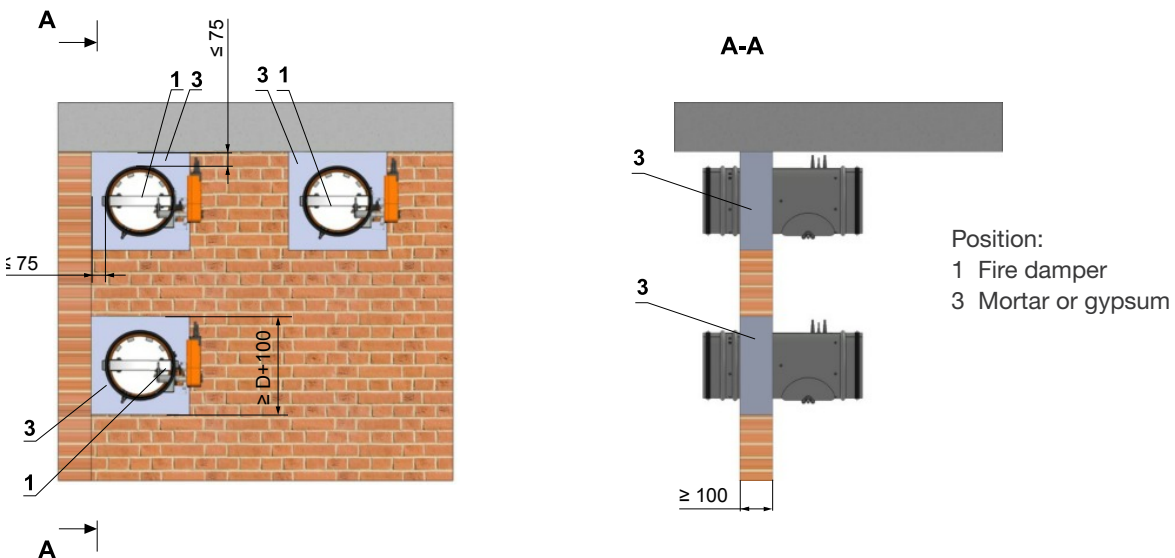

- Position:
- 1 Fire damper
 - 3 Mortar or gypsum

Notice:

- Installation is valid for ceiling construction

Shown schemes of incorporation and damper are illustrative only!

Fig. 20 Solid wall construction- stuffing box, fire protection mastic and cement lime plate

EIS 90

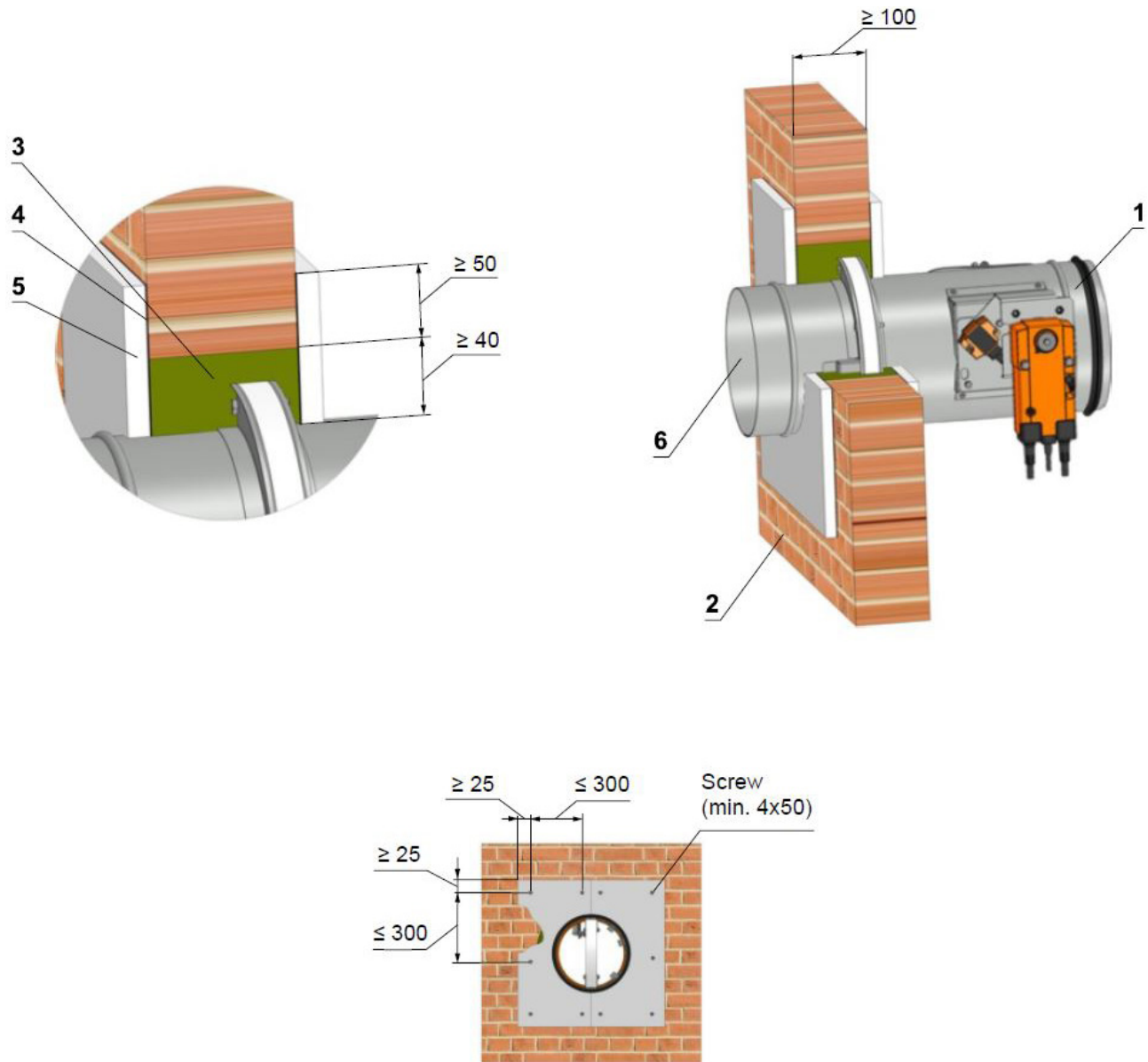

**Screws has to be fixed in wall/ceiling construction.
(If it is needed use steel bracket).**

Position:

- 1 Fire damper
- 2 Solid wall construction
- 3 Stuffing box (mineral stone wool min. density 140 kg/m³)
- 4 Fire protection mastic min. thickness 1 mm
- 5 Cement lime plate min. thickness 15 mm min. density 870 kg/m³
- 6 Duct

* Fire resistant insulation and fire resistant board can be replaced by another approved fire sealing system for damper installation with equivalent material properties.

**The damper must be anchored to the fire wall construction!
Shown schemes of incorporation and damper are illustrative only!**

5.3 Installation in solid ceiling construction

Fig. 21 Outside solid wall construction- mineral wool- mortar or gypsum

EIS 45

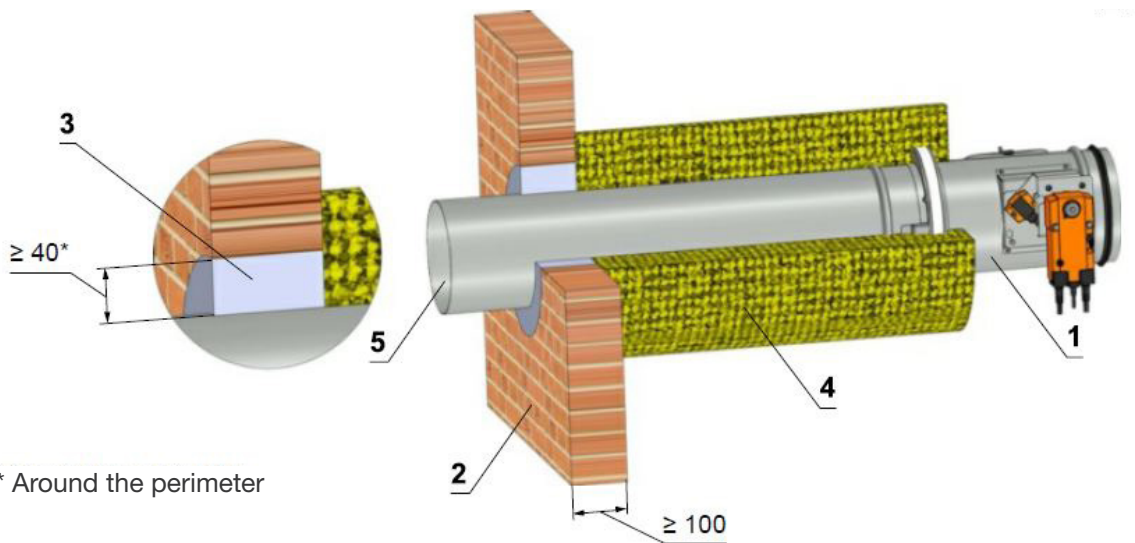

* Around the perimeter

Position:

- 1 Fire damper
- 2 Solid wall construction
- 3 Mortar or gypsum
- 4 Stone wool with wired mat on one side, density 66 kg/m³
- 5 Duct

Used materials - example:**

- 4 Isover Ultimate Protect Wired MAT 4.0, th. 100 mm ALU1

** The materials for stuffing box, fire protection mastic, lining and insulation materials can be replaced by another approved fire sealing system with equivalent properties.

The maximum distance of the fire damper from the structure is not limited and according to EN 15882-2, the required number of suspensions acc. to EN 1366-1:2014 must be used.

**The duct at the point of penetration can be anchored to the fire wall construction!
Shown schemes of incorporation and damper are illustrative only!**

Fig. 22 Outside solid ceiling construction- mineral wool- stuffing box and fire protection mastic

EIS 45

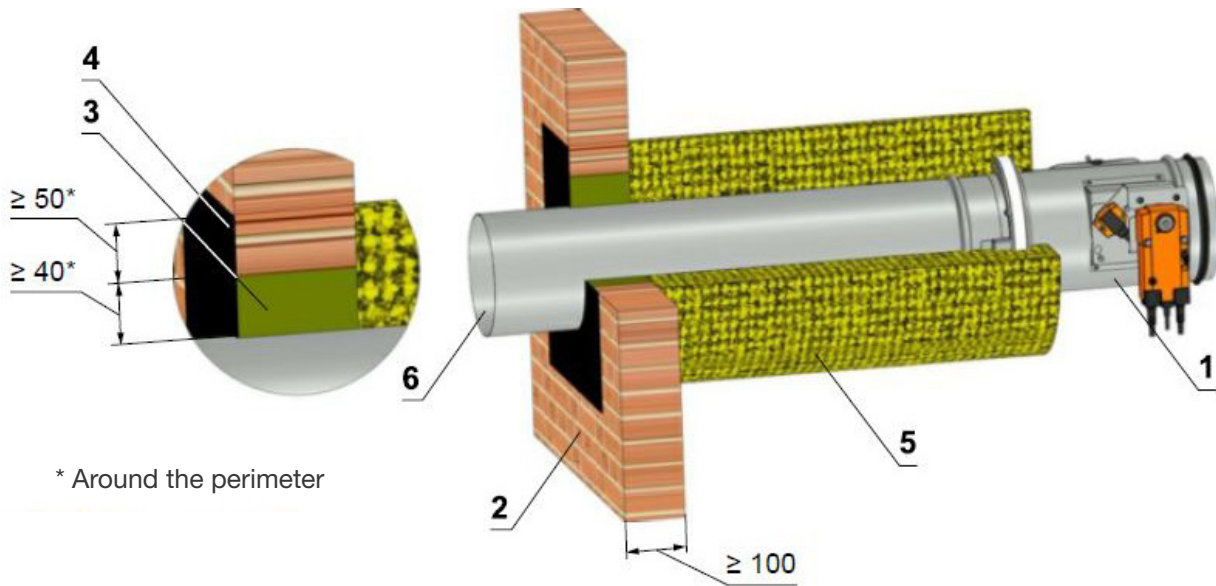

Position:

- 1 Fire damper
- 2 Solid wall construction
- 3 Mineral stone wool min.density 150 kg/m³
- 4 Fire protection mastic min.thickness 1 mm
- 5 Stone wool with wired mat on one side, density 66 kg/m³
- 6 Duct

Used materials - example:**

- 3 Promapyr, Rockwool Steprock HD, Hilti CFS-CT B 1S 140/50
- 4 Promastop - P, K, Hilti CFS-CT
- 5 Isover Ultimate Protect Wired MAT 4.0, th. 100 mm ALU1

** The materials for stuffing box, fire protection mastic, lining and insulation materials can be replaced by another approved fire sealing system with equivalent properties.

The maximum distance of the fire damper from the structure is not limited and according to EN 15882-2, the required number of suspensions acc. to EN 1366-1:2014 must be used.

**The duct at the point of penetration can be anchored to the fire wall construction!
Shown schemes of incorporation and damper are illustrative only!**

Fig. 23 Outside solid ceiling construction- mineral wool- stuffing box, fire protection mastic and cement lime plate

EIS 90

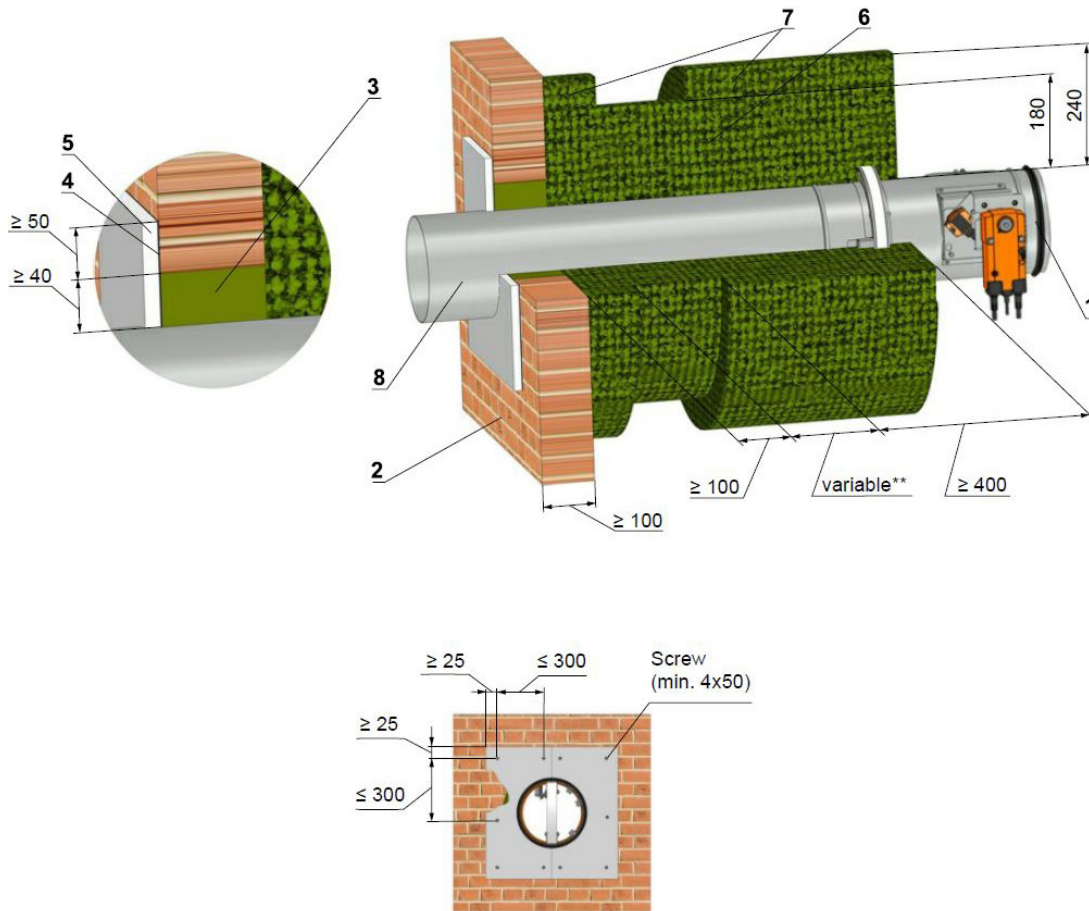

**Screws has to be fixed in wall/ceiling construction.
(If it is needed use steel bracket).**

Position:

- 1 Fire damper
- 2 Solid wall construction
- 3 Stuffing box
(mineral stone wool min. density 140 kg/m³)
- 4 Fire protection mastic min. thickness 1 mm
- 5 Cement lime plate min. thickness 15 mm
(min. density 870 kg/m³)
- 6 Stone wool with one side stitched wire fencing
(min. density 105 kg/m³), thickness 180 mm
(e.g. 3x60 mm)
- 7 Stone wool with one side stitched wire fencing
(min. density 105 kg/m³), thickness 60 mm
- 8 Duct

Used materials - example:*

- 3 Promapyr, Rockwool Steprock HD, Hilti CFS-CT B 1S 140/50
- 4 Promastop - P, K, Hilti CFS-CT
- 5 Promatect - H
- 6 Rockwool Wired Mat 105 th. 3x60 mm
- 7 Rockwool Wired Mat 105 th. 60 mm

* Stuffing box, fire protection mastic, cement lime plate and insulation materials can be replaced by another approved fire sealing system for damper installation with equivalent material properties.

** Depends on the distance of the flap from the construction, when the maximum distance from the construct is not limited and according to EN 15882-2 must use the required number of hinges according to EN 13366-1:2014.

**The duct at the point of penetration can be anchored to the fire wall construction!
Shown schemes of incorporation and damper are illustrative only!**

5.4 Installation in solid ceiling construction

Fig. 24 Gypsum wall construction- mortar or gypsum

EIS 120

EIS 90

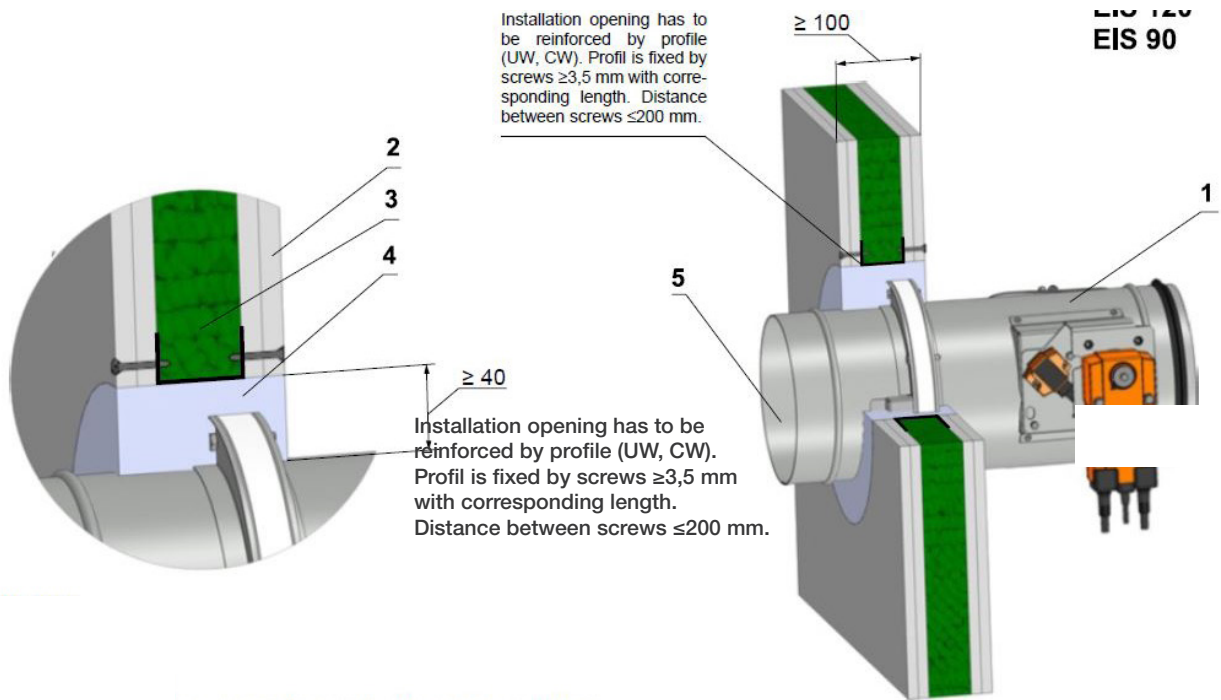

Position:

- 1 Fire damper
- 2 Gypsum plate
- 3 Mineral wool (type depending on the type of construction)
- 4 Mortar or gypsum
- 5 Duct

Shown schemes of incorporation and damper are illustrative only!

Fig. 25 Gypsum wall construction- Battery- mortar or gypsum

EIS 90

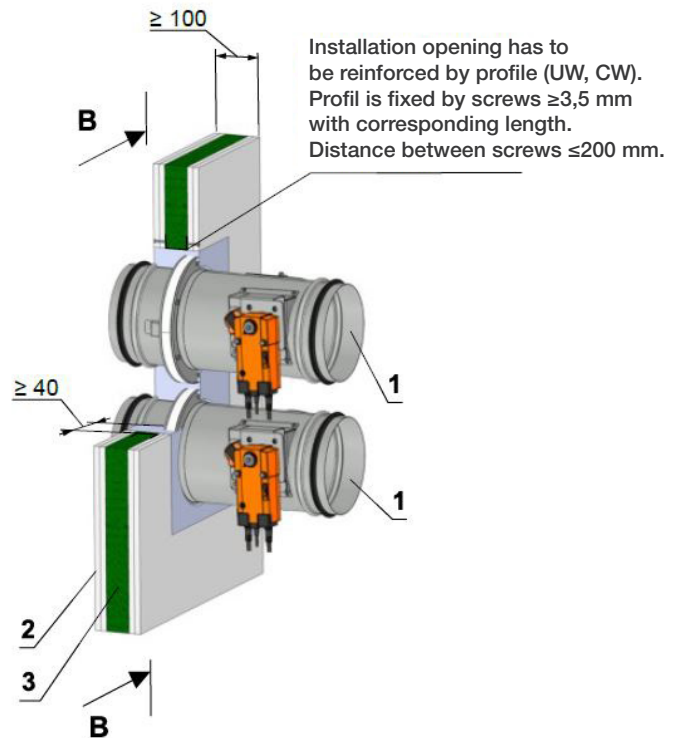
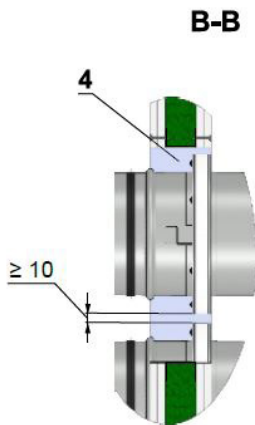
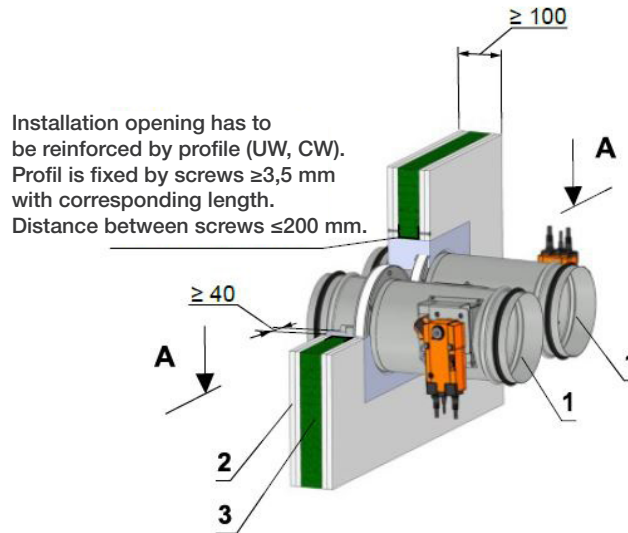
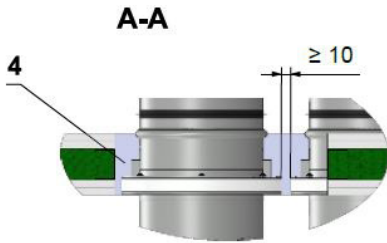

Position:

- 1 Fire damper
- 2 Gypsum plate
- 3 Mineral wool
(type depending on the type of construction)
- 4 Mortar or gypsum

Notice:

- The installation opening for each fire damper has a minimum size of $a \times b = (D + 97+3 \text{ mm}) + 20 \text{ mm} \times (D + 97+3 \text{ mm})$ or $a \times b = (D + 97+3 \text{ mm}) \times (D + 97+3 \text{ mm}) + 20 \text{ mm}$
- Gap between damper and construction is filled by mortar or gypsum
- Distance between dampers 70 mm
- Flange to flange connection - Up to four dampers can be installed

Shown schemes of incorporation and damper are illustrative only!

Fig. 26 Gypsum wall construction- installation next to wall, ceiling- mortar or gypsum and mineral wool

EIS 90

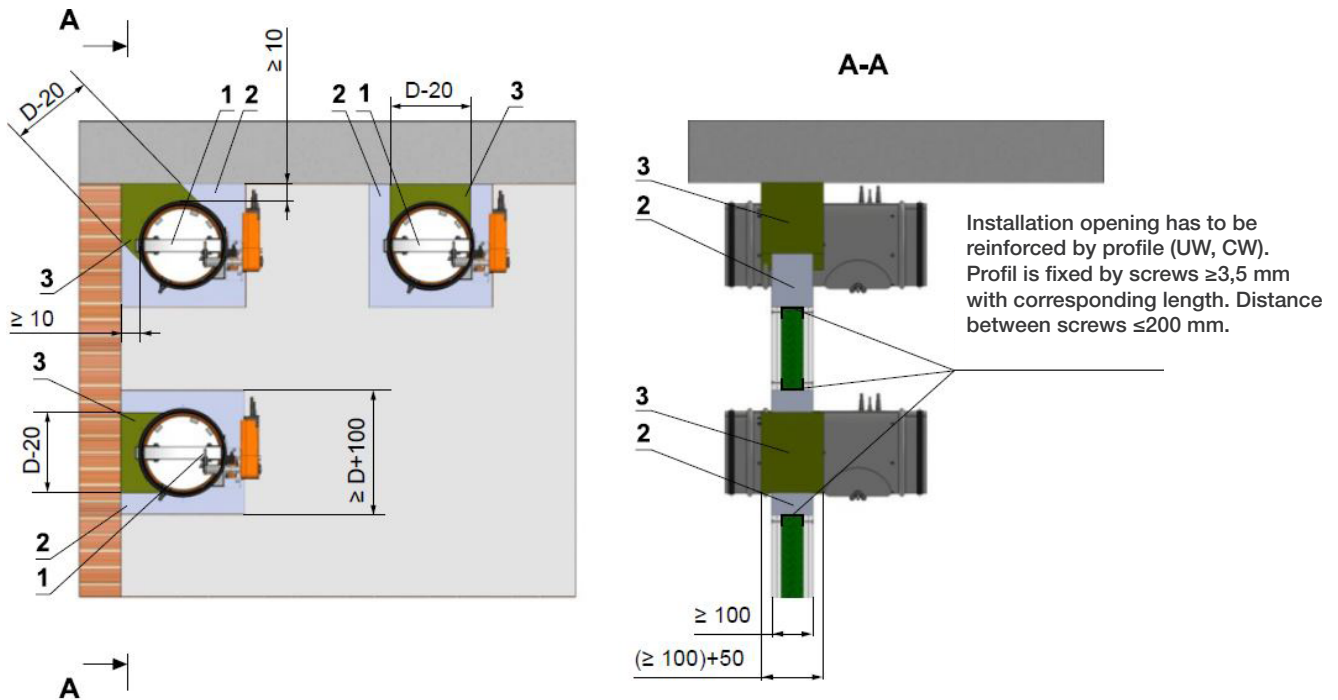

Position:

- 1 Fire damper
- 2 Mortar or gypsum
- 3 Stuffing box (mineral stone wool min. density 140 kg/m³)

Notice:

- Gap between damper and construction is filled by mortar or gypsum and mineral wool
- Wool is fixed to damper body and construction by fire protection mastic.
- Mineral wool thickness = construction thickness + 20 mm or 50 mm
- Installation is valid for ceiling construction

Shown schemes of incorporation and damper are illustrative only!

Fig. 27 Gypsum wall construction- installation next to wall, ceiling- mortar or gypsum

EIS 90

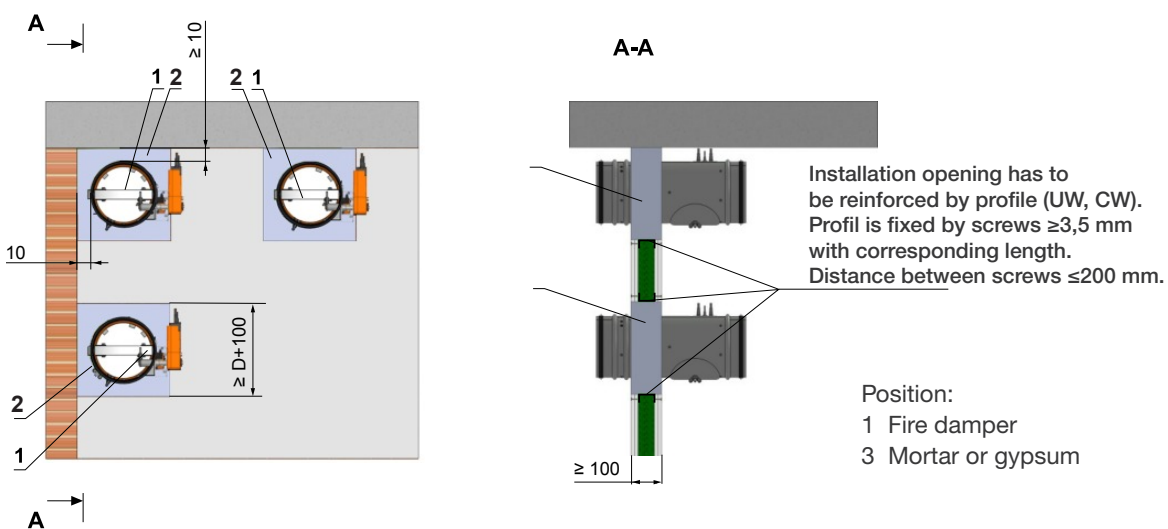

Position:

- 1 Fire damper
- 3 Mortar or gypsum

Notice:

- Installation is valid for ceiling construction

Shown schemes of incorporation and damper are illustrative only!

Fig. 28 Gypsum wall construction- stuffing box, fire protection mastic and cement lime plate

EIS 90

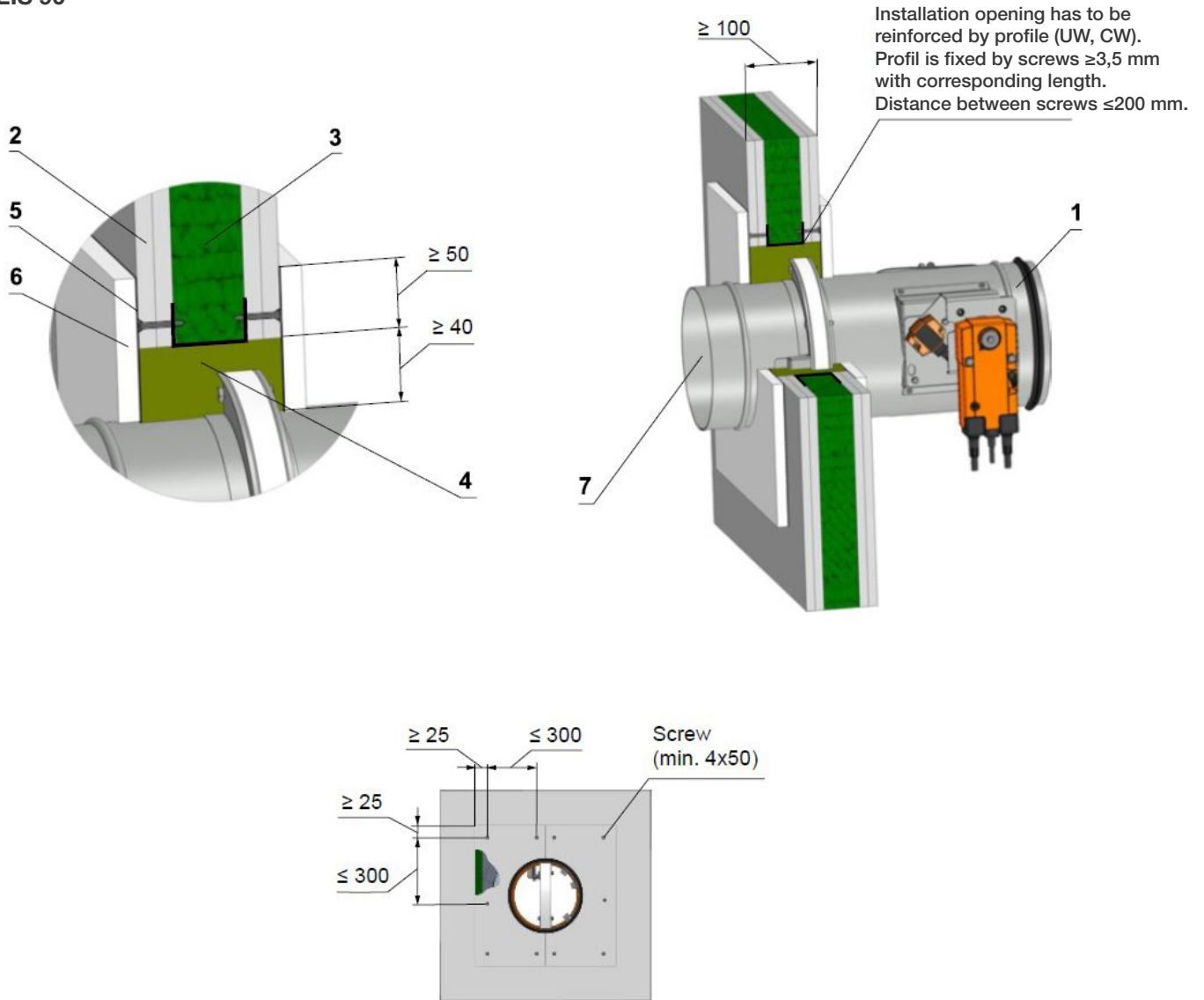

**Screws has to be fixed in wall/ceiling construction.
(If it is needed use steel bracket).**

Position:

- 1 Fire damper
- 2 Gypsum plate
- 3 Mineral wool
(type depending on the type of construction)
- 4 Stuffing box
(mineral stone wool min. density 140 kg/m³)
- 5 Fire protection mastic min. thickness 1 mm
- 6 Cement lime plate min. thickness 15 mm
(min. density 870 kg/m³)
- 7 Duct

Used materials - example:*

- 3 Promapyr, Rockwool Steprock HD,
Hilti CFS-CT B 1S 140/50
- 4 Promastop - P, K, Hilti CFS-CT
- 5 Promatect - H

* Fire resistant insulation and fire resistant board can be replaced by another approved fire sealing system for damper installation with equivalent material properties.

The damper must be anchored to the fire wall construction!

Shown schemes of incorporation and damper are illustrative only!

5.5 Installation outside gypsum wall construction

Fig. 29 Outside gypsum wall construction- mineral wool- mortar and gypsum

EIS 45

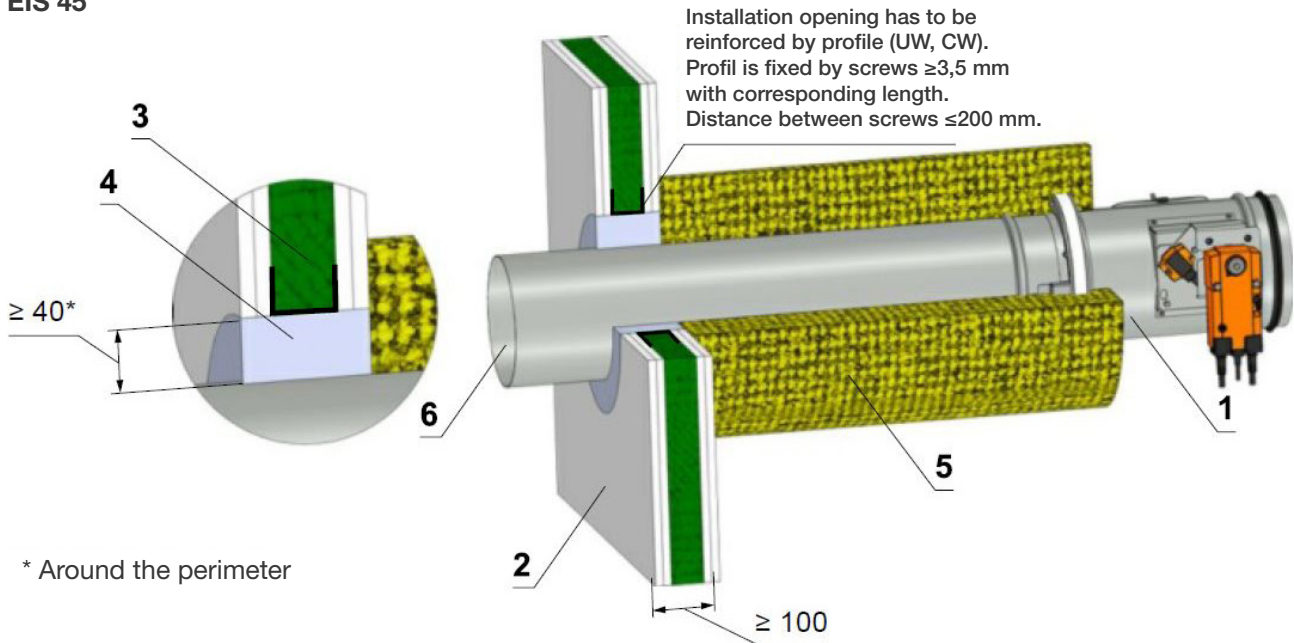

Position:

- 2 Gypsum plate
- 3 Mineral wool (type depending on the type of construction)
- 4 Mortar or gypsum
- 5 Stone wool with wired mat on one side, density 66 kg/m³
- 6 Duct

Used materials - example:**

- 5 Isover Ultimate Protect Wired MAT 4.0, th. 100 mm ALU1

** The materials for stuffing box, fire protection mastic, lining and insulation materials can be replaced by another approved fire sealing system with equivalent properties. The maximum distance of the fire damper from the structure is not limited and according to EN 15882-2, the required number of suspensions acc. to EN 1366-1:2014 must be used.

The duct at the point of penetration can be anchored to the fire wall construction!

Shown schemes of incorporation and damper are illustrative only!

Fig. 30 Outside gypsum wall construction- mineral wool- stuffing box and fire protection mastic

EIS 90

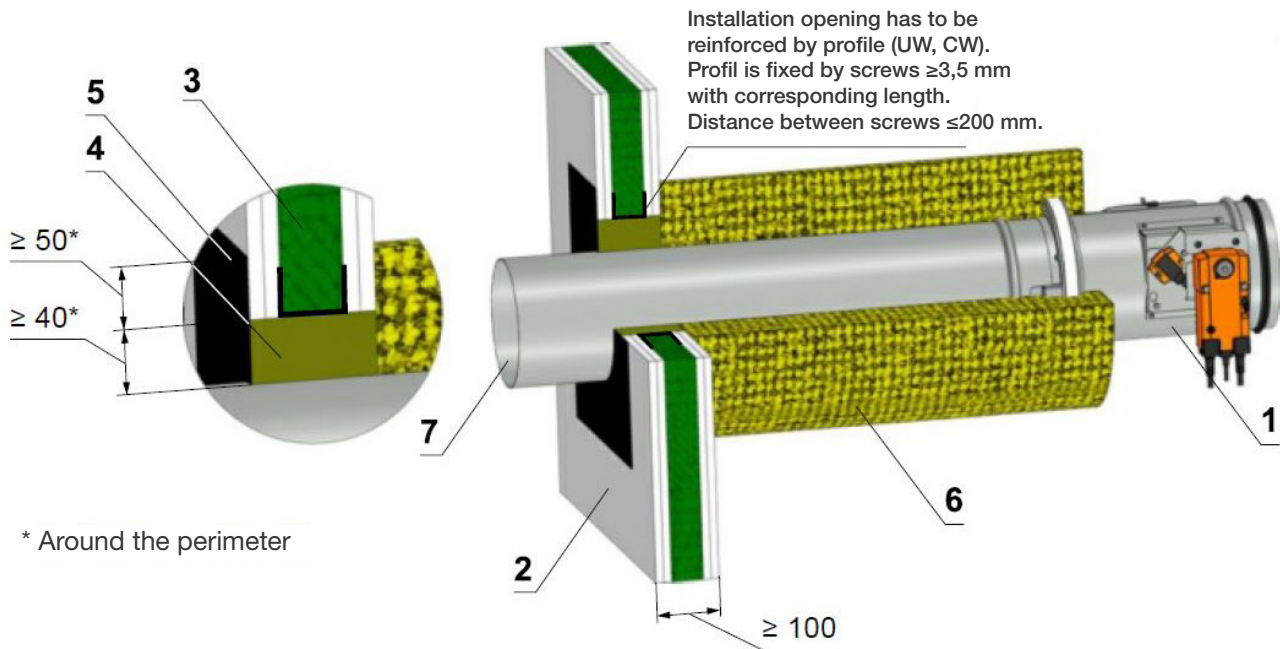

Position:

- 1 Fire damper
- 2 Gypsum plate
- 3 Mineral wool (type depending on the type of construction)
- 4 Mineral stone wool min. density 150 kg/m^3
- 5 Fire protection mastic min. thickness 1 mm
- 6 Stone wool with wired mat on one side, density 66 kg/m^3
- 7 Duct

Used materials - example:**

- 4 Promapyr, Rockwool Steprock HD, Hilti CFS-CT B 1S 140/50
- 5 Promastop - P, K, Hilti CFS-CT
- 6 Isover Ultimate Protect Wired MAT 4.0, th. 100 mm ALU1

** The materials for stuffing box, fire protection mastic, lining and insulation materials can be replaced by another approved fire sealing system with equivalent properties. The maximum distance of the fire damper from the structure is not limited and according to EN 15882-2, the required number of suspensions acc. to EN 1366-1:2014 must be used.

The duct at the point of penetration can be anchored to the fire wall construction!
Shown schemes of incorporation and damper are illustrative only!

Fig. 31 Outside gypsum wall construction- mineral wool- stuffing box and fire protection mastic and cement lime plate

EIS90 Installation opening has to be reinforced by profile (UW, CW). Profil is fixed by screws $\geq 3,5$ mm with corresponding length. Distance between screws ≤ 200 mm.

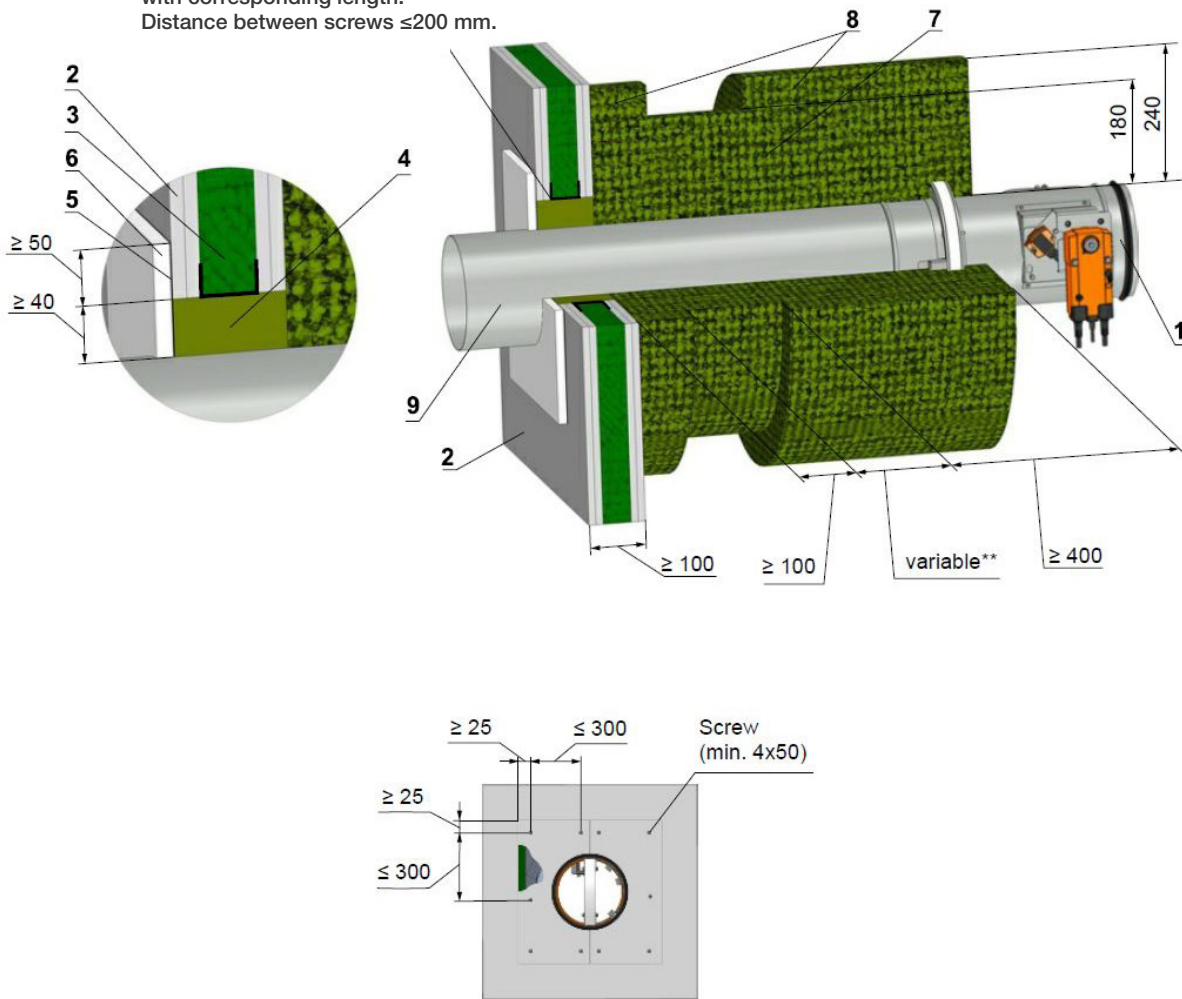

**Screws has to be fixed in wall/ceiling construction.
(If it is needed use steel bracket).**

Position:

- 1 Fire damper
- 2 Gypsum plate
- 3 Mineral wool
(type depending on the type of construction)
- 4 Stuffing box
(mineral stone wool min. density 140 kg/m^3)
- 5 Fire protection mastic min. thickness 1 mm
- 6 Cement lime plate min. thickness 15 mm
(min. density 870 kg/m^3)
- 7 Stone wool with one side stitched wire fencing
(min. density 105 kg/m^3 , thickness 180 mm (e.g. 3x60 mm))
- 8 Stone wool with one side stitched wire fencing
(min. density 105 kg/m^3 , thickness 60 mm)
- 9 Duct

Used materials - example:*

- 3 Promapyr, Rockwool Steprock HD, Hilti CFS-CT B 1S 140/50
- 4 Promapyr. Rockwool Steprock HD. Hilti CFS-CT C 1S 140/50
- 5 Promastop - P, K, Hilti CFS-CT
- 6 Promatect - H
- 7 Rockwool Wired Mat 105 th. 3x60 mm
- 8 Rockwool Wired Mat 105 th. 60 mm

* Stuffing box, fire protection mastic, cement lime plate and insulation materials can be replaced by another approved fire sealing system for damper installation with equivalent material properties.

** Depends on the distance of the flap from the construction, when the maximum distance from the construct is not limited and according to EN 15882-2 must use the required number of hinges according to EN 13366-1:2014.

**The duct at the point of penetration can be anchored to the fire wall construction!
Shown schemes of incorporation and damper are illustrative only!**

5.6 Installation in solid ceiling construction

Fig. 32 Solid ceiling construction- mortar or gypsum

EIS 120

EIS 90

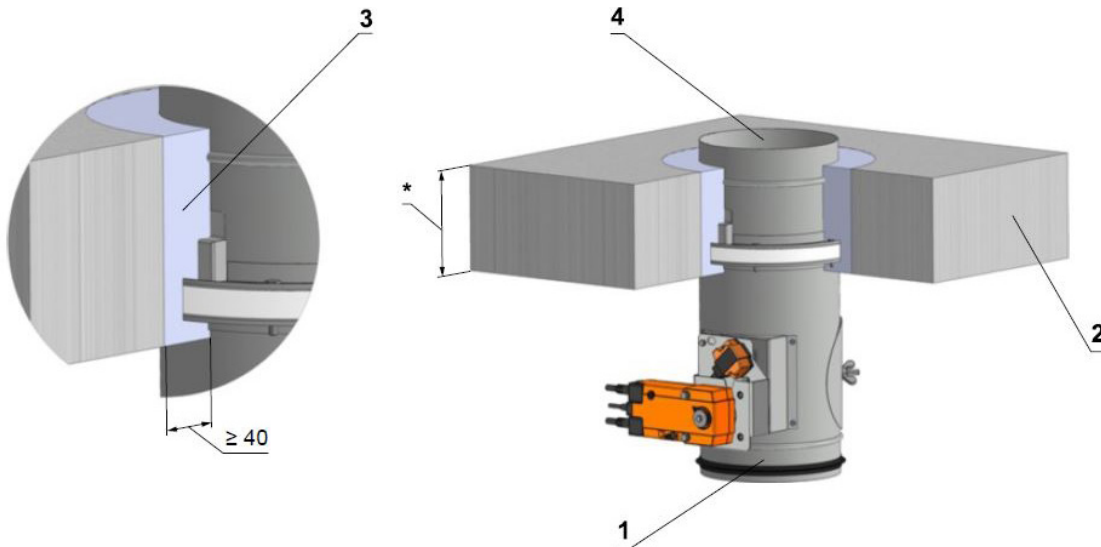

* min. 110 - Concrete/ min. 125 - Aerated concrete

Position:

- 1 Fire damper
- 2 Solid ceiling construction
- 3 Mortar or gypsum
- 4 Duct

Shown schemes of incorporation and damper are illustrative only!

Fig. 33 Solid ceiling construction- Battery- mortar or gypsum

EIS 90

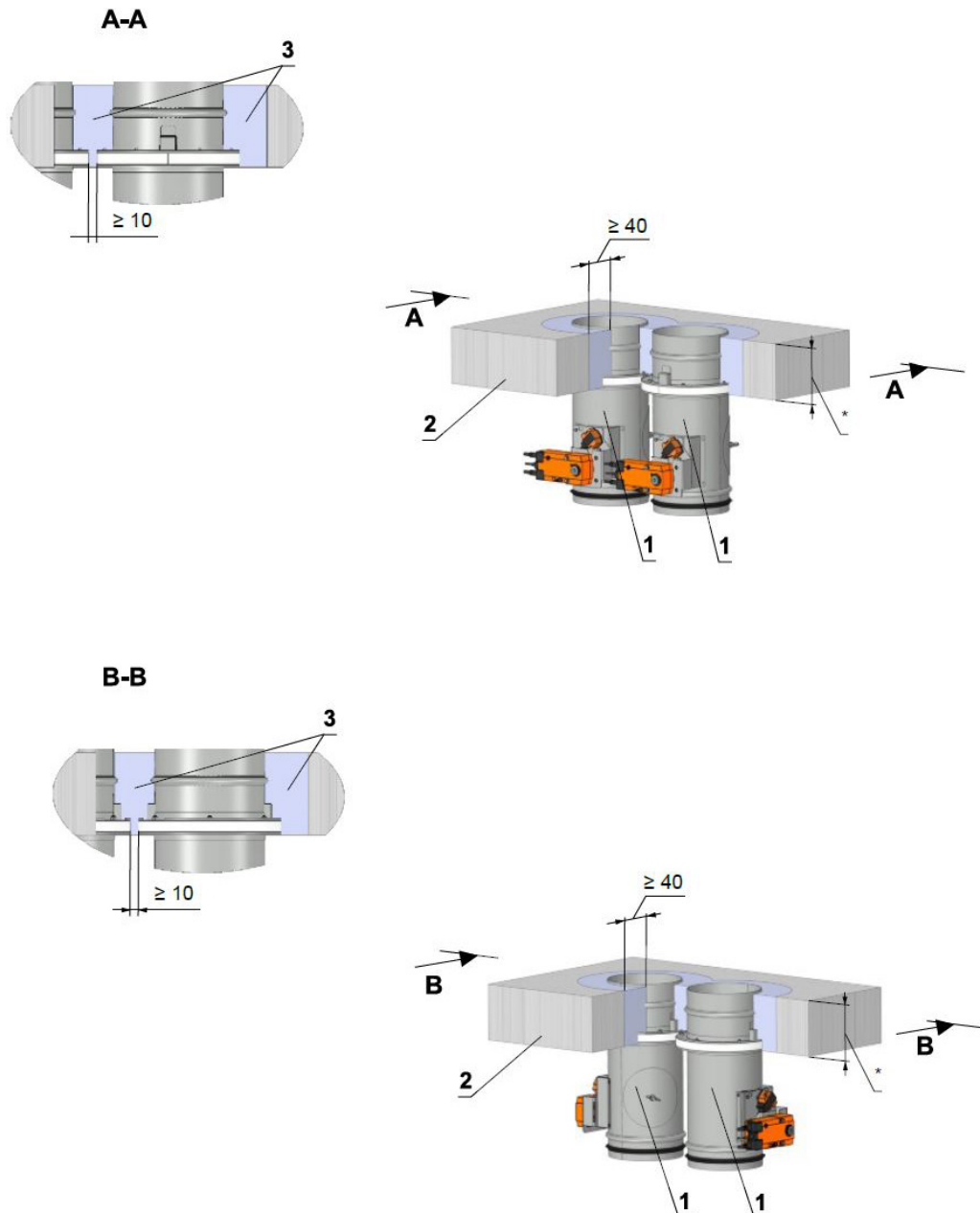

* min. 110 - Concrete/ min. 125 - Aerated concrete

Position:

- 1 Fire damper
- 2 Solid ceiling construction
- 3 Mortar or gypsum

Notice:

- Installation opening for each damper has minimal dimensions D+80 mm (D+160 mm for dampers with flanges)
- Gap between damper and construction is filled by mortar or gypsum
- Distance between dampers 70 mm
- Flange to flange connection - Up to four dampers can be installed
-

Shown schemes of incorporation and damper are illustrative only!

Fig. 34 Solid ceiling construction- stuffing box, fire protection mastic and cement lime plate

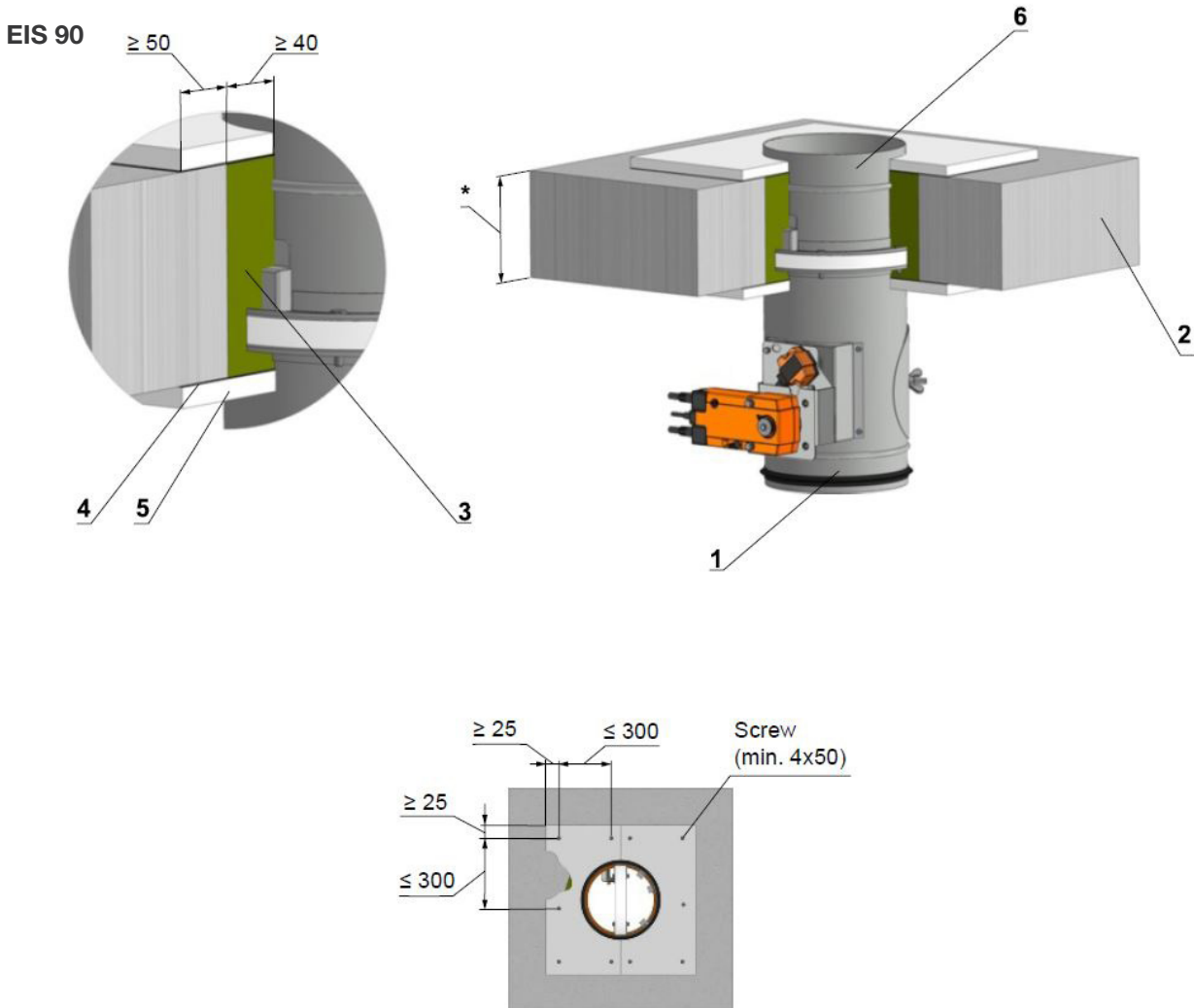

**Screws has to be fixed in wall/ceiling construction.
(If it is needed use steel bracket).**

* min. 110 - Concrete/ min. 125 - Aerated concrete

Position:

- 1 Fire damper
- 2 Solid ceiling construction
- 3 Stuffing box (mineral stone wool min. density 140 kg/m³)
- 4 Fire protection mastic min. thickness 1 mm
- 5 Cement lime plate min. thickness 15 mm min. density 870 kg/m³
- 6 Duct

Used materials - example:*

- 3 Promapyr, Rockwool Steprock HD, Hilti CFS-CT B 1S 140/50
- 4 Promastop - P, K, Hilti CFS-CT
- 5 Promatect - H

**** Fire resistant insulation and fire resistant board can be replaced by another approved fire sealing system for damper installation with equivalent material properties.**

**The damper must be anchored to the fire ceiling construction!
Shown schemes of incorporation and damper are illustrative only!**

Fig. 35 Solid ceiling construction- Weichschott

EIS 90

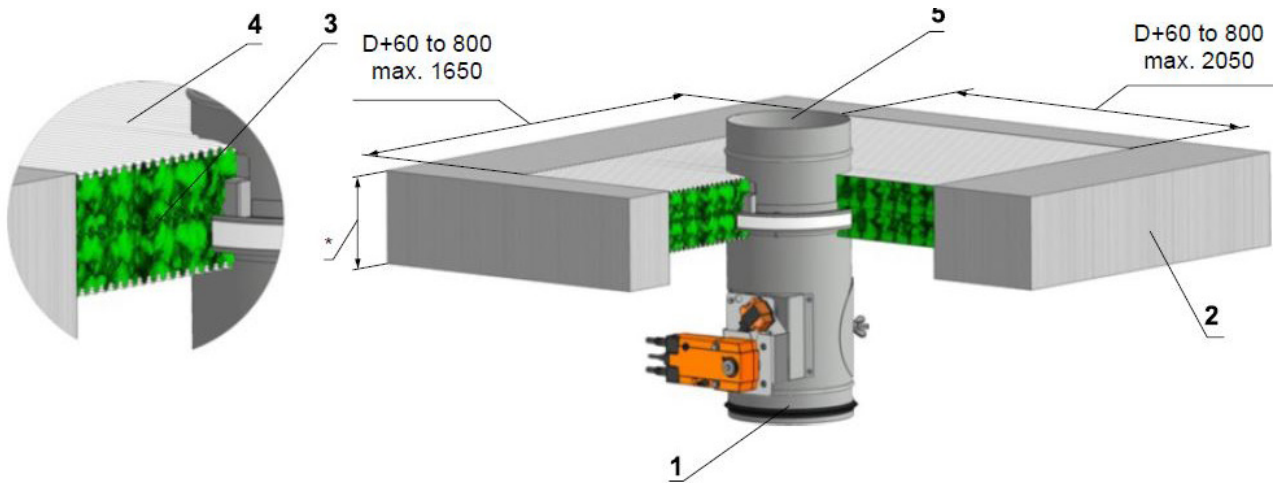

* min. 110 - Concrete/ min. 125 - Aerated concrete

Position:

- 1 Fire damper
- 2 Solid ceiling construction
- 3 Fire resistant board
- 4 Fire stop coating thickness 1 mm
- 5 Duct

Used materials - example:*

- 3 Hilti CFS-CT B 1S 140/50
- 4 Hilti CFS-CT

**** Fire resistant insulation and fire resistant board can be replaced by another approved fire sealing system for damper installation with equivalent material properties.**

Shown schemes of incorporation and damper are illustrative only!

5.7 Installation outside solid ceiling construction

Fig. 36 Outside solid ceiling construction- mineral wool- mortar or gypsum

EIS 90

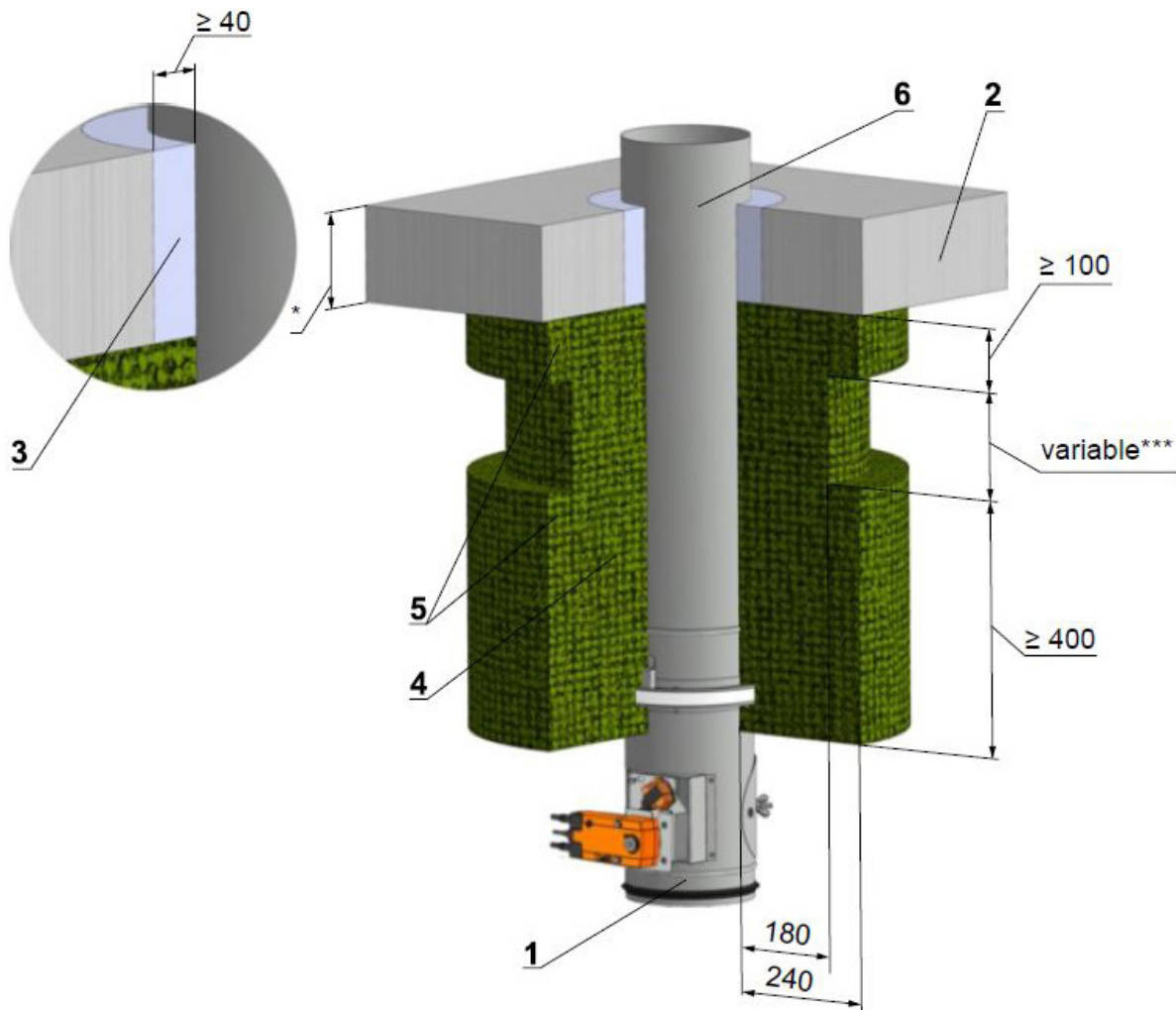

* min. 110 - Concrete/ min. 125 - Aerated concrete

Position:

- 1 Fire damper
- 2 Solid ceiling construction
- 3 Mortar or gypsum
- 4 Stone wool with one side stitched wire fencing (min. density 105 kg/m³), thickness 180 mm (e.g. 3x60 mm)
- 5 Stone wool with one side stitched wire fencing (min. density 105 kg/m³), thickness 60 mm
- 6 Duct

** Stuffing box, fire protection mastic, cement lime plate and insulation materials can be replaced by another approved fire sealing system for damper installation with equivalent material properties.

*** Depends on the distance of the flap from the construction, when the maximum distance from the construct is not limited and according to EN 15882-2 must use the required number of hinges according to EN 13366-1:2014.

**The duct at the point of penetration can be anchored to the fire ceiling construction!
Shown schemes of incorporation and damper are illustrative only!**

Fig. 37 Outside solid ceiling construction- concrete

EIS 90

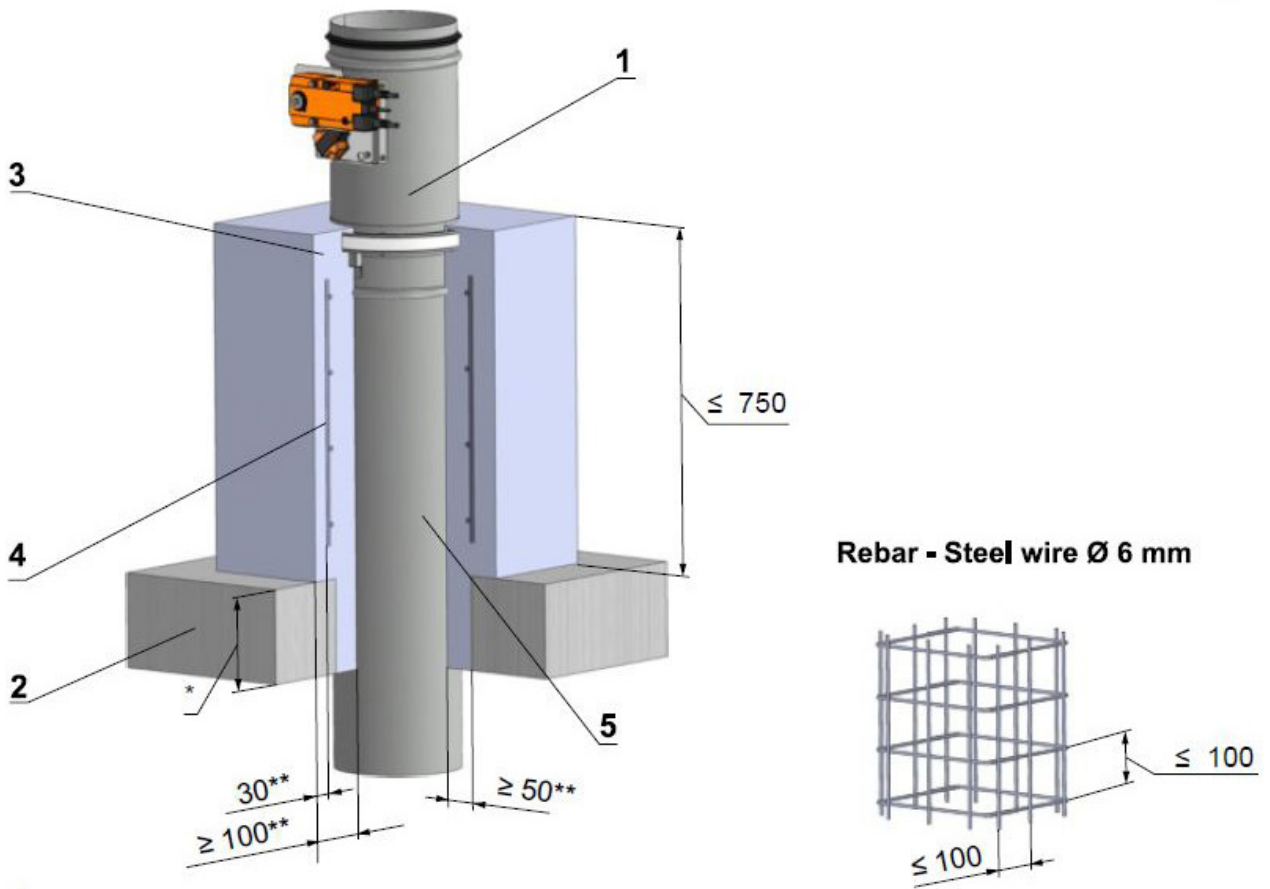

* min. 110 - Concrete/ min. 125 - Aerated concrete

** Around the perimeter

Position:

- 1 Fire damper
- 2 Solid ceiling construction
- 3 Concrete B20
- 4 Rebar
- 5 Duct

Shown schemes of incorporation and damper are illustrative only!

6. Suspension system

6.1 Mounting to the ceiling wall

Fig. 38 Mounting to the ceiling wall

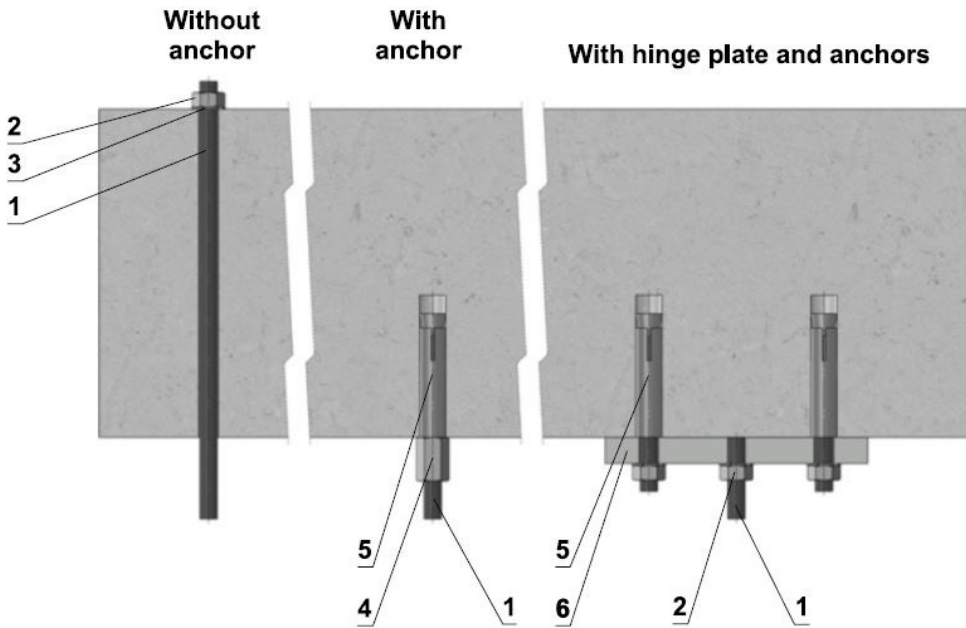

Hinge plates

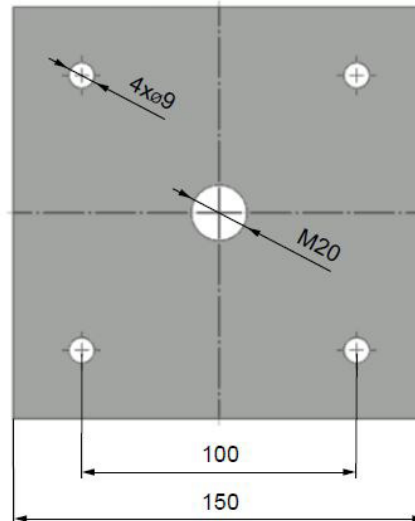
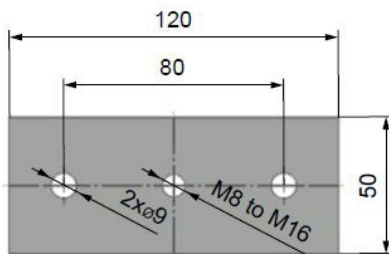

Load capacities of threaded hanger rods F [N] at the required resistance 90 minutes

Position:

- 1 Threaded rod M8 – M20
- 2 Nut
- 3 Washer
- 4 Coupling Nut
- 5 Anchor
- 6 Hinge plate - min. thickness 10 mm

Size	As [mm ²]	Weigh G [kg]	
		for 1 piece	for 1 pair
M8	366	22	44
M10	58	35	70
M12	84,3	52	104
M14	115	70	140
M16	157	96	192
M18	192	117	234
M20	245	150	300

6.2 Horizontal installation

Fire dampers can be suspended by using threaded rods and a mounting profiles. Load the suspension system depend on weight of the fire damper.

Damper assembly procedures must be done so as all load transfer from the fire separating constructions to the damper body is absolutely excluded. Back-to-back air-conditioning piping must be hung or supported so as all load transfer from the back-to-back piping to the damper is absolutely excluded.

Threaded rods longer than 1,5 m require fire-resistant insulation.

Threaded rod fixing to the ceiling construction - see fig. 32

Fig. 39 Suspension- horizontal duct

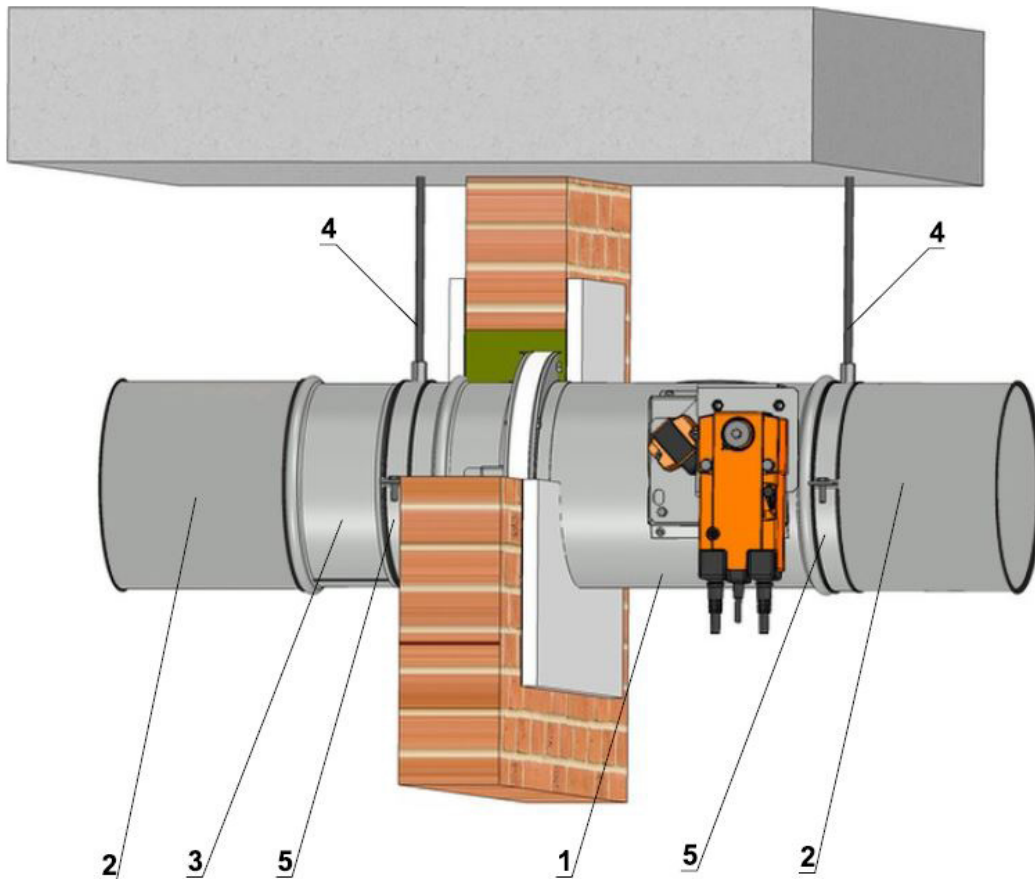

Position:

- 1 Fire damper
- 2 Damping pad
- 3 Extension piece
- 4 Threaded rod
- 5 Suspension ring

Examples of using materials - **HILTI, SIKLA, MÜPRO** etc.

Shown schemes of incorporation and damper are illustrative only!

6.3 Vertical installation

Fire dampers can be suspended by using threaded rods and a mounting profiles. Load the suspension system depend on weight of the fire damper.

Damper can be suspended from the ceiling construction or supported above the ceiling construction.

Damper assembly procedures must be done so as all load transfer from the fire separating constructions to the damper body is absolutely excluded. Back-to-back air-conditioning piping must be hung or supported so as all load transfer from the back-to-back piping to the damper is absolutely excluded.

Threaded rods longer than 1,5 m require fire-resistant insulation.

Fig. 40 Suspension- vertical duct

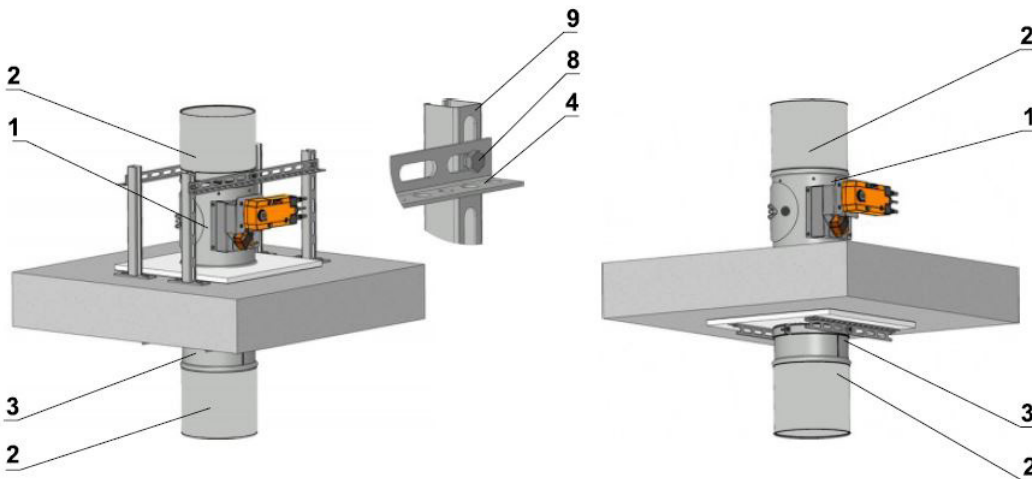

Actuating mechanism is placed under the ceiling construction

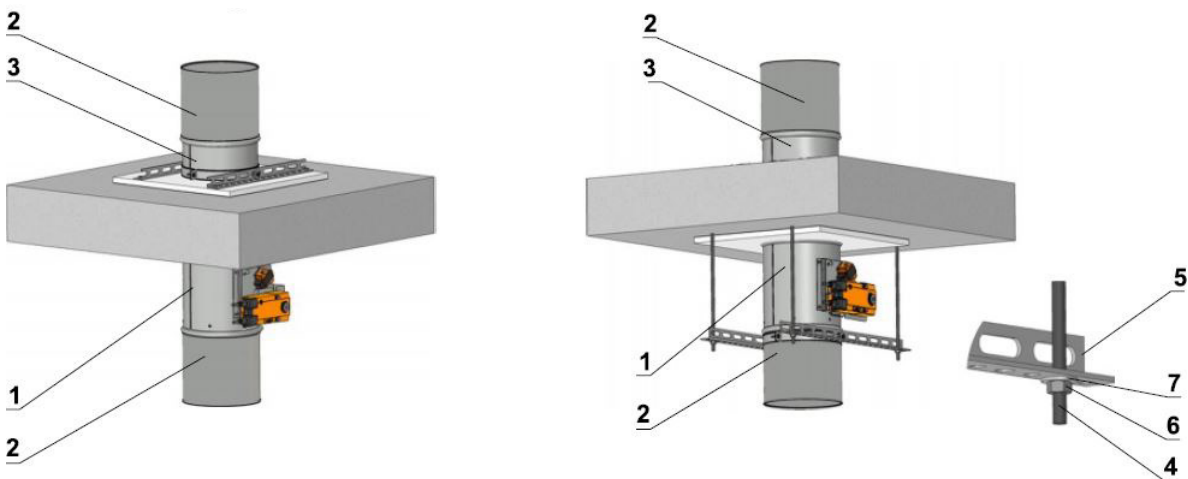

Notice: Damper must be firmly connected with extension piece by screws or rivets.

Position:

- 1 Fire damper
- 2 Damping pad
- 3 Extension piece
- 4 Threaded rod
- 5 Mounting rail
- 6 Nut
- 7 Washer
- 8 Screw connection
- 9 Mounting profile
- 10 Bolt
- 11 Screw or rivet

Examples of using materials - **HILTI, SIKLA, MÜPRO** etc.

Shown schemes of incorporation and damper are illustrative only!

6.4 Round fire damper suspension on the wall- horizontal installation

Duct between fire damper and fire separating construction can be suspended by using threaded rods and suspension rings. Load the suspension system depend on weight of the fire damper and duct system.

Max. length between two suspension systems is 1500 mm.

Damper assembly procedures must be done so as all load transfer from the fire separating constructions to the damper body is absolutely excluded. Back-to-back air-conditioning piping must be hung or supported so as all load transfer from the back-to-back piping to the damper is absolutely excluded.

Threaded rod fixing to the ceiling construction.

The insulation boards are fastened to the duct by weld pins. Distance between weld pins, distance between weld pins and flanges is dependent on the materials. For more information see documentation of insulation manufacturer.

Fig. 41 Examples of suspension of dampers on the wall- horizontal installation

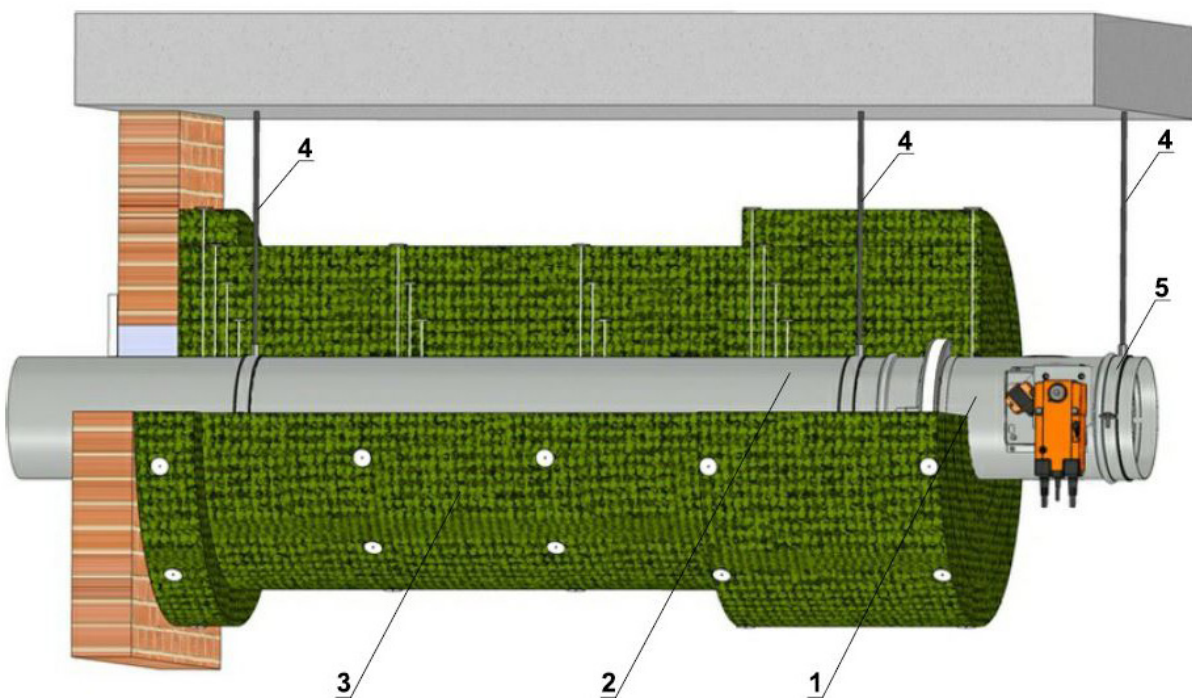

Insulation layers on the duct.

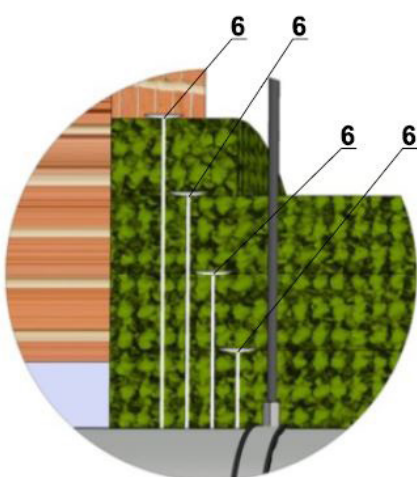

Position:

- 1 Fire damper
- 2 Duct
- 3 Insulation
- 4 Threaded rod
- 5 Suspension ring
- 6 Weld pin

Suspension system

Shown schemes of incorporation and damper are illustrative only!

III. Technical data

7. Pressure loss

7.1 Pressure loss calculation

$$\Delta p = \xi \cdot \rho \cdot \frac{w^2}{2}$$

Δp	[Pa]	pressure lost
w	[m.s ⁻¹]	air flow speed in nominal damper section
ρ	[kg.m ⁻³]	air density
ξ	[-]	coefficient of local pressure loss for the nominal damper section (see Tab. 11.1.1.)

7.2 Determination of pressure loss by using diagram $\rho = 1,2 \text{ kg} \cdot \text{m}^{-3}$

Diagram 7.2.1. Pressure losses for air density $\rho = 1,2 \text{ kg} \cdot \text{m}^{-3}$

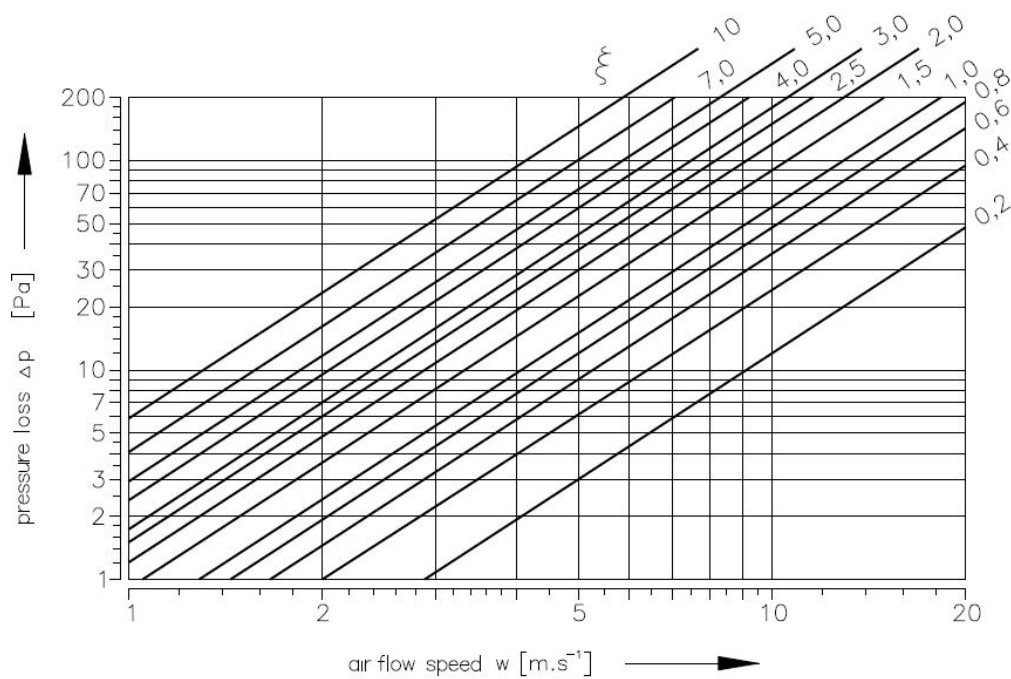

8. Coefficient of local pressure loss ξ (-)

8.1 Coefficient of local pressure loss ξ (-)

Tab 8.1.1. Coefficient of local pressure loss

D	900	1000
ξ	0,090	0,083

9. Noise data

9.1 Level of acoustic output corrected with filter A.

$$L_{WA} = L_{W1} + 10 \log(S) + K_A$$

- L_{WA} [dB(A)] level of acoustic output corrected with filter A
- L_{W1} [dB] level of acoustic output L_{WA} related to the 1 m² section (see Tab. 9.3.1.)
- S [m²] duct cross section
- K_A [dB] correction to the weight filter A (viz Tab. 9.3.2.)

9.2 Level of acoustic output corrected with filter A.

$$L_{Woct} = L_{W1} + 10 \log(S) + L_{rel}$$

- L_{Woct} [dB] level of acoustic output corrected with filter A
- L_{W1} [dB] level of acoustic output L_{WA} related to the 1 m² section (see Tab. 12.3.1.)
- S [m²] duct cross section
- L_{rel} [dB] correction to the weight filter A (viz Tab. 12.3.2.)

9.3 Table of acoustic values

Tab 9.3.1. Level of accoustic output L_{W1} [dB] related to the 1 m² section

w [m.s ⁻¹]	ξ [-]											
	0,1	0,2	0,3	0,4	0,6	0,8	1	1,5	2	2,5	3	3,5
2	9	11,5	14,7	16,9	20,1	22,3	24,1	27,2	29,4	31,2	32,6	33,8
3	16,7	22,1	25,3	27,5	30,7	32,9	34,6	37,8	40	41,7	43,2	44,4
4	24,2	29,6	32,8	35	38,1	40,4	42,1	45,3	47,5	49,2	50,7	51,9
5	30,0	35,4	38,6	40,8	44	46,2	47,9	51,1	53,3	55,1	56,5	57,7
6	34,8	40,2	43,3	45,6	48,7	51	52,7	55,8	58,1	59,8	61,2	62,4
7	38,8	44,2	47,3	49,6	52,7	55	56,7	59,9	62,1	63,8	65,2	66,4
8	42,3	47,7	50,8	53,1	56,2	58,4	60,2	63,3	65,6	67,3	68,7	69,9
9	45,4	50,7	53,9	56,1	59,3	61,5	63,3	66,4	68,6	70,4	71,8	73
10	48,1	53,5	56,6	58,9	62	64,3	66	69,1	71,4	73,1	74,5	75,7
11	50,6	56	59,1	61,4	64,5	66,7	68,5	71,6	73,9	75,6	77	78,2
12	52,8	58,2	61,4	63,6	66,8	69	70,7	73,9	76,1	77,9	79,3	80,5

Tab 9.3.2. Correction to the weight filter A

w [m/s]	2	3	4	5	6	7	8	9	10	11	12
K _A [dB]	-15,0	-11,8	-9,8	-8,4	-7,3	-6,4	-5,7	-5,0	-4,5	-4,0	-3,6

Diagram 9.3.3. Relative level expressing the shape of the spectrum L_{rel}

w [m/s]	h [Hz]							
	63	125	250	500	1000	2000	4000	8000
2	-4,5	-6,9	-10,9	-16,7	-24,1	-33,2	-43,9	-56,4
3	-3,9	-5,3	-8,4	-13,1	-19,5	-27,6	-37,4	-48,9
4	-3,9	-4,5	-6,9	-10,9	-16,7	-24,1	-33,2	-43,9
5	-4,0	-4,1	-5,9	-9,4	-14,6	-21,5	-30	-40,3
6	-4,2	-3,9	-5,3	-8,4	-13,1	-19,5	-27,6	-37,4
7	-4,5	-3,9	-4,9	-7,5	-11,9	-17,9	-25,7	-35,1
8	-4,9	-3,9	-4,5	-6,9	-10,9	-16,7	-24,1	-33,2
9	-5,2	-3,9	-4,3	-6,4	-10,1	-15,6	-22,7	-31,5
10	-5,5	-4	-4,1	-5,9	-9,4	-14,6	-21,5	-30
11	-5,9	-4,1	-4	-5,6	-8,9	-13,8	-20,4	-28,8
12	-6,2	-4,3	-3,9	-5,3	-8,4	-13,1	-19,5	-27,6

IX. Material, finishing

10. Material

10.1 Damper bodies are supplied in the design made of galvanized plate without any other surface finishing. Damper blades are made of fire resistant asbestos free boards made of mineral fibres. Control devices of dampers has cover from mechanically resistant and standing plastic and rest of the parts is galvanised without further surface treatment. Springs are galvanized. Thermal protective fuses are made of sheet brass, thickness = 0.5 mm. Fasteners is galvanized. Fasteners is galvanized.

10.2 According to the customer's requirements, damper can be made of stainless material. Specifications for stainless-steel models – classification of stainless steel:

- Class A2 – Food-grade stainless steel (AISI 304 – ČSN 17240)
- Class A4 – Chemistry-grade stainless steel (AISI 316, 316L – ČSN 17346, 17349)

The respective stainless steel is the material for all components present or accessing the damper interior; components outside the damper body are typically from galvanised sheet metal (fasteners for mounting the servo drive or mechanics, mechanics components except Item 4), frame components.

The following components, including the fasteners, are made from stainless steel at all times:

- 1) Damper body and all components permanently attached
- 2) Leaf holders, including pins, metal parts of leaf
- 3) Control components inside the damper (leaf angle selector, pin with lever)
- 4) Mechanical components entering the interior of damper body (lower sheet of mechanics, lock holder “1”, lock lever “2”, lock spring, 8 dia. stopper pin, mechanics pin)
- 5) Inspection hole cover including the clip and fasteners (if they are parts of the cover)
- 6) Bearing for torque transfer from the lever with pin on the angle selector at the leaf (made from AISI 440C)

The leaf of the damper is made from a single piece of homogeneous material Promatect-MST, thickness 40 mm.

Plastic, rubber and silicon components, sealants, foaming bands, glass-ceramic seals, housings, brass bearings of the leaf, servo drives, and end switches are identical for all material variants of the dampers.

The thermal link is identical for all material variants of the dampers. Upon specification by customer, the thermal link may be made from A4 stainless steel. The solder is standard, corresponding to the initialisation temperature.

The temperature-dependent initiator of the servo drive (sensor) is modified for stainless-steel variants of the dampers; the standard galvanised screws are replaced with stainless-steel M4 screws of corresponding class the counterpart has stainless-steel riveting M4 nuts.

Some fasteners and components are available in one class of stainless steel; the type will be used in all stainless-steel variants.

The leaf in the variants for chemical environments (Class A4) is always treated with a coating of chemically resistant Promat SR.

Any other requirements for the design shall be considered atypical and shall be addressed on an individual basis.

IX. Inspection, testing

11. Inspection, testing

- 11.1 The appliance is constructed and preset by the manufacturer, its operation is dependent on proper installation and adjustment.

IX. Transportation and storage, warranty

12. Logistics terms

- 12.1 Dampers are transported by box freight vehicles without direct weather impact, there must not occur any sharp shocks and ambient temperature must not exceed +40°C. Dampers must be protected against mechanic damages when transported and manipulated. During transportation, the damper blade must be in the "CLOSED" position.
- 12.2 Dampers are stored indoor in environment without any aggressive vapours, gases or dust. Indoor temperature must be in the range from -30°C to +40°C and maximum relative humidity 95 % (avoid condensation on the damper body). Dampers must be protected against mechanic damages when transported and manipulated.

IX. Assembly, attendance, maintenance and revisions

13. Assembly

- 13.1 All effective safety standards and directives must be observed during fire damper assembly.
- 13.2 The damper body should not be deformed in the course of bricking in. Once the damper is built in, its blade should not grind on the damper body during opening or closing.

Fig. 42 Embedding/ fixing the damper

**Protecting the damper against buckling,
above all when there are big diameters and sizes of fire dampers!**

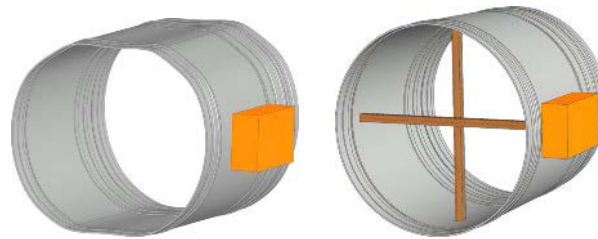

WRONG!

Brace with wooden blocks

- 13.3 To ensure reliable fire damper function it is necessary to avoid blocking the closing mechanism and contact surfaces with collected dust, fibre and sticky materials and solvents.

14. Entry into service and revisions

- 14.1 Before entering the dampers into operation after their assembly and by sequential checks, the following checks must be carried out. Visual inspection of proper damper integration, inside damper area, damper blade, contact surfaces and silicon sealing. Check of thermal protective fuse and closing mechanism. Check the closing function of the damper blade. This can be done by removing of thermal fuse from damper body.
Before entering the dampers with actuating mechanism into operation after their assembly and by sequential checks. Check of blade displacement into the breakdown position "CLOSED" can be done after cutting off the actuating mechanism supply (e.g. by pressing the RESET button at the thermoelectrical starting mechanism BAT or cutting off the supply from ELECTRICAL FIRE SIGNALISATION). Check of blade displacement back into the "OPEN" position can be done after restoration of power supply (e.g. by releasing the RESET button or restoration of supply from ELECTRICAL FIRE SIGNALISATION). Without power supply, the damper can be operated manually and fixed in any required position. Release of the locking mechanism can be achieved manually or automatically by applying the supply voltage. It is recommended to provide periodical checks, maintenance and service actions on Fire Equipment by Authorized persons. The authorized persons can be trained by Producer, or by authorized Distributor. All effective safety standards and directives must be observed during fire damper assembly.
For regular or exceptional inspection of interior of fire damper, micro-camera device can be used. On each fire damper is inspection hole. In the case of inspection by camera, take out the black rubber cap, insert the camera inside the damper, check interior and at the end of inspection, put the rubber cap back tightly to cover the empty hole.
- 14.2 Before entering the dampers with manual control (design .01, .11, .80) into operation after their assembly and by sequential checks and following checks must be carried out.

Verification of closing device and thermal fuse:

When you verify functionality in position "CLOSED" shall be made following:

Adjustment of damper blade in position "CLOSED" shall be made following:

- Damper is in „OPEN“ position.
- By pressing control button mechanism, you close damper in "CLOSED" position.
- Check damper blade adjustment in "CLOSED" position.
- Closing must be strong and control lever must be in "CLOSED" position.
- If closing is not sufficiently strong and damper control lever is not in "CLOSED" position, you must contact manufacturer and order new mechanism.

- Mechanism dimension is marked M1 to M4, according to internal forces of spring.

Adjustment of damper blade in position "OPEN" shall be made following:

- Rotate control lever by 90°.
- Lever get fasten automatically in "OPEN" position.
- Check damper blade adjustment in "OPEN" position.

- 14.3 Before entering the dampers with actuating mechanism into operation after their assembly and by sequential checks and following checks must be carried out.
Check of blade displacement into the breakdown position "CLOSED" can be done after cutting off the actuating mechanism supply (e.g. by pressing the RESET button at the thermoelectrical starting mechanism BAT or cutting off the supply from ELECTRICAL FIRE SIGNALISATION).
Check of blade displacement back into the "OPEN" position can be done after restoration of power supply (e.g. By releasing the RESET button or restoration of supply from ELECTRICAL FIRE SIGNALISATION).
- 14.4 Manual operation
Without power supply, the damper can be operated manually and fixed in any required position. Release of the locking mechanism can be achieved manually or automatically by applying the supply voltage.
- 14.5 It is recommended to provide periodical checks, maintenance and service actions on Fire Equipment by Authorized persons schooled by Producer.
- 14.6 All effective safety standards and directives must be observed during fire damper assembly.
- 14.7 Dampers could be displaced into position "CLOSED" only in case that ventilator, or Air Handling Unit is switched off. The goal is the securing of proper closing and safe function of Fire Damper in case of Fire.

15. Spare parts

- 15.1 Spare parts are supplied only on basis of an order.
- 15.2 Control for square damper and round damper is identical.

16. Restore function of actuating mechanism after fuses initiation

- 16.1 If fuse Tf1 is initiated (duct outside temperature) than is necessary to change thermoelectrical starting mechanism BAT72B-S. Whereas is initiation temperature higher than actuator mechanism operating temperature +50°C, recommended actuating mechanism manufacturer make complete revision or change actuating mechanism and thermoelectrical starting mechanism.
- 16.2 If fuses Tf2/Tf3 are initiated (duct inside temperature) than is possible change only part ZBAT72 or ZBAT95 (according initiating temperature).
- 16.3 Control for square damper and round damper is identical.
- 16.4 Ordering key

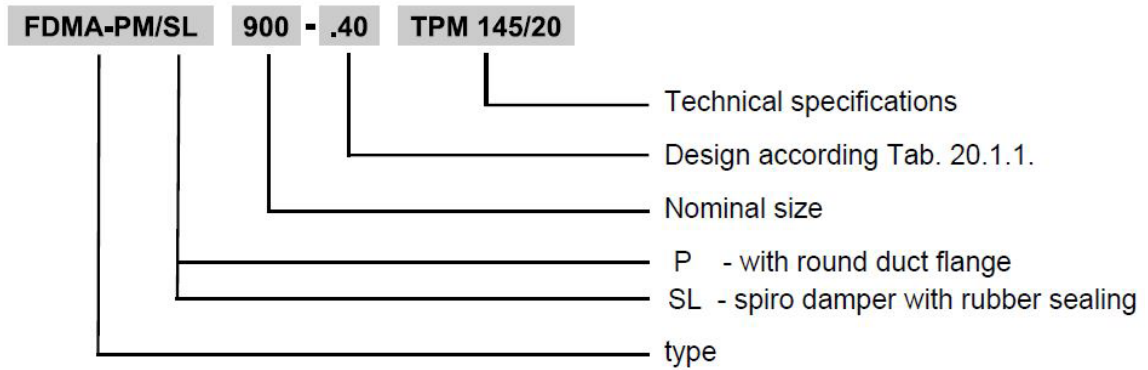

If installation holders, installation frame or design for installation in Weichschott system are requested, it has to be mentioned separately in the order. Installation frame could be fixed to the damper body or supplied separately.

Tab 16.4.1.Dampers design

Dampers design	Additional digit
Manual and thermal	.01
Manual and thermal (ZONE 1, 2)	.02
Manual and thermal with a terminal switch („CLOSED“)	.11
Manual and thermal with a terminal switch („CLOSED“) (ZONE 1, 2)	.12
With actuating mechanism BF 230-TN	.40
With actuating mechanism ExMax-15-BF (AC 230 V, AC/DC 24 V) with thermoelectrical starting mechanism (ZONE 1,2)	.42
With actuating mechanism BF 24-TN	.50
Manual and thermal with two terminal switches („OPEN“, „CLOSED“)	.80
Manual and thermal with two terminal switches („OPEN“, „CLOSED“) (ZONE 1,2)	.81

17. Data label

17.1 Data label is placed on the damper body

MANDÍK [®]		MANDÍK, a.s. Dobříšská 550, 267 24 Hostomice, Czech Republic	
FIRE DAMPER - FDMA-PM			
DIMENSION:		ACTUATING SYSTEM:	
YEAR/SER.NO.:		WEIGHT (kg):	
FIRE PROTEC. CLASS: EI 90 (ve ho i ↔ o) S			
TPM 145/20	Cert. No.: 1391-CPR-2016/0158, DoP: PM/FDMA-PM/01/20/1	EN 15650:2010	CE 1391



MANUAL



ETS NORD AS

Address: Peterburi tee 53
11415 Tallinn
Estonia

Phone: +372 680 7360
info@etsnord.ee
www.etsnord.ee

ETS NORD Finland

Address: Pakkasraitti 4
04360 Tuusula
Finland

Phone: +358 0401 842 842
info@etsnord.fi
www.etsnord.fi

ETS NORD Sweden

Address: Järsjögatan 7
69235 Kumla
Sweden

Phone: +46 70 780 50 26
info@etsnord.se
www.etsnord.se

