

KROS Regulating damper

Damper for regulating air flow in round duct systems.

- Easy to install
- Equipped with rubber gaskets
- Tightness class EN 1751, class C



Structure and dimensions

Manufactured of galvanized steel. Equipped with rubber gaskets. Polyamide bushings (max +150°C). Manually adjustable.

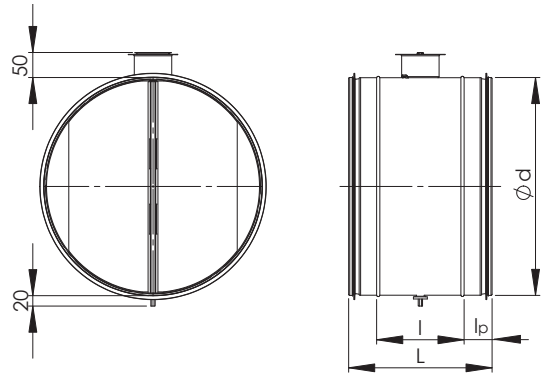

Nominal size, d mm	l, mm	l _p , mm	L, mm	Weight, kg
80	95	30	155	0,29
100	95	30	155	0,35
125	95	30	155	0,45
160	95	30	155	0,6
200	120	50	220	0,8
250	120	50	220	1,3
315	120	50	220	1,8
400	133	61	255	3,0
500	133	61	255	4,4
630	130	65	255	6,0

Technical data

KROS 100

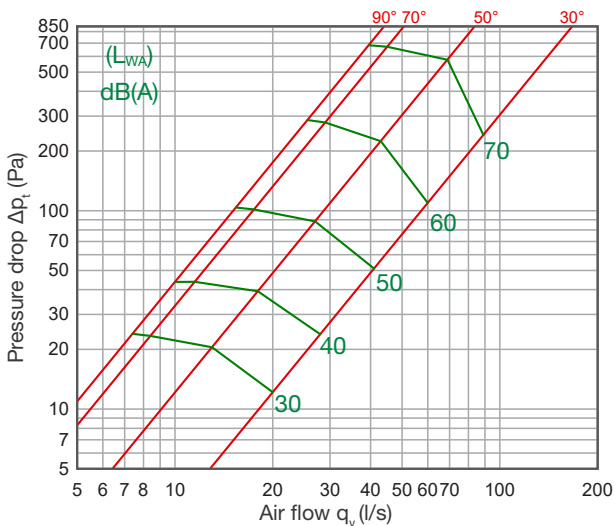

KROS 125

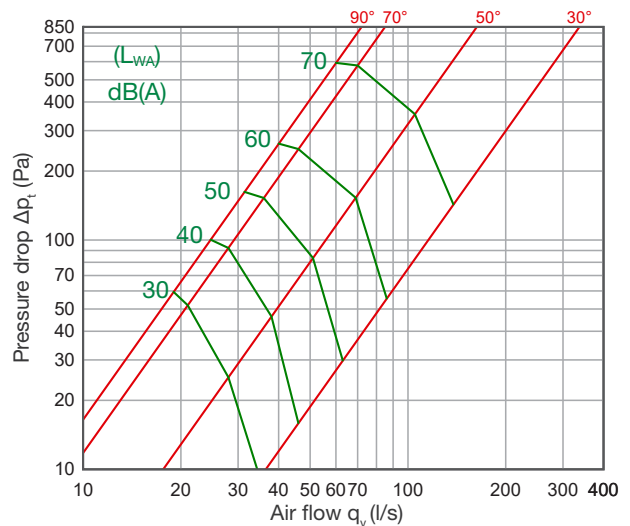

KROS 160

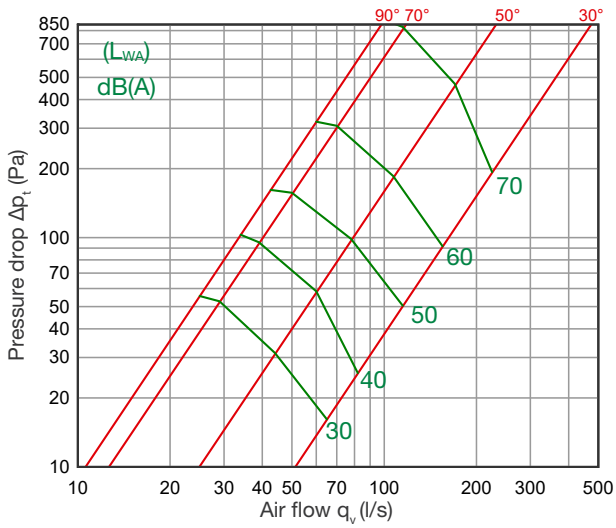

KROS 200

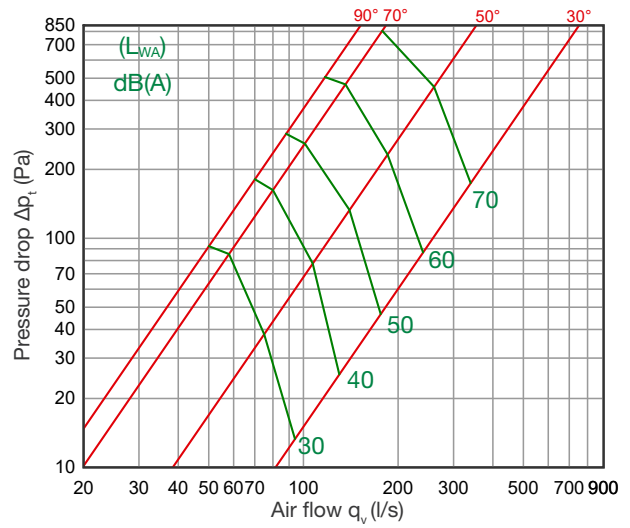

KROS 250

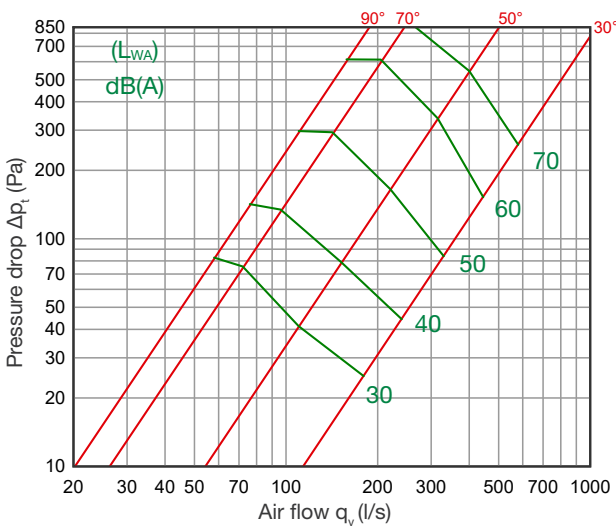

KROS 315

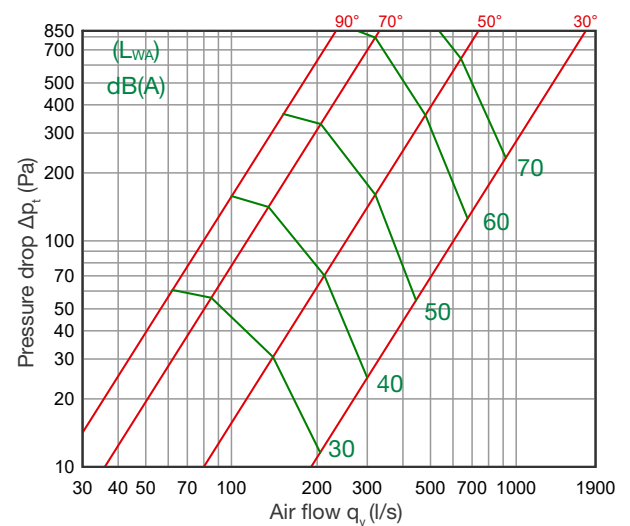

KROS 400

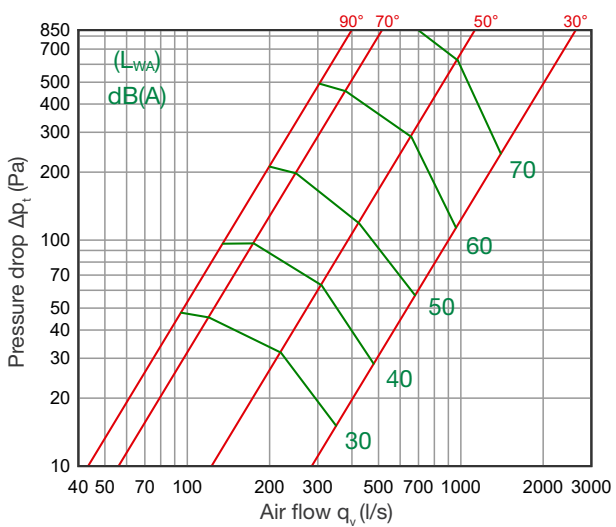

KROS 500

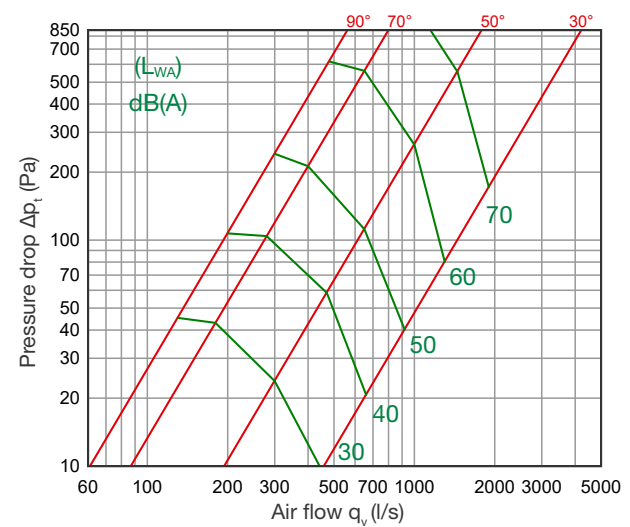

KROS 630

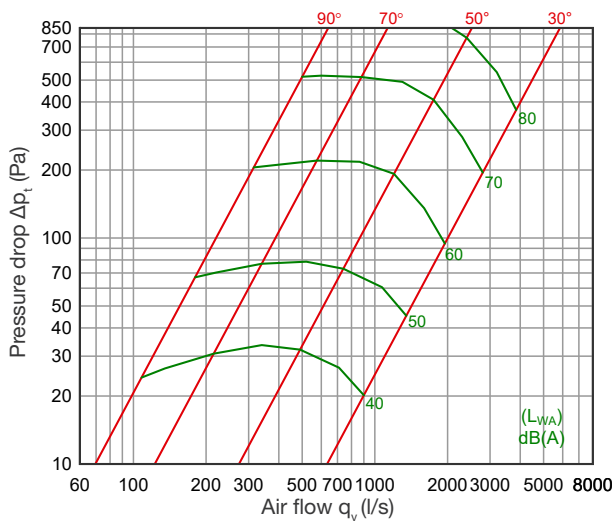

Product marking

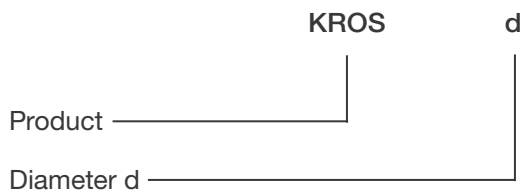

Example: KROS 315

Installation

Installation according to NORDduct installation instructions.