

Pikemad kui 3,0 m raamid valmistatakse mitmest osast ja ühendatakse omavahel jätkuplaadiga!

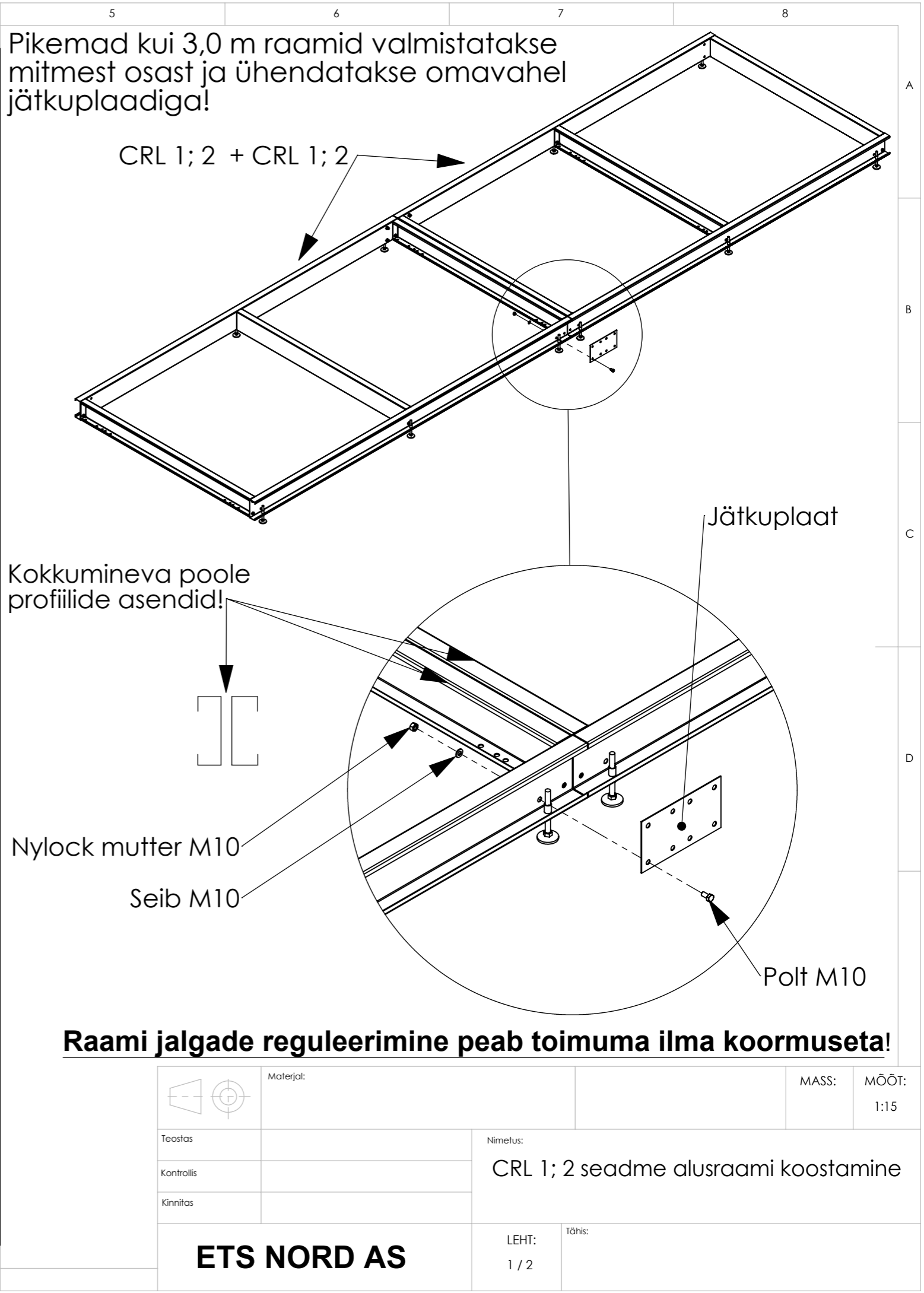

Raami jalgade reguleerimine peab toimuma ilma koormuseta!

		Materjal:	MASS:	MÕÖT:
Teostas		Nimetus:		1:15
Kontrollis		CRL 1; 2 seadme alusraami koostamine		
Kinnitas		LEHT:	Tähis:	
ETS NORD AS		1 / 2		

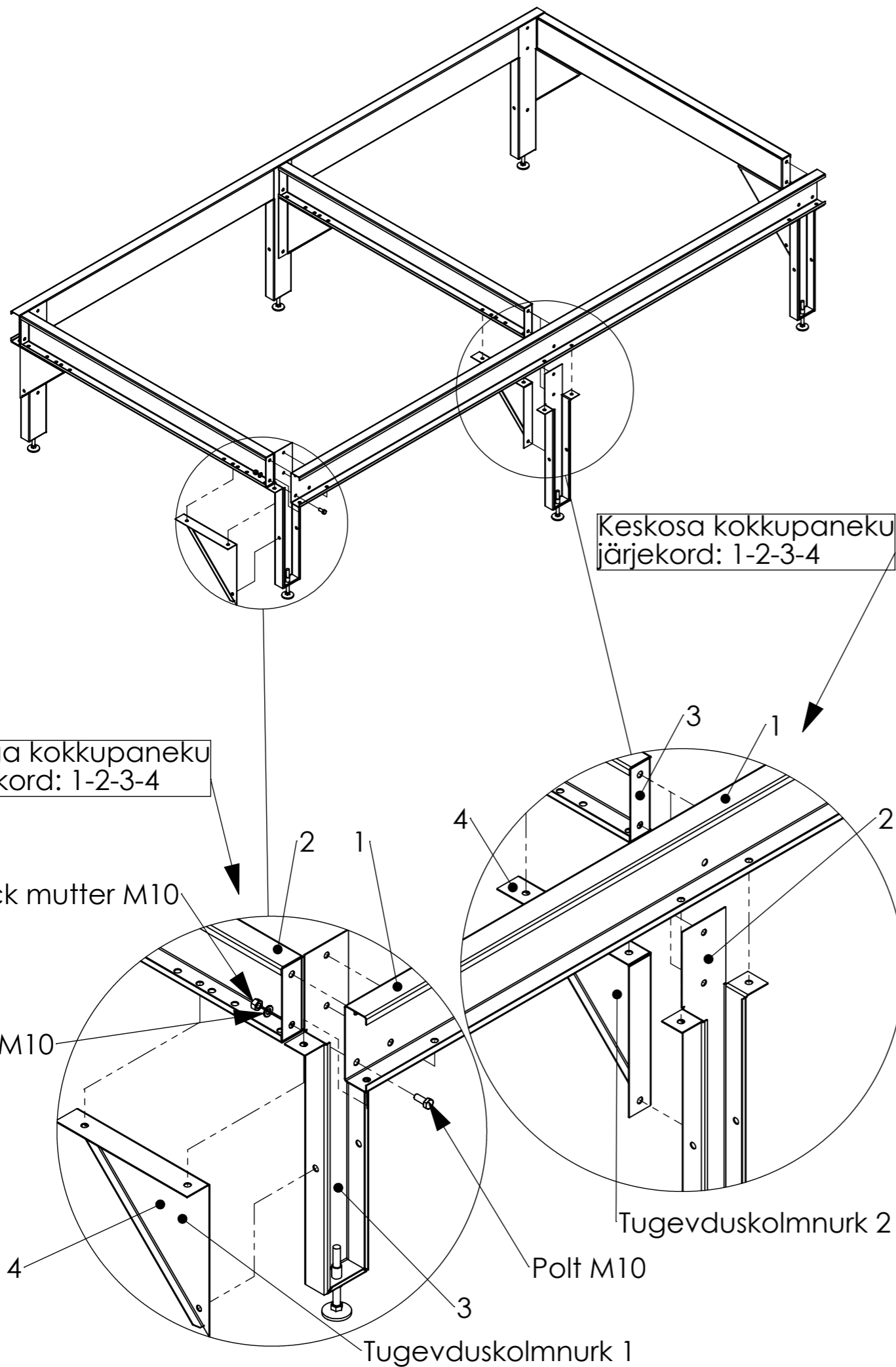

Pikemad kui 3,0 m raamid valmistatakse mitmest osast ja ühendatakse omavahel jätkuplaadiga!

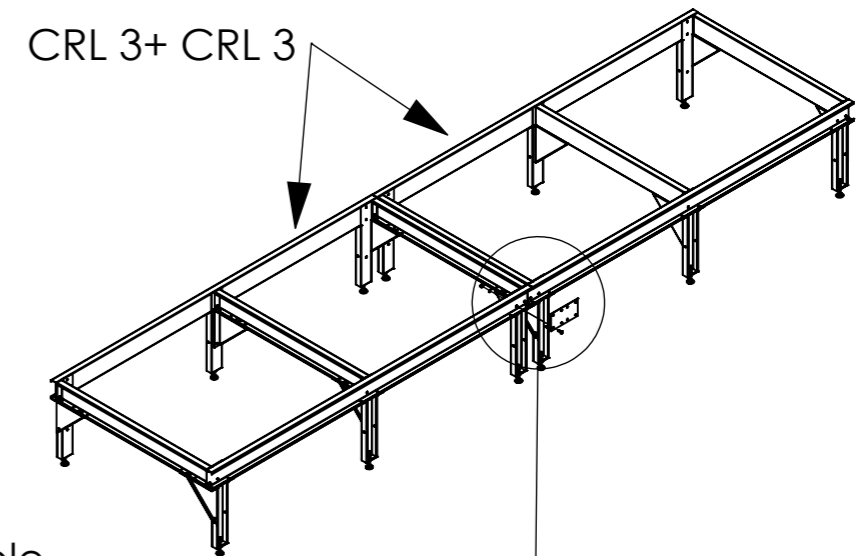

Kokkumineva poole profiilide asendid!

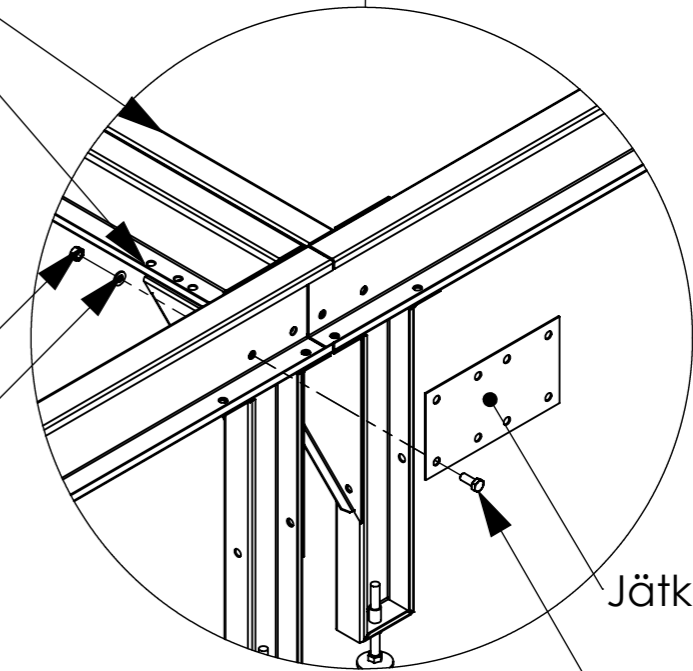
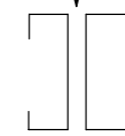

Raami jalgade reguleerimine peab toimuma ilma koormuseta!

Materjal:			
Teostas		Nimetus:	
Kontrollis		CRL 3 seadme alusraami koostamine	
Kinnitas		LEHT:	Tähis:
ETS NORD AS		2 / 2	