

NORDduct installation and maintenance instructions

NORDduct – is a type-approved group of round duct products, including components for building up ventilation systems for air intake, exhaust and natural air circulation.

NORDduct system includes spiral ducts, bends, couplings, reducers, take-offs, tees, end caps and intakes. NORDduct round ducts and parts are manufactured according to the standard EVS-EN 1506:2007. NORDduct ducts and parts meet tightness class D requirements provided that the products are assembled according to instructions.

All NORDduct standard products are equipped with EPDM rubber seals, which maintain their proper characteristics after installation and are very temperature resistant.

Ducts and parts that are made of 1.0 and 1.2 mm hot-dip galvanized sheet must be installed and compacted, where is required a certain fire resistance (eg. professional kitchens, grills, etc.), so that the duct connections are fire-resistant, and their assembly shall be such that the channel can be freely under the influence of temperature increase.

Installation

1. Preliminary operations

- Before commencing ensure that the installation location corresponds to the design drawings and check that the installation of ductwork is possible according to the drawings before delivering system components.
- Stock necessary ducts and system components in a closed area of the installation place and protect them from atmospheric impacts.
- Ensure that ducts and other components are not damaged in a way affecting their density.
- Use of damaged parts must be avoided.

2. Connection of duct components

1. Cut ducts to required sizes using a cutting disc or nibbler, taking account the fitting lengths of system components. Cuts must be rectangular to the duct axis. Wear protective glasses while cutting. Always clean off metal particles after cutting. Round off cut edges, i.e. by file to avoid possible seal damages.
2. Preliminary attach fittings to ducts on the floor. Turn and push components simultaneously to facilitate attaching.

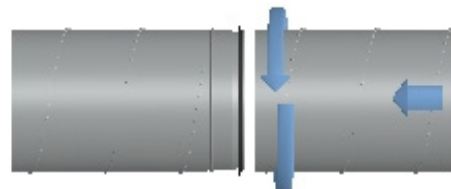

3. Use NI coupling for connection of two ducts.
4. Push the fitting into the duct until the shoulder (see Table 2, dimension L_p). Fasten all fittings by blind rivets. The minimum rivet quantity according to the table (see Table 1). The maximum distance (K) of rivets as seen from the air duct end according to the table (see Table 2). Metal particles resulting from filing should be removed. Distribute rivets as equally as possible to avoid damaging seals. When attaching always position the next rivet opposite the last one, and following the rivet to 90° from the last rivet. When positioning rivets, divide tolerances evenly on the whole diameter..

Table 1. Rivet quantity

Duct diameter, mm	Number of rivet, tk
80 – 250	3
315 – 500	4
630 - 1250	8
1600	12

5. For branching a saddle (NPS) is recommended, as this will enable connection without cutting apart a duct. Place the saddle on the duct and draw the saddle contour on the duct surface. Cut a hole into the duct about 10 mm smaller than the contour. Start cutting from the centre hole of the area to be cut. Apply a sealing compound on hole edges before attaching the saddle. Place the saddle in the correct position and attach (see item 4).

NORDduct installation and maintenance instructions

Table 2. Rivet position distances

Duct diameter, mm	K_{max} , mm
80 – 200	12
250 – 400	15
500 – 630	30
800	40
1000 – 1600	45

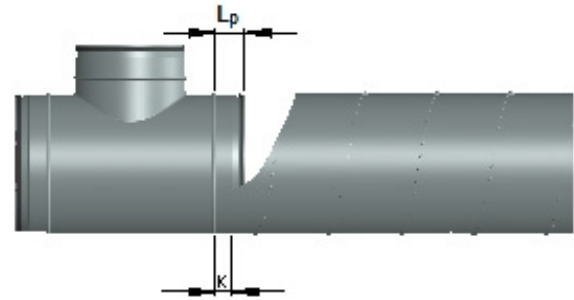

6. Simultaneous turning and pulling of a part of a duct will facilitate removal.

3. Supporting of air ducts

Air duct supports must ensure safe support for loads of ducts, insulation, duct equipment and smaller extra loads, i.e. occurring during maintenance, repair and construction works. Positioning of supports should not obstruct maintenance and adjustment or make them more complicated.

1. Place hangers as close to fitting points as possible, not more than 1 m away from fitting. Recommended hanger elements are threaded bars, ensuring the correct appearance of the installation. Supports are dimensioned with a safety factor of at least 1.5 (EVS-EN 12236:2002). Larger distances between supports can be found in the table (Table 3).
2. Attach ductwork on supports. Adjust the installation height as required.
3. If there are non-approved elements in the ductwork, these must be sealed to a density equal to the general density grade of the ductwork. Sealing material should be flexible, non-aging and must be compatible with BOSTIK 1600 or 1610.

Table 3.

Duct diameter, mm	Max. distance between supports, L m	Required hole diameter, mm
80	3	100
100	3	125
125	3	160
160	3	200
200	3	250
250	3	315
315	3	400
400	3	500
500	3	630
630	3	800
800	3	1000
1000	3	1250
1250	3	1500
1600	3	1850

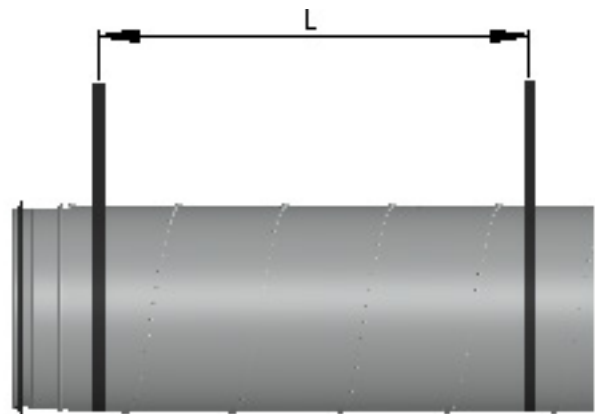

Maintenance

Ventilation systems should be regularly and properly cleaned from anything which may contaminate the air. Cleaning works have to do on a regular basis by the holder of the object by the deadlines set and in accordance with fire safety requirements.

To clean the ventilation ducts there must be maintenance doors in appropriate locations. Locations of maintenance doors must be chosen so that the cleaning work can be done easily and safely.