

DEZ paigaldus • installation • asennus

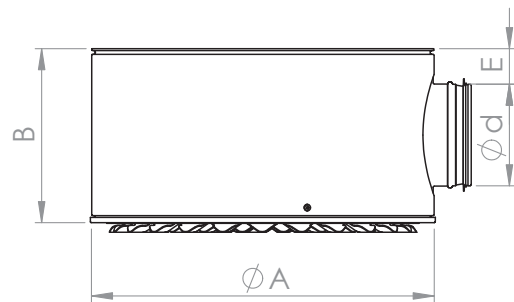

Nominal size	A	B	E	Nozzels	Weight kg
100	435	226	62	37	4,9
125	435	226	50	37	5,1
160	541	273	55	61	7,2
200	631	322	60	85	10,0
250	631	379	64	85	11,2
315	745	471	77	121	15,2

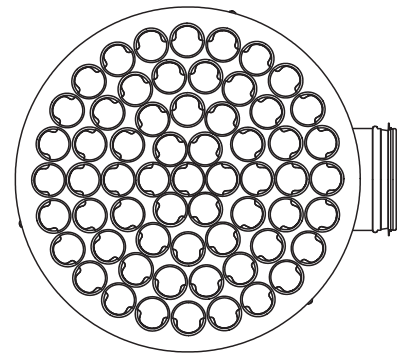
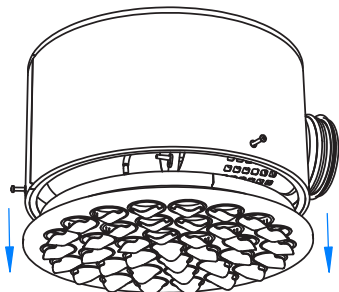
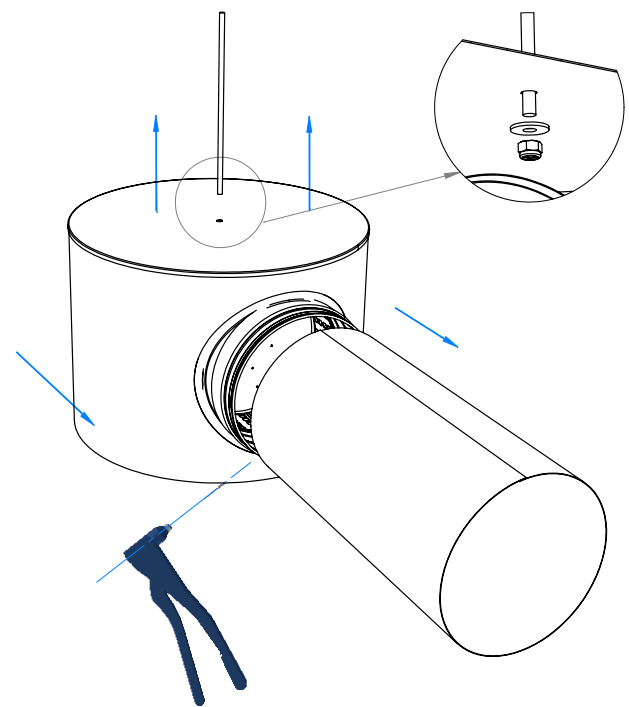
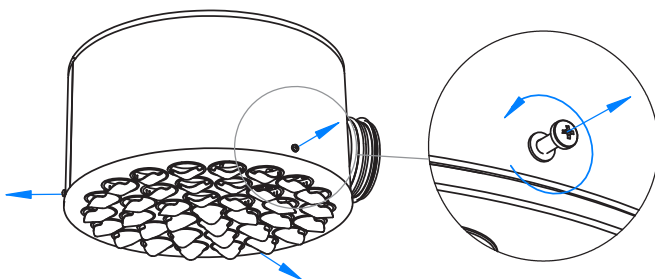

DEZ paigaldus • installation • asennus

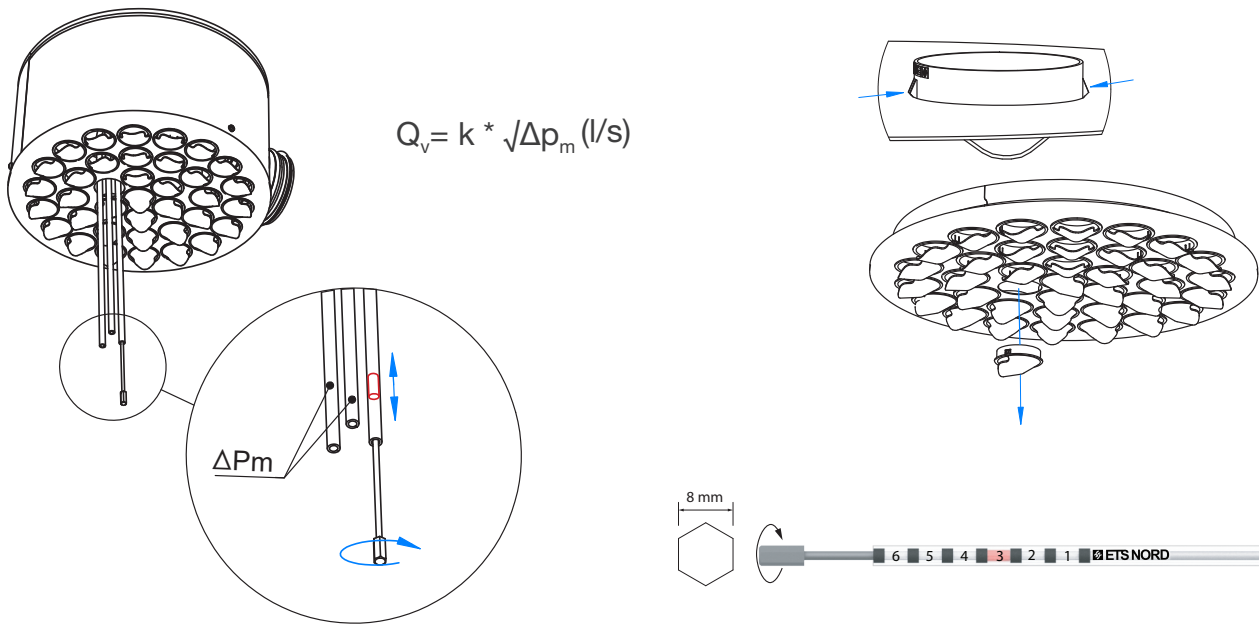

DEZ k-value

Nominal size	Position								
	1	2	3	4	5	6	7	8	
DEZ 100	2,0	4,0	5,9	7,5					
DEZ 125	2,1	4,1	6,0	7,9	9,5	10,7			
DEZ 160	3,5	6,7	9,9	12,9	15,6	17,7			
DEZ 200	5,1	9,9	14,7	19,4	23,6	26,8			
DEZ 250	6,3	12,5	18,5	24,4	30,0	35,3			
DEZ 315	7,4	14,2	21,5	29,0	36,0	43,1	50,0	56,4	

