



Technical Features



RAL 9016
standard



Other colors
on request



Maximum range
AC : 6 m EC : 8 m



Heating types
E : electrical 3 stages
P : water
A : unheated



Casing
Galvanised Steel



Airflow / Length
6400 - 20800 m³/h
1,5 m to 3,5 m



Heating capacity
E : 15 - 90 kW
P : 34,1 - 131,4 kW



Grille type
-



Fans
Axial
(Optional Atex) [*] Ex



Control
Without regulation. Optional:
(Advanced PRO + IR control)
(Clever PRO Control)



Outlet lamellas
Aluminium, airfoil type
Adjustable 0-15° each side

MAXWELL high performance air curtains for large industrial doors in industrial buildings, factories, loading bays, hangars or railway stations. For vertical or horizontal installation, they can be easily coupled together as dockable modules to reach large dimensions. Available in 1.5, 2.0, 2.5, 3.0 and 3.5 meters length.

With its double air discharge jet with Coanda effect they achieve longer distances more efficiently.

High efficiency and low noise axial fans, driven with external rotor motor single phase 230V. Optionally three phase 400V. Maintenance free.

Regulation not included. Optional: Advanced PRO control with LCD display and integrated thermostat, door contact, 10m RJ11 cable and remote control. Intelligent Clever PRO Control (automatic, programmable, modbus for PLC, timer, etc).

[*] Atex Fans: Optional high efficiency and low noise explosion proof axial fans Atex II 3G Ex h IIB T3 Gc X, driven with external rotor motor three phase 400V. "A" type without heating, air only. "P" type with water heated.

UNHEATED - 230Vx1

Model	Airflow m ³ /h	Ventilation power 230V~50Hz kW	Ventilation current 230V~50Hz A	Noise level (5 m) dB(A)	Weight kg
MXW 1500 A	7000	0,68	2,96	60	79
MXW 2000 A	10500	1,02	4,44	61	103
MXW 2500 A	14000	1,36	5,92	62	126
MXW 3000 A	17500	1,70	7,40	63	150
MXW 3500 A	20800	2,04	8,88	64	173

UNHEATED - 400Vx3

Model	Airflow m ³ /h	Ventilation power 400Vx3~50Hz kW	Ventilation current 400Vx3~50Hz A	Noise level (5 m) dB(A)	Weight kg
MXW 1500 A 400Vx3	7000	0,66	1,32	60	79
MXW 2000 A 400Vx3	10500	0,99	1,98	61	103
MXW 2500 A 400Vx3	14000	1,32	2,64	62	126
MXW 3000 A 400Vx3	17500	1,65	3,30	63	150
MXW 3500 A 400Vx3	20800	1,98	3,96	64	173



UNHEATED - EC Fans

Model	Airflow	Ventilation Power 230V~50Hz	Ventilation Current 230V~50Hz	Noise Level (5 m)	Weight
	m ³ /h	kW	A	dB(A)	kg
MXW EC 1500 A	9200	0,99	4,4	63	83
MXW EC 2000 A	13800	1,485	6,6	64	109
MXW EC 2500 A	18400	1,98	8,8	65	134
MXW EC 3000 A	23000	2,475	11	66	160
MXW EC 3500 A	27600	2,97	13,2	67	185

UNHEATED - ATEX Fans

Model	Airflow	Ventilation power 400Vx3~50Hz	Ventilation current 400Vx3~50Hz	Noise level (5 m)	Weight
	m ³ /h	kW	A	dB(A)	kg
MXW 1500 A EX-Fans	6400	0,64	1,50	60	79
MXW 2000 A EX-Fans	9600	0,96	2,25	61	103
MXW 2500 A EX-Fans	12800	1,28	3,00	62	126
MXW 3000 A EX-Fans	16000	1,60	3,75	63	150
MXW 3500 A EX-Fans	19200	1,92	4,50	64	173

ELECTRIC HEATED - Fan power supply 230Vx1

Model	Airflow	Electrical heating capacity 400Vx3~50Hz (*)	Ventilation power 230Vx1~50Hz	Ventilation current 230Vx1~50Hz	Noise level (5 m)	Weight
	m ³ /h	kW	kW	A	dB(A)	kg
MXW 1500 E	7000	15/22,5/37,5 (**)	0,68	2,96	60	96
MXW 2000 E	10500	20/30/50 (**)	1,02	4,44	61	133
MXW 2500 E	14000	30/40/70 (***)	1,36	5,92	62	167
MXW 3000 E	17500	30/50/80 (***)	1,70	7,40	63	201
MXW 3500 E	20800	30/60/90 (****)	2,04	8,88	64	231

ELECTRIC HEATED - Fan power supply 400Vx3

Model	Airflow	Electrical heating capacity 400Vx3~50Hz (*)	Ventilation power 400Vx3~50Hz	Ventilation current 400Vx3~50Hz	Noise level (5 m)	Weight
	m ³ /h	kW	kW	A	dB(A)	kg
MXW 1500 E 400Vx3	7000	15/22,5/37,5 (**)	0,66	1,32	60	96
MXW 2000 E 400Vx3	10500	20/30/50 (**)	0,99	1,98	61	133
MXW 2500 E 400Vx3	14000	30/40/70 (***)	1,32	2,64	62	167
MXW 3000 E 400Vx3	17500	30/50/80 (***)	1,65	3,30	63	201
MXW 3500 E 400Vx3	20800	30/60/90 (****)	1,98	3,96	64	231

(*) Under request other electrical heating power can be limited.

(**) 2 separated power supplies.

(***) 3 separated power supplies.

(****) The electrical 3500 heater incorporates the bars of length 3000 model.



ELECTRIC HEATED - EC Fans

Model	Airflow	Electrical heating capacity 400Vx3~50Hz (*)	Ventilation Power 230V~50Hz	Ventilation Current 230V~50Hz	Noise Level (5 m)	Weight
	m³/h	kW	kW	A	dB(A)	kg
MXW EC 1500 E	9200	15/22,5/37,5 (**)	0,99	4,4	63	96
MXW EC 2000 E	13800	20/30/50 (**)	1,485	6,6	64	133
MXW EC 2500 E	18400	30/40/70 (***)	1,98	8,8	65	167
MXW EC 3000 E	23000	30/50/80 (***)	2,475	11	66	201
MXW EC 3500 E	27600	30/60/90 (****)	2,97	13,2	67	233

(*) Under request other electrical heating power can be limited.

(**) 2 separated power supplies.

(***) 3 separated power supplies.

(****) The electrical 3500 heater incorporates the bars of length 3000 model.

WATER HEATED - 230Vx1

Model	Airflow	P86 (80/60°C)		P64 (60/40°C)		Ventilation power 230V~50Hz	Ventilation current 230V~50Hz	Noise level (5 m)	Weight
		Water heating capacity	Water pressure drop	Water heating capacity	Water pressure drop				
		kW	Pa	kW	Pa				
MXW 1500 P	6800	40,69	10150	34,09	12620	0,68	2,96	59	95
MXW 2000 P	10200	56,29	2180	50,16	13660	1,02	4,44	60	126
MXW 2500 P	13600	76,97	4730	66,19	14600	1,36	5,92	61	158
MXW 3000 P	17000	97,77	8640	82,22	14560	1,70	7,40	62	189
MXW 3500 P	20300	118,28	140080	97,92	14910	2,04	8,88	63	221

WATER HEATED - 400Vx3

Model	Airflow	P86 (80/60°C)		P64 (60/40°C)		Ventilation power 400Vx3~50Hz	Ventilation current 400Vx3~50Hz	Noise level (5 m)	Weight
		Water heating capacity	Water pressure drop	Water heating capacity	Water pressure drop				
		kW	Pa	kW	Pa				
MXW 1500 P 400Vx3	6800	40,69	10150	34,09	12620	0,66	1,32	59	95
MXW 2000 P 400Vx3	10200	56,29	2180	50,16	13660	0,99	1,98	60	126
MXW 2500 P 400Vx3	13600	76,97	4730	66,19	14600	1,32	2,64	61	158
MXW 3000 P 400Vx3	17000	97,77	8640	82,22	14560	1,65	3,30	62	189
MXW 3500 P 400Vx3	20300	118,28	140080	97,92	14910	1,98	3,96	63	221

WATER HEATED - EC Fans

Model	Airflow	P86 (80/60°C)		P64 (60/40°C)		Ventilation Power 230V~50Hz	Ventilation Current 230V~50Hz	Noise Level (5 m)	Weight
		Water Heating Capacity	Water Pressure Drop	Water Heating Capacity	Water Pressure Drop				
		kW	Pa	kW	Pa				
MXW EC 1500 P	8600	47,72	15490	39,6	16450	0,99	4,4	62	99
MXW EC 2000 P	12900	64,77	2800	58,2	17770	1,485	6,6	63	132
MXW EC 2500 P	17200	87,02	5880	75,36	18370	1,98	8,8	64	164
MXW EC 3000 P	21500	109,36	10540	92,53	17940	2,475	11	65	199
MXW EC 3500 P	25800	131,42	16970	110,14	18960	2,97	13,2	66	233



WATER HEATED - ATEX Fans

Model	Airflow m ³ /h	P86 (80/60°C)		P64 (60/40°C)		Ventilation power 400Vx3~50Hz kW	Ventilation current 400Vx3~50Hz A	Noise level (5 m) dB(A)	Weight kg
		Water heating capacity kW	Water pressure drop Pa	Water heating capacity kW	Water pressure drop Pa				
MXW 1500 P EX Fans	6400	39,88	11270	32,78	11780	0,74	2,24	59	95
MXW 2000 P EX Fans	9600	54,26	2040	47,74	11820	1,11	3,36	60	126
MXW 2500 P EX Fans	12800	74,21	4430	63,38	13630	1,48	4,48	61	158
MXW 3000 P EX Fans	16000	94,26	8100	79,11	13630	1,85	5,60	62	189
MXW 3500 P EX Fans	19200	114,35	13260	94,50	14000	2,22	6,72	63	221

Water heated:

P86 2 rows coil, P64 3 rows coil

2x1 1/4" for all models.

Connection pipes P86 and P64 are female (male if lateral pipes).



Selection program

Dimensions

Horizontal installation
Water heated / unheated

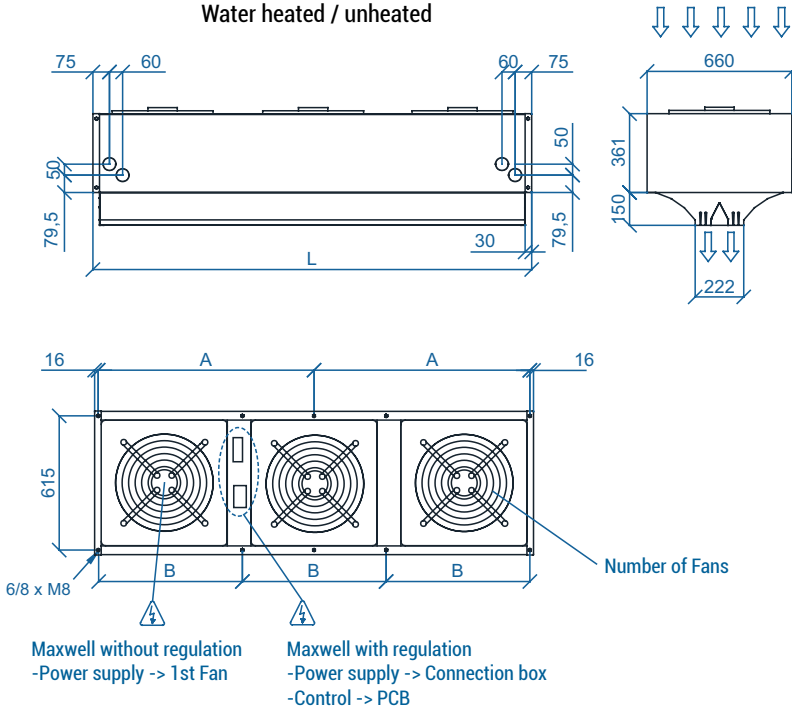

Vertical installation
Water heated / unheated

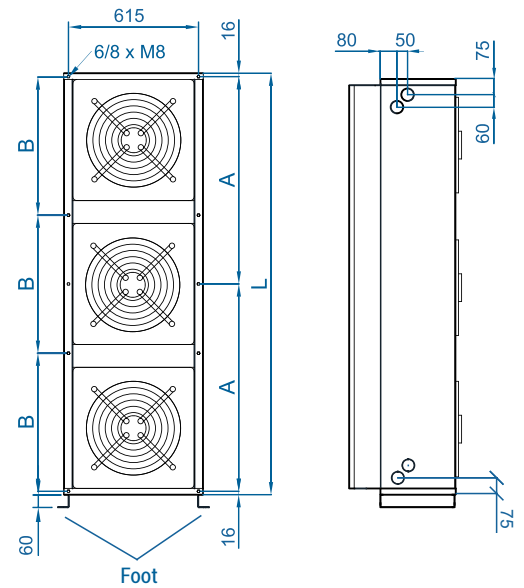

	L	A	B	Fans
MXW 1500	1500	734	-	2
MXW 2000	2000	984	-	3
MXW 2500	2500	1234	-	4
MXW 3000	3040	-	1002,5	5
MXW 3500	3620	-	1196	6



Horizontal installation
Electrical heated

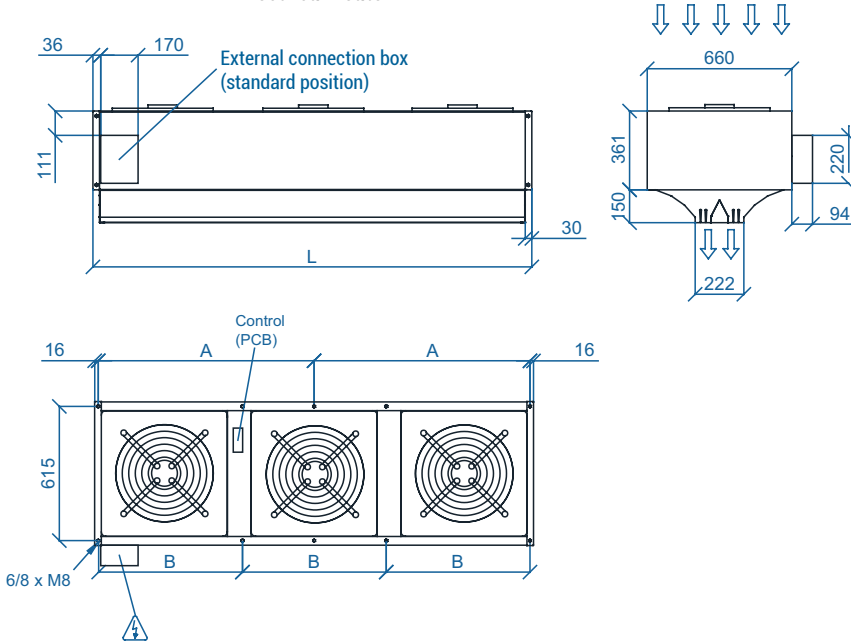

Vertical installation
Electrical heated

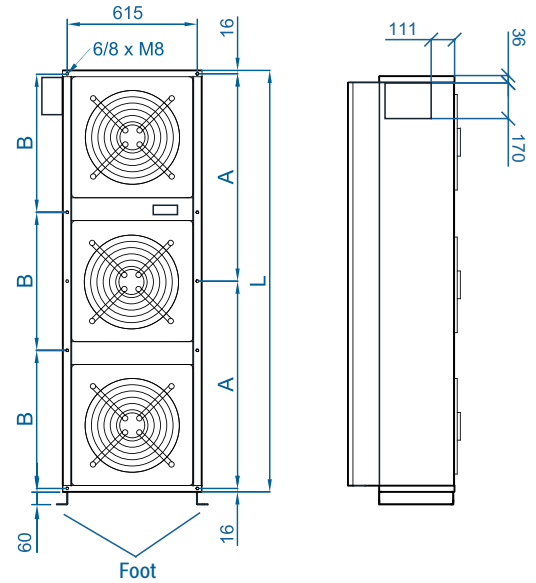

ATEX fans dimensions

Horizontal installation
Water heated / unheated

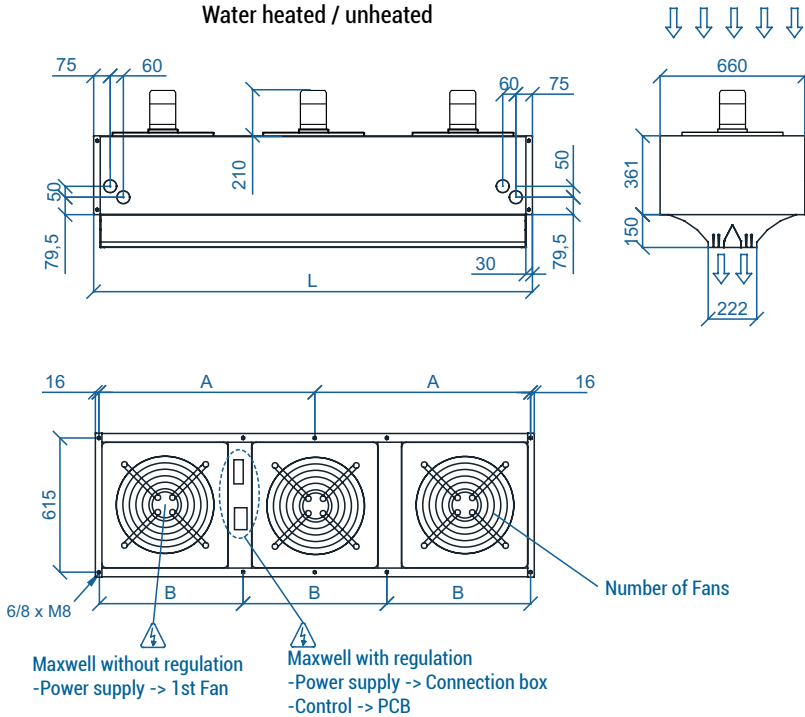

Vertical installation
Water heated / unheated

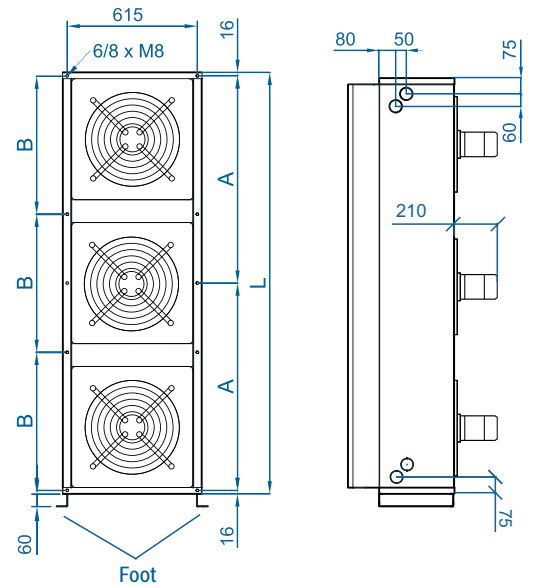

	L	A	B	Fans
MXW 1500	1500	734	-	2
MXW 2000	2000	984	-	3
MXW 2500	2500	1234	-	4
MXW 3000	3040	-	1002,5	5
MXW 3500	3620	-	1196	6



Coanda Effect

The main characteristic of MAXWELL air curtain outlet is its double blow-out jet with Coanda effect. This airflow distribution permits to achieve larger and more efficient air jet. Moreover, it is a compact and versatile air curtain, available in several lengths that can be easily combined to reach large dimensions.

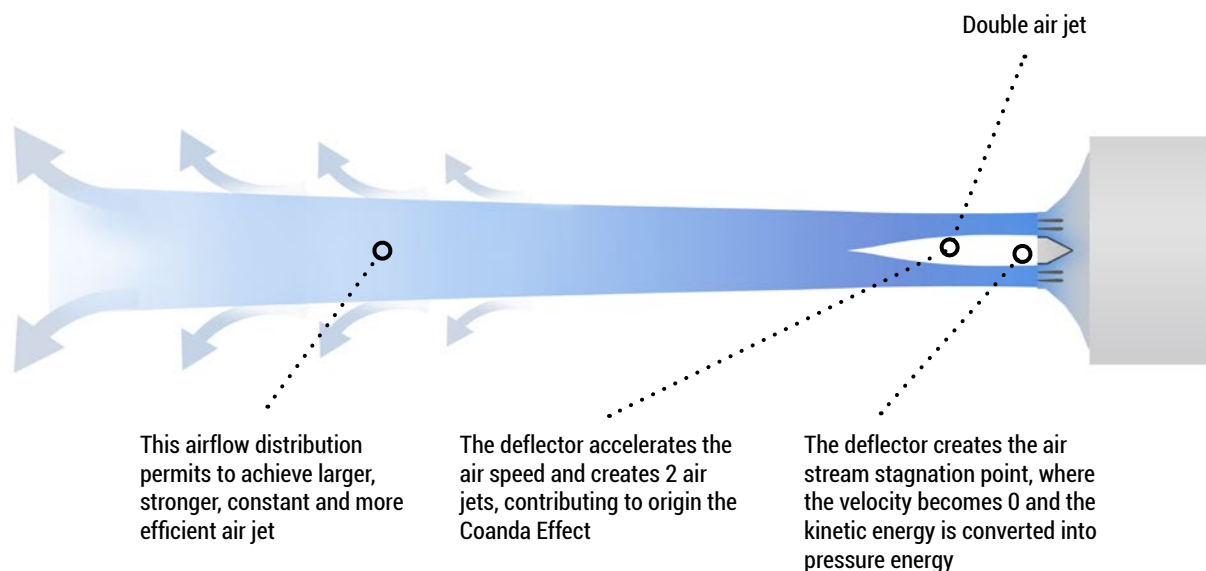

Optional Accessories

Supports and installation



Wall rail support
SPWR



Silentblock supports
SPANG-SIL / SLB



Suspension cables
SPCT



Foot support
SPF-MXW
(Galv. / SS)



Joining kit
SPJ-MXW
(Galv. / SS)

Control



ADVANCED PRO



IR Control



RJ11 Cable



CLEVER PRO

Sensors and valves



Magnetic door contact
MAG-DC



Mechanical door contact
MEC-DC



External Temperature
Sensor



Solenoid valve
V-S



Valve 3 ways
V-T



Proportional valve
V-ACT