



# ENVIRONMENTAL PRODUCT DECLARATION

IN ACCORDANCE WITH EN 15804+A2 & ISO 14025

NORDdiffuser / AIR DISTRIBUTOR  
ETS NORD AS



## EPD HUB, HUB-6354

Published on 22.05.2026, last updated on 22.05.2026, valid until 21.05.2031

Life Cycle Assessment study has been performed in accordance with the requirements of EN 15804, EPD Hub PCR version 1.2 (24 Mar 2025) and JRC characterization factors EF 3.1.

## GENERAL INFORMATION

### MANUFACTURER

Manufacturer	ETS NORD AS
Address	Peterburi tee 53, Tallinn, Estonia
Contact details	info@etsnord.com
Website	<a href="https://www.etsnord.com/">https://www.etsnord.com/</a>

### EPD STANDARDS, SCOPE AND VERIFICATION

Program operator	EPD Hub, hub@epdhub.com
Reference standard	EN 15804:2012+A2:2019/AC:2021 and ISO 14025
PCR	EPD Hub Core PCR Version 1.2, 24 Mar 2025 EN 17662:2021 Execution of steel structures and aluminium structures
Sector	Construction product
Category of EPD	Third party verified EPD
Scope of the EPD	Cradle to gate with options, A4-A5, and modules C1-C4, D
EPD author	Mari-Liis Tommula, LCA Support
EPD verification	Independent verification of this EPD and data, according to ISO 14025:  <input type="checkbox"/> Internal verification <input checked="" type="checkbox"/> External verification
EPD verifier	Haiha Nguyen, as an authorized verifier acting for EPD Hub Limited

This EPD is intended for business-to-business and/or business-to-consumer communication. The manufacturer has the sole ownership, liability, and responsibility for the EPD. EPDs within the same product category but from different programs may not be comparable. EPDs of construction products may not be comparable if they do not comply with EN 15804 and if they are not compared in a building context.

## PRODUCT

Product name	AIR DISTRIBUTOR
Product reference	DDR
Place(s) of raw material origin	Europe
Place of production	Tallinn, Estonia
Place(s) of installation and use	Global
Period for data	01.01.2024 - 31.12.2024
Averaging in EPD	No grouping
A1-A3 Specific data (%)	49

## ENVIRONMENTAL DATA SUMMARY

Declared unit	1 kg of product
Declared unit mass	1 kg
Mass of packaging	0,41 kg
GWP-fossil, A1-A3 (kgCO <sub>2</sub> e)	5,25
GWP-total, A1-A3 (kgCO <sub>2</sub> e)	4,86
Secondary material, inputs (%)	6,47
Secondary material, outputs (%)	90
Total energy use, A1-A3 (kWh)	23,4
Net freshwater use, A1-A3 (m <sup>3</sup> )	0,31

# PRODUCT AND MANUFACTURER

## ABOUT THE MANUFACTURER

ETS NORD is one of the largest companies in Northern Europe specializing in comprehensive ventilation solutions, operating since 1998. Our company has a well-defined mission that represent our operations: Improving the living environment by creating the best indoor air solutions.

With significant product development and our own production, we are at the forefront of creating a new and sustainable future for indoor comfort, in a customer-oriented and responsible way. By listening and engaging, we take into account the needs of our customers and are able to offer products and solutions that meet their needs.

Our team of 500 highly skilled and dedicated professionals serves you in four different countries. We are an experienced and reliable partner from the planning phase of the project to the installation and technical maintenance of the products.

## PRODUCT DESCRIPTION

The NORDDiffuser product group contains all the necessary terminal devices for supply and exhaust air systems - both valves and air diffusers. Air diffusers for residential constructions also act as smoke traps.

The NORDDiffuser air distribution devices are designed to be stylishly unnoticeable, blending in smoothly with the surrounding environment. The air diffusers are made of standard hot-dip galvanized sheet steel and painted white with powder paint (RAL 9003). The air diffusers can also be manufactured of special materials and coated with the colour indicated by the customer.

Technical specifications and product standards

EVS-EN 12238:2001 Ventilation for buildings - Air terminal devices -

Aerodynamic testing and rating for mixed flow application

EVS-EN-ISO 5135:2020 Acoustics – Determination of sound power levels of

noise from air terminal devices, high/low velocity / pressure assemblies, dampers and valves by measurement in a reverberation room--

EVS-EN 1506:2007 Ventilation for buildings - Sheet metal air ducts and fittings with circular cross-section - Dimensions

EVS-EN 10346:2015 Continuously hot-dip coated steel flat products - Technical delivery conditions

EVS-EN 485-1:2016 Aluminium and aluminium alloys - Sheet, strip and plate - Part 1: Technical conditions for inspection and delivery

- The products fulfill the Regulation no. 49 (26.07.2013) requirements.
- The products are suitable for use in the atmospheric corrosivity categories C1 to C4 according to ISO 9223:2012.

Further information can be found at:

<https://www.etsnord.com/>

## PRODUCT RAW MATERIAL MAIN COMPOSITION

Raw material category	Amount, mass %	Material origin
Metals	97	Europe
Minerals	0	N/A
Fossil materials	3	Europe
Bio-based materials	0	N/A

## BIOGENIC CARBON CONTENT

Product's biogenic carbon content at the factory gate

Biogenic carbon content in product, kg C	0
Biogenic carbon content in packaging, kg C	0,17

### DECLARED UNIT

Declared unit	1 kg of product
Mass per declared unit	1 kg

### SUBSTANCES, REACH - VERY HIGH CONCERN

The product does not contain any REACH SVHC substances in amounts greater than 0,1 % (1000 ppm).

# PRODUCT LIFE-CYCLE

## SYSTEM BOUNDARY

This EPD covers the life-cycle modules listed in the following table.

Cradle to gate with options, A4-A5 and modules C1-C4, D.

Product stage			Assembly stage		Use stage							End of life stage				Beyond the system boundaries		
A1	A2	A3	A4	A5	B1	B2	B3	B4	B5	B6	B7	C1	C2	C3	C4	D		
X	X	X	X	X	ND	ND	ND	ND	ND	ND	ND	X	X	X	X	X		
Raw materials	Transport	Manufacturing	Transport	Assembly	Use	Maintenance	Repair	Replacement	Refurbishment	Operational energy use	Operational water use	Deconstruction/ demolition	Transport	Waste processing	Disposal	Reuse	Recovery	Recycling

Not declared = ND.

## MANUFACTURING AND PACKAGING (A1-A3)

The environmental impacts considered for the product stage cover the manufacturing of raw materials used in the production as well as packaging materials and other ancillary materials. Also, fuels used by machines, and handling of waste formed in the production processes at the manufacturing facilities are included in this stage. The study also considers the material losses occurring during the manufacturing processes as well as losses during electricity transmission.

A market-based approach is used in modelling the electricity mix utilized in the factory. The manufacturing site is equipped with an onsite rooftop photovoltaic system.

The manufacturing process begins with cutting, where raw materials are cut to the required dimensions using mechanical cutting methods.

After cutting, the components proceed to the bending stage. During this phase, the parts are bent and formed to achieve the required shapes and geometries according to product specifications.

Following bending, the components are sent to the painting stage. Surface treatment and coating are applied to provide the required finish and corrosion protection.

Once painting is completed, the components move to the assembly stage. Individual parts are assembled, and all functional elements are installed to form the finished product.

After assembly, the products undergo testing to verify functionality, dimensional accuracy, and compliance with applicable requirements.

In the final stage, the tested products are packaged. Each unit is placed into protective packaging and prepared for transport, after which the products are palletized and made ready for shipment.

For packaging products, we use corrugated cardboard boxes made from multi-layer board. The boxes are mechanically cut, folded and glued by the packaging supplier and delivered to us in flat form. During our packaging process, the boxes are opened, filled with the required number of regulating dampers, and then closed and placed onto pallets for transport.

## TRANSPORT AND INSTALLATION (A4-A5)

Transportation impacts occurred from final products delivery to construction site (A4) cover fuel direct exhaust emissions, environmental impacts of fuel production, as well as related infrastructure emissions.

The product is sold globally, however, the primary target market is Finland, and therefore the transport scenario has been defined accordingly. The average transportation distance from the production plant to the final client in Helsinki, Finland is 130 km (80 km by ferry, 50 km by lorry). The transportation method is assumed to be a lorry 16-32t, which is the most common way of transport in the region. According to the manufacturer, transportation doesn't cause losses as products are packaged properly. Vehicle capacity utilization volume factor is assumed to be 1.

The impacts of product installation have not been assessed, as the quantities of fixing materials used vary depending on the building structure, and site-specific conditions.

Packaging waste treatment has been included. It is assumed that the wooden pallet is incinerated (Nordic council of Ministers, 2022). Plastic packaging is assumed to be incinerated with energy recovery (Eurostat, 2020). Waste paperboard is assumed to be recycled, as the most common treatment option for paper waste in Finland, where approximately 54% of paper waste is recycled (Eurostat, 2024).

## PRODUCT USE AND MAINTENANCE (B1-B7)

This EPD does not cover the use phase.

Air, soil, and water impacts during the use phase have not been studied.

## PRODUCT END OF LIFE (C1-C4, D)

The demolition is assumed to require 1.1 kWh of energy per tonne of product. It is assumed that 100% of the product is collected and transported

50 km to closest treatment facility. 90% of metal is sent to recycling and 10% of metal is assumed to be landfilled (EuRIC, 2019).

Any material that left the product system in C3 has been considered in module D. Only net flows are considered. Waste packaging from A5 has also been considered. Module D scenario is representative of Europe.

# SYSTEM BOUNDARY

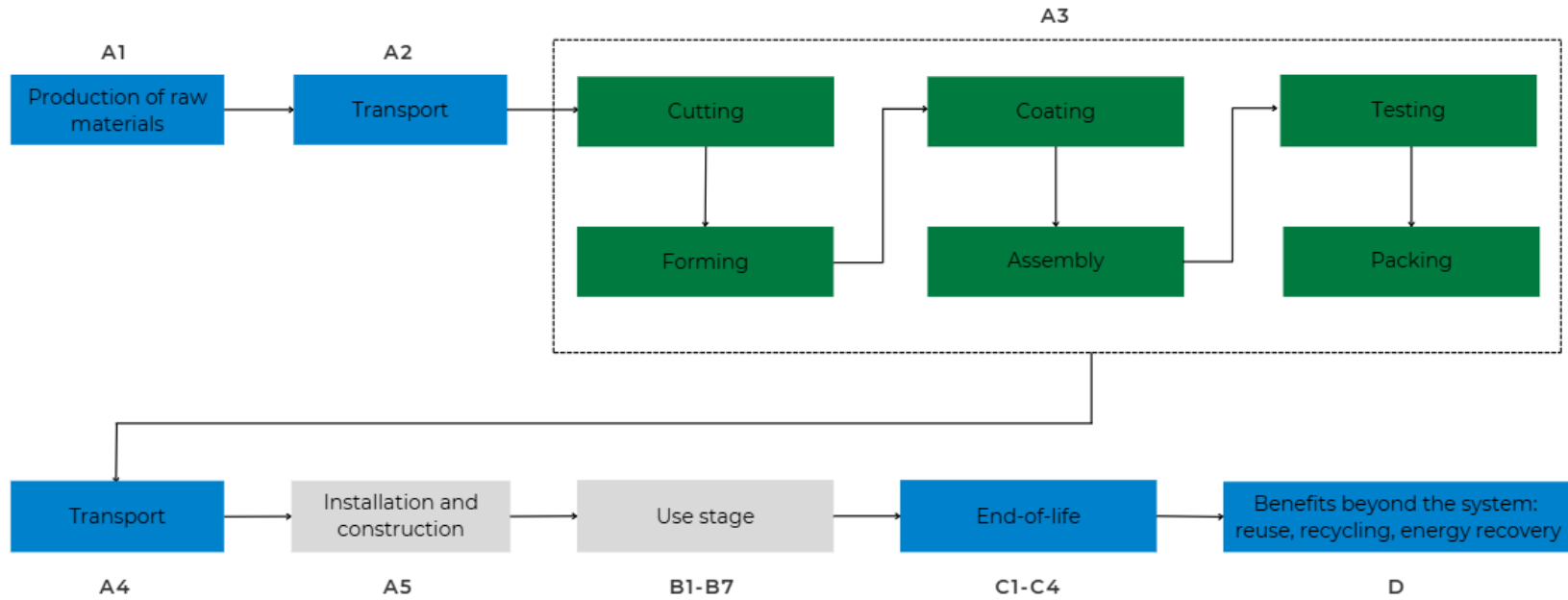

LEGEND:

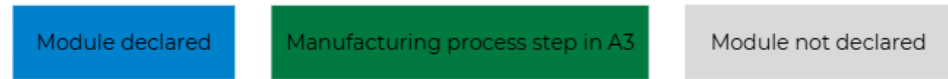

## LIFE-CYCLE ASSESSMENT

### CUT-OFF CRITERIA

The study does not exclude any modules or processes which are stated mandatory in the reference standard and the applied PCR. The study does not exclude any hazardous materials or substances. The study includes all major raw material and energy consumption. All inputs and outputs of the unit processes, for which data is available for, are included in the calculation. There is no neglected unit process more than 1% of total mass or energy flows. The module specific total neglected input and output flows also do not exceed 5% of energy usage or mass.

The production of capital equipment, construction activities, and infrastructure, maintenance and operation of capital equipment, personnel-related activities, energy and water use related to company management and sales activities are excluded.

### VALIDATION OF DATA

Data collection for production, transport, and packaging was conducted using time and site-specific information, as defined in the general information section on page 2. Upstream process calculations rely on generic data as defined in the Bibliography section. Manufacturer-provided specific and generic data were used for the product's manufacturing stage. The analysis was performed in One Click LCA EPD Generator, with the 'Cut-Off, EN 15804+A2' allocation method, and characterization factors according to EN 15804:2012+A2:2019/AC:2021 and JRC EF 3.1.

### ALLOCATION, ESTIMATES AND ASSUMPTIONS

Allocation is required if some material, energy, and waste data cannot be measured separately for the product under investigation. All allocations are done as per the reference standards and the applied PCR. In this study, allocation has been done in the following ways:

Data type	Allocation
Raw materials	No allocation
Packaging material	No allocation
Ancillary materials	No allocation
Manufacturing energy and waste	Allocated by mass

### PRODUCT & MANUFACTURING SITES GROUPING

Type of grouping	No grouping
------------------	-------------

This EPD is product and factory specific.

## LCA SOFTWARE AND BIBLIOGRAPHY

This EPD has been created using One Click LCA EPD Generator for EPD Hub V3 and EPD Process Certification v3.2.3. The LCA and EPD have been prepared according to the reference standards and ISO 14040/14044. The EPD Generator uses Ecoinvent v3.10.1/3.11 and One Click LCA databases as sources of environmental data. Allocation used in Ecoinvent 3.10.1/3.11 environmental data sources follow the methodology 'allocation, Cut-off, EN 15804+A2'.

EuRIC (2019). Metal Recycling Factsheet. European Recycling Industries' Confederation. Accessed:  
[https://circulareconomy.europa.eu/platform/sites/default/files/euric\\_metal\\_recycling\\_factsheet.pdf](https://circulareconomy.europa.eu/platform/sites/default/files/euric_metal_recycling_factsheet.pdf)

Statistics Finland (2025) Waste statistics. PxWeb. Available at:  
[https://pxdata.stat.fi/PxWeb/pxweb/en/StatFin/StatFin\\_\\_jate/statfin\\_jate\\_pxt\\_12qy.px/table/tableViewLayout1/](https://pxdata.stat.fi/PxWeb/pxweb/en/StatFin/StatFin__jate/statfin_jate_pxt_12qy.px/table/tableViewLayout1/)

# ENVIRONMENTAL IMPACT DATA

The estimated impact results are only relative statements which do not indicate the end points of the impact categories, exceeding threshold values, safety margins or risks.

## CORE ENVIRONMENTAL IMPACT INDICATORS – EN 15804+A2, EF 3.1

Impact category	Unit	A1	A2	A3	A1-A3	A4	A5	B1	B2	B3	B4	B5	B6	B7	C1	C2	C3	C4	D
GWP – total <sup>1)</sup>	kg CO <sub>2</sub> e	4,74E+00	2,33E-01	-1,11E-01	4,86E+00	2,68E-02	5,11E-01	ND	ND	ND	ND	ND	ND	ND	3,99E-04	9,44E-03	5,67E-02	5,87E-04	-3,34E+00
GWP – fossil	kg CO <sub>2</sub> e	4,66E+00	2,32E-01	3,59E-01	5,25E+00	2,68E-02	3,42E-02	ND	ND	ND	ND	ND	ND	ND	3,98E-04	9,43E-03	5,67E-02	5,87E-04	-3,30E+00
GWP – biogenic	kg CO <sub>2</sub> e	3,40E-02	5,05E-05	-4,75E-01	-4,41E-01	4,62E-06	4,77E-01	ND	ND	ND	ND	ND	ND	ND	6,45E-08	1,90E-06	-6,86E-05	-7,17E-08	-8,41E-03
GWP – LULUC	kg CO <sub>2</sub> e	4,34E-02	9,06E-05	5,03E-03	4,85E-02	1,14E-05	3,81E-06	ND	ND	ND	ND	ND	ND	ND	4,03E-08	3,39E-06	4,02E-05	3,36E-07	-3,39E-02
Ozone depletion pot.	kg CFC-11e	4,81E-07	4,84E-09	1,29E-08	4,99E-07	4,60E-10	1,13E-10	ND	ND	ND	ND	ND	ND	ND	6,13E-12	1,88E-10	6,00E-10	1,68E-11	-4,77E-08
Acidification potential	mol H <sup>+</sup> e	2,11E-02	5,86E-04	1,97E-03	2,37E-02	4,27E-04	6,44E-05	ND	ND	ND	ND	ND	ND	ND	3,56E-06	1,96E-05	3,33E-04	4,15E-06	-1,41E-02
EP-freshwater <sup>2)</sup>	kg Pe	1,24E-03	1,62E-05	1,11E-04	1,37E-03	1,29E-06	3,03E-06	ND	ND	ND	ND	ND	ND	ND	1,28E-08	6,35E-07	2,19E-05	4,91E-08	-1,85E-03
EP-marine	kg Ne	3,74E-03	1,53E-04	6,05E-04	4,50E-03	1,07E-04	3,14E-05	ND	ND	ND	ND	ND	ND	ND	1,67E-06	4,71E-06	6,00E-05	1,58E-06	-2,69E-03
EP-terrestrial	mol Ne	3,72E-02	1,66E-03	5,44E-03	4,43E-02	1,19E-03	2,94E-04	ND	ND	ND	ND	ND	ND	ND	1,82E-05	5,09E-05	6,73E-04	1,73E-05	-2,62E-02
POCP (“smog”) <sup>3)</sup>	kg NMVOCe	1,36E-02	9,79E-04	1,82E-03	1,64E-02	3,48E-04	7,98E-05	ND	ND	ND	ND	ND	ND	ND	5,47E-06	3,27E-05	2,06E-04	6,21E-06	-1,01E-02
ADP-minerals & metals <sup>4)</sup>	kg Sbe	3,19E-05	6,62E-07	1,48E-06	3,40E-05	5,64E-08	4,25E-08	ND	ND	ND	ND	ND	ND	ND	1,45E-10	3,14E-08	2,17E-06	9,18E-10	3,20E-06
ADP-fossil resources	MJ	5,83E+01	3,49E+00	5,59E+00	6,74E+01	3,53E-01	9,26E-02	ND	ND	ND	ND	ND	ND	ND	5,17E-03	1,33E-01	4,74E-01	1,44E-02	-4,67E+01
Water use <sup>5)</sup>	m <sup>3</sup> e depr.	1,34E+01	1,78E-02	3,17E+00	1,66E+01	1,36E-03	1,11E-02	ND	ND	ND	ND	ND	ND	ND	1,30E-05	6,60E-04	1,06E-02	1,92E-04	-3,25E+00

1) GWP = Global Warming Potential; 2) EP = Eutrophication potential. Required characterisation method and data are in kg P-eq. Multiply by 3,07 to get PO4e; 3) POCP = Photochemical ozone formation; 4) ADP = Abiotic depletion potential; 5) EN 15804+A2 disclaimer for Abiotic depletion and Water use and optional indicators except Particulate matter and Ionizing radiation, human health. The results of these environmental impact indicators shall be used with care as the uncertainties on these results are high or as there is limited experience with the indicator.

## USE OF NATURAL RESOURCES

Impact category	Unit	A1	A2	A3	A1-A3	A4	A5	B1	B2	B3	B4	B5	B6	B7	C1	C2	C3	C4	D
Renew. PER as energy <sup>8)</sup>	MJ	1,30E+01	5,66E-02	3,89E+00	1,70E+01	4,43E-03	-6,71E+00	ND	ND	ND	ND	ND	ND	ND	3,23E-05	2,32E-03	8,03E-02	1,38E-04	-1,09E+01
Renew. PER as material	MJ	2,73E-05	0,00E+00	5,85E+00	5,85E+00	0,00E+00	-5,85E+00	ND	ND	ND	ND	ND	ND	ND	0,00E+00	0,00E+00	0,00E+00	-2,60E-05	0,00E+00
Total use of renew. PER	MJ	1,30E+01	5,66E-02	9,74E+00	2,28E+01	4,43E-03	-1,26E+01	ND	ND	ND	ND	ND	ND	ND	3,23E-05	2,32E-03	8,03E-02	1,12E-04	-1,09E+01
Non-re. PER as energy	MJ	5,84E+01	3,49E+00	5,13E+00	6,70E+01	3,53E-01	-2,19E-01	ND	ND	ND	ND	ND	ND	ND	5,17E-03	1,33E-01	4,74E-01	1,44E-02	-4,66E+01
Non-re. PER as material	MJ	1,12E-07	0,00E+00	6,37E-01	6,37E-01	0,00E+00	-6,37E-01	ND	ND	ND	ND	ND	ND	ND	0,00E+00	0,00E+00	0,00E+00	-1,06E-07	0,00E+00
Total use of non-re. PER	MJ	5,84E+01	3,49E+00	5,76E+00	6,77E+01	3,53E-01	-8,57E-01	ND	ND	ND	ND	ND	ND	ND	5,17E-03	1,33E-01	4,74E-01	1,44E-02	-4,66E+01
Secondary materials	kg	6,47E-02	1,51E-03	1,25E-01	1,92E-01	1,59E-04	1,70E-04	ND	ND	ND	ND	ND	ND	ND	2,14E-06	6,16E-05	4,48E-04	3,61E-06	5,67E-02
Renew. secondary fuels	MJ	2,53E-04	1,89E-05	1,60E-01	1,60E-01	1,26E-06	7,62E-07	ND	ND	ND	ND	ND	ND	ND	5,62E-09	7,79E-07	1,84E-05	7,49E-08	-2,25E-04
Non-ren. secondary fuels	MJ	0,00E+00	0,00E+00	0,00E+00	0,00E+00	0,00E+00	0,00E+00	ND	ND	ND	ND	ND	ND	ND	0,00E+00	0,00E+00	0,00E+00	0,00E+00	0,00E+00
Use of net fresh water	m <sup>3</sup>	3,08E-01	5,13E-04	4,48E-03	3,13E-01	3,61E-05	7,66E-05	ND	ND	ND	ND	ND	ND	ND	3,11E-07	1,81E-05	2,49E-04	1,50E-05	-6,86E-02

8) PER = Primary energy resources.

## END OF LIFE – WASTE

Impact category	Unit	A1	A2	A3	A1-A3	A4	A5	B1	B2	B3	B4	B5	B6	B7	C1	C2	C3	C4	D
Hazardous waste	kg	5,79E-01	5,04E-03	1,58E-02	6,00E-01	4,74E-04	3,24E-03	ND	ND	ND	ND	ND	ND	ND	1,68E-05	1,93E-04	5,50E-03	1,60E-05	-1,02E+00
Non-hazardous waste	kg	7,15E+00	1,01E-01	5,20E-01	7,78E+00	8,46E-03	3,19E-01	ND	ND	ND	ND	ND	ND	ND	8,36E-05	4,07E-03	1,69E-01	3,68E-04	-8,70E+00
Radioactive waste	kg	5,43E-04	1,04E-06	1,03E-05	5,54E-04	7,65E-08	7,90E-08	ND	ND	ND	ND	ND	ND	ND	5,08E-10	4,25E-08	1,13E-06	2,18E-09	-1,24E-04

## END OF LIFE – OUTPUT FLOWS

Impact category	Unit	A1	A2	A3	A1-A3	A4	A5	B1	B2	B3	B4	B5	B6	B7	C1	C2	C3	C4	D
Components for re-use	kg	0,00E+00	0,00E+00	0,00E+00	0,00E+00	0,00E+00	0,00E+00	ND	ND	ND	ND	ND	ND	ND	0,00E+00	0,00E+00	0,00E+00	0,00E+00	0,00E+00
Materials for recycling	kg	0,00E+00	0,00E+00	7,40E-02	7,40E-02	0,00E+00	1,10E-01	ND	ND	ND	ND	ND	ND	ND	0,00E+00	0,00E+00	9,00E-01	0,00E+00	0,00E+00
Materials for energy rec	kg	0,00E+00	0,00E+00	2,20E-22	2,20E-22	0,00E+00	3,01E-01	ND	ND	ND	ND	ND	ND	ND	0,00E+00	0,00E+00	0,00E+00	0,00E+00	0,00E+00
Exported energy	MJ	0,00E+00	0,00E+00	0,00E+00	0,00E+00	0,00E+00	5,85E+00	ND	ND	ND	ND	ND	ND	ND	0,00E+00	0,00E+00	0,00E+00	0,00E+00	0,00E+00
Exported energy – Electricity	MJ	0,00E+00	0,00E+00	0,00E+00	0,00E+00	0,00E+00	1,95E+00	ND	ND	ND	ND	ND	ND	ND	0,00E+00	0,00E+00	0,00E+00	0,00E+00	0,00E+00
Exported energy – Heat	MJ	0,00E+00	0,00E+00	0,00E+00	0,00E+00	0,00E+00	3,90E+00	ND	ND	ND	ND	ND	ND	ND	0,00E+00	0,00E+00	0,00E+00	0,00E+00	0,00E+00

## ADDITIONAL INDICATOR – GWP-GHG

Impact category	Unit	A1	A2	A3	A1-A3	A4	A5	B1	B2	B3	B4	B5	B6	B7	C1	C2	C3	C4	D
GWP-GHG <sup>9)</sup>	kg CO <sub>2</sub> e	4,71E+00	2,33E-01	3,64E-01	5,30E+00	2,68E-02	3,42E-02	ND	ND	ND	ND	ND	ND	ND	3,99E-04	9,44E-03	5,68E-02	5,87E-04	-3,33E+00

9) This indicator includes all greenhouse gases excluding biogenic carbon dioxide uptake and emissions and biogenic carbon stored in the product. In addition, the characterisation factors for the flows – CH<sub>4</sub> fossil, CH<sub>4</sub> biogenic and Dinitrogen monoxide – were updated. This indicator is identical to the GWP-total of EN 15804:2012+A2:2019 except that the characterisation factor for biogenic CO<sub>2</sub> is set to zero.

## SCENARIO DOCUMENTATION

### DATA SOURCES

#### Manufacturing energy scenario documentation

Scenario parameter	Value
Electricity data source and quality	1. Electricity, Estonia, residual mix, 2024, Estonia, One Click LCA 2. Electricity production, photovoltaic, 3kWp flat-roof installation, single-Si, World, Ecoinvent
Electricity CO2e / kWh	1. 0,6 2. 0,0843
District heating data source and quality	3. District Heat, Estonia, 2023, Estonia, One Click LCA
District heating CO2e / kWh	0,078

#### Transport scenario documentation A4

Scenario parameter	Value
Fuel and vehicle type. Eg, electric truck, diesel powered truck	Diesel powered truck, EURO6 Ferry
Average transport distance, km	50 km (truck), 80 km (ferry)
Capacity utilization (including empty return) %	100
Bulk density of transported products	N/A
Volume capacity utilization factor	1

#### End of life scenario documentation

Scenario information	Value
Collection process – kg collected separately	1
Collection process – kg collected with mixed waste	0
Recovery process – kg for re-use	0
Recovery process – kg for recycling	0,9
Recovery process – kg for energy recovery	0
Disposal (total) – kg for final deposition	0,1
Scenario assumptions e.g. transportation	Transport to treatment or landfill is assumed to be 50 km.

## THIRD-PARTY VERIFICATION STATEMENT

EPD Hub declares that this EPD is verified in accordance with ISO 14025 by an independent, third-party verifier. The project report on the Life Cycle Assessment and the report(s) on features of environmental relevance are filed at EPD Hub. EPD Hub PCR and ECO Platform verification checklist are used.

EPD Hub is not able to identify any unjustified deviations from the PCR and EN 15804+A2 in the Environmental Product Declaration and its project report.

EPD Hub maintains its independence as a third-party body; it was not involved in the execution of the LCA or in the development of the declaration and has no conflicts of interest regarding this verification.

The company-specific data and upstream and downstream data have been examined as regards plausibility and consistency. The publisher is responsible for ensuring the factual integrity and legal compliance of this declaration.

The software used in creation of this LCA and EPD is verified by EPD Hub to conform to the procedural and methodological requirements outlined in ISO 14025:2010, ISO 14040/14044, EN 15804+A2, and EPD Hub Core Product Category Rules and General Program Instructions.

### [Verified tools](#)

Tool verifier: Magaly Gonzalez Vazquez

Tool verification validity: 27 March 2025 - 26 March 2028

Haiha Nguyen as an authorized verifier for EPD Hub Limited 18.05.2026

